

POWERING MOBILE NETWORKS WITH GREEN ENERGY

TAO HAN AND NIRWAN ANSARI, NEW JERSEY INSTITUTE OF TECHNOLOGY

ABSTRACT

Explosive mobile data demands are driving a significant growth in energy consumption in mobile networks, and consequently a surge of carbon footprints. Reducing carbon footprints is crucial in alleviating the direct impact of greenhouse gases on the earth environment and the climate change. With advances of green energy technologies, future mobile networks are expected to be powered by green energy to reduce their carbon footprints. This article provides an overview on the design and optimization of green energy enabled mobile networks, discusses the energy models for the analysis and optimization of the networks, and lays out basic design principles and research challenges on optimizing the green energy powered mobile networks.

INTRODUCTION

Mobile networks are among the major energy guzzlers of the information communications technology (ICT) infrastructure, and their contributions to the global energy consumption accelerate rapidly because of the dramatic mobile data traffic surges [1]. The growing energy consumption not only escalates the operators' operational expenditures (OPEX) but also leads to a significant rise of carbon footprints. Therefore, greening mobile networks is becoming a necessity to bolster social, environmental, and economic sustainability.

Owing to the direct impact of greenhouse gases on the earth environment and the climate change, there has been a consensus on limiting per-nation CO_2 emissions according to the Kyoto protocol.¹ As a result, governments are likely to regulate CO_2 emissions of individual industries in their countries. In this circumstance, mobile network operators may be given a total per-month or per-year energy budgets in the term of CO_2 emissions. Therefore, the mobile network operators are driven to reduce their energy consumption.

As the smart grid develops, the penetration of distributed electricity generation is galvanizing worldwide. Distributed electricity generators which capitalize on green energy sources, e.g., solar energy and wind energy, can substantially reduce carbon footprints. Taking advantages of

distributed electricity generators, telecommunications equipment manufacturers, such as Nokia Siemens and Ericsson, have designed and built green energy powered off-grid base stations (BSs) to reduce the OPEX of mobile networks in rural areas. However, at the current stage, green energy is more expensive than grid energy in term of the cost per watt. Thus, green energy enabled BSs are not deployed at a large scale.

Continuous advances in green energy technologies are improving the efficiency of generating electricity using renewable sources, and are at the same time driving down the cost of deploying a green power system. For example, the efficiency of photovoltaic (PV) solar panel is predicted to be tripled by 2030, and the cost of per watt generated by the PV solar panel is anticipated to be at least halved as compared to the current cost according to the technology roadmap for solar photovoltaic energy.² Therefore, green energy will be a promising energy alternative for future mobile networks. Piro *et al.* [2] evaluated the CO_2 emission savings and the cost of green power systems for various network scenarios and showed that properly powering a heterogeneous network with green energy can be a sustainable and economically friendly solution. Hassan *et al.* [3] further classified the scenarios and the objectives on utilizing renewable energy in mobile networks.

It is, however, not trivial to design and optimize the green energy enabled mobile networks. As shown in Fig. 1, in addition to radio resource management, optimizing green energy enabled mobile networks involves the optimization of the utilization of green energy from both standalone power generators and green power farms. Meanwhile, smart grid techniques enable the power trading among the consumers via smart meters. As a result, power cooperation, which enables BSs share their green power with each other, has been introduced to engineer green energy enabled mobile networks. The coupling of the radio resource optimization and the power utilization optimization introduces new research challenges on optimizing green energy enabled mobile networks. In this article, we investigate the design and optimization issues involved in green energy enabled mobile networks. We first briefly discuss the green power generation and prediction models, and the mobile network ener-

This work was supported in part by NSF under grant no. CNS-1218181 and no. CNS-1320468.

¹ The Kyoto protocol to the United Nations framework convention on climate change is available at <http://unfccc.int/resource/docs/convkp/kpeng.pdf>.

² Technology roadmap for solar photovoltaic energy is available at http://www.iea.org/publications/freepublications/publication/pv_roadmap.pdf.

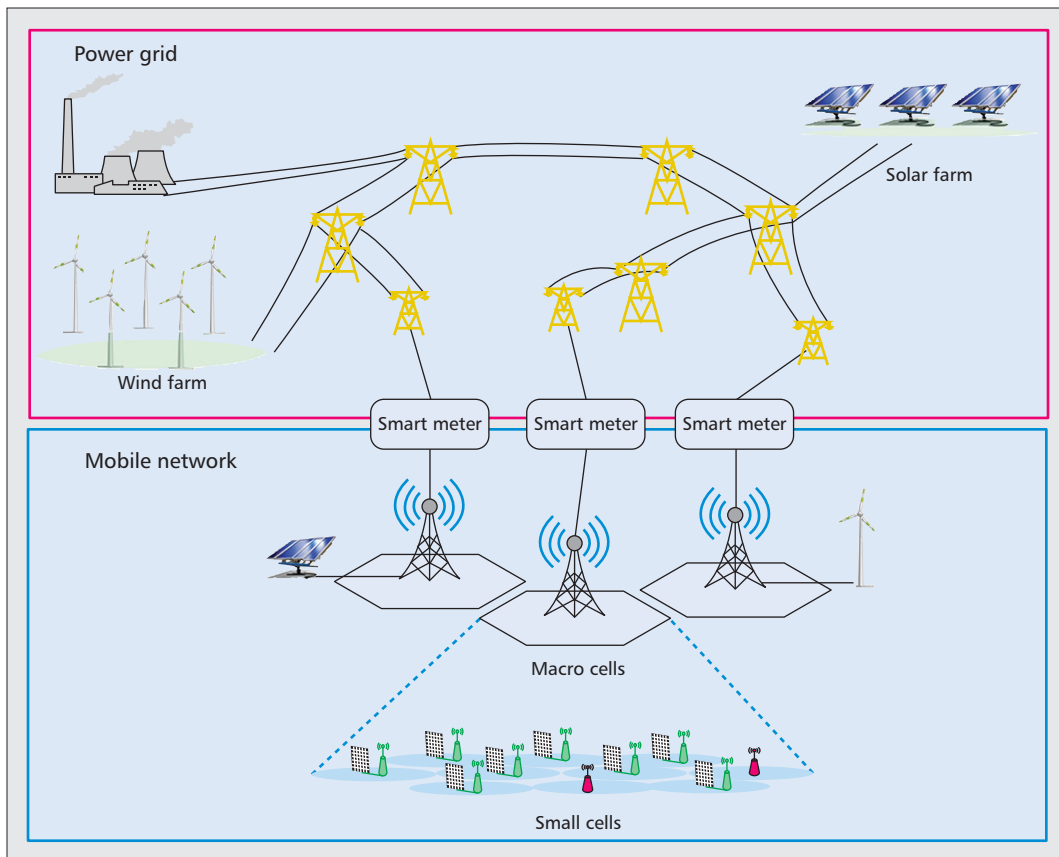

Figure 1. Green energy enabled mobile networks.

Since green power generation is highly dynamic, a green energy powered system should be designed and optimized to incorporate the dynamics of the power generation. For system implementations, the availability of green energy is predicted based on statistical data using various prediction models

gy consumption models. Then, we investigate how to design and optimize the green energy powered BSs including provisioning the green energy system and optimizing resource management in BSs. In addition, we provide a discussion on how to optimize green energy enabled mobile networks under different network power supply scenarios. This article provides a timely overview of the research challenges and existing solutions for green energy enabled mobile networks and paves the way for powering mobile networks with green energy.

GREEN ENERGY MODELS: GENERATION AND CONSUMPTION

The green power generation, which highly depends on the power generators' geo-locations and weather conditions, is rather dynamic. Meanwhile, the energy consumption of mobile networks is also highly dynamic. Thus, understanding the characteristics of green power generations and the dynamics of the energy consumption of mobile networks are essential for designing and optimizing green energy enabled mobile networks.

GREEN POWER GENERATION

Since green power generation is highly dynamic, a green energy powered system should be designed and optimized to incorporate the dynamics of the power generation. For system implementations, the availability of green energy

is predicted based on statistical data using various prediction models [4]. For example, the availability of solar energy is predicted based on the statistical data that provide the solar energy expected under a clear sky condition, and the cloud coverage estimation that forecasts the percentage of the sky is covered by the cloud. Denote E , E_c , and β as the amount of predicted solar energy, the amount of solar energy under a clear sky condition, and the cloud coverage estimation, respectively. Then, $E = E_c(1 - \beta)$. For theoretical analysis, the energy harvest process is modeled as a stochastic process. The first order Markov stochastic process is an analytically simple and practically accurate model for solar energy generation [5].

MOBILE NETWORK ENERGY CONSUMPTION

BSs, which consist of multiple components such as antennas, power amplifiers, radio frequency transceivers, baseband processing units, power supply units, and cooling units, account for the major energy consumption of a mobile network. In general, a BS's power consumption can be modeled as the sum of its static power consumption and its dynamic power consumption. The static power consumption is the power consumption of a BS without any traffic load. The dynamic power consumption refers to the additional power consumption caused by traffic load in the BS, which can be well approximated by a linear function of the traffic load or the output radio frequency power [6]. The BS power consumption model can be adjusted to model the power con-

³ *LOLP is defined as the probability of not being able to satisfy the energy demands while LOEP measures the amount of energy loss due to the inability to charging the battery beyond its maximum capacity.*

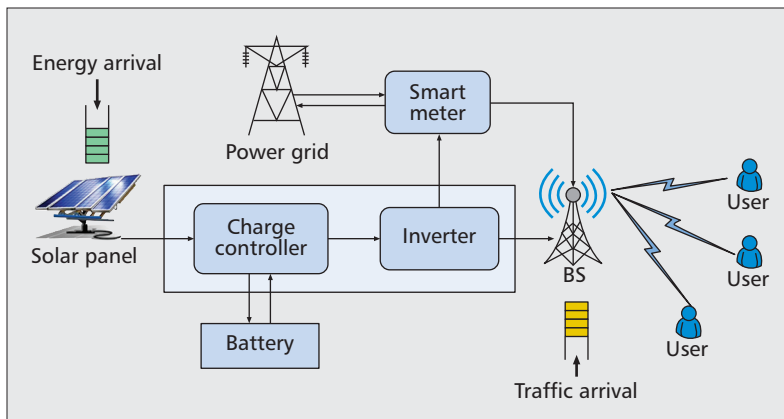

Figure 2. A green energy powered BS.

sumption of either macro BSs or small cell BSs by incorporating and tweaking the BS's static power consumption and the linear coefficient that reflects the relationship between the BS's dynamic power consumption and its traffic load.

OPTIMIZING THE GREEN ENERGY POWERED BS

In order to maximize the green power utilization, green energy powered BSs should be properly designed and optimized to cope with the dynamics of green power and mobile data traffic. Figure 2 shows a simplified diagram of a green energy powered BS. In order to utilize green energy, five energy related components may be integrated into a BS. These components are the green power generator, e.g., solar panel, the charge controller which regulates the output voltage of the green power generator, the DC-AC inverter, the battery, and the smart meter which enables the power transmission between BSs and the power grid.

GREEN ENERGY PROVISIONING

By integrating green energy into mobile networks, mobile service providers may save on-grid power consumption and thus reduce their CO_2 emissions. However, equipping a BS with a green energy system incurs additional capital expenditures (CAPEX) which are determined by the size of the green power generator, the battery capacity, and other installation expenses. It is desired to minimize the CAPEX on provisioning green energy for BSs. Here, the green energy provisioning is referred to as determining the maximum capacity of the green power generator and the battery. Although the green energy provisioning problem for off-grid loads are well studied [7], the existing solutions do not directly apply to provisioning green energy for mobile networks. The process of green energy provisioning involves three basic models: the load model, the battery model, and the green power generation model. The existing solutions usually take the statistical load information as an input and evaluate the loss of load probability (LOLP) and the loss of energy probability (LOEP).³ Based on the evaluation results, these methods adjust the green power generator sizes and bat-

⁴ The power grid dynamics refers to the dynamics of the power generation and power demand in the power grid.

tery capacity until the system performance in terms of LOLP and LOEP is satisfied. These methods relying only on the statistical load information do not optimize the energy utilization, and may result in over provisioning.

In a mobile network, a BS's power consumption can be adapted according to the availability of green energy. On the one hand, a BS's transmission strategies can be optimized to reduce the energy demands without degrading the quality of service of the network [5]. On the other hand, owing to seamless deployment of BSs, a mobile user may be covered by multiple BSs. The traffic load of a BS can be reduced by offloading its associated users to neighboring BSs. In this way, the BS's power consumption is adapted. Therefore, by optimizing the BS's transmission strategies and mobile network layout, the power consumption of the BSs can be optimized to minimize the size of the green energy system.

THE BS'S RESOURCE MANAGEMENT

Since renewable energy is highly dynamic, the green power may not be able to always guarantee sufficient power supplies to BSs even though the green power system is well provisioned. Therefore, the BS's resource management including energy management and radio resource management should be optimized in order to optimize the BS's performance with constrained green energy.

A BS's optimal resource management depends on five dynamic processes: the energy arrival dynamics, the battery dynamics, the power grid dynamics,⁴ the traffic dynamics and the wireless channel condition dynamics. Owing to the complex coupling of the energy allocation and radio resource allocation, it is challenging to achieve optimal resource management.

Packet Scheduling Optimization — While it is mathematically intractable to obtain optimal packet scheduling with consideration of all of these dynamic processes, several contributions have provided some insights on solving this difficult problem. Considering a single user communication system with energy harvest transmitter, Yang and Ulukus [8] proposed to optimize the packet transmission policy to minimize the packet transmission completion time. For this problem, the most challenging aspect is the causality constraint: a packet cannot be delivered before it has arrived and the energy cannot be consumed before it is harvested. This constraint introduces a tradeoff between the energy harvest time and the packet transmission time in determining the transmission rate and power. In general, considering a network with a single transmitter, using more transmission power may enable a higher transmission rate and thus reduces the packet transmission time. However, since the causality constraint is introduced by green energy, in order to adopt a higher transmission rate, the transmitter has to wait until enough green energy is harvested.

For a multi-user system, the multi-user diversity in terms of channel conditions can be explored to enhance the green energy utilization. Within a given completion time, transmitting a

packet toward a user with better channel condition usually requires less transmit power. Therefore, scheduling different users at a given time slot may require different amounts of green energy. By exploring the multi-user diversity, a packet scheduling algorithm may shape the BS's energy demands to match the green power generation [9]. If a BS's energy demands perfectly match the green power generation, no additional energy sources are required to sustain the traffic demands in the BS.

Energy Allocation Optimization — Since mobile traffic shows temporal dynamics, a BS's energy demands change over time.

The green power generation varies along the time horizon. Thus, in order to optimize their performance, BSs should determine how much energy is utilized at the current stage and how much energy is reserved for the future. If more energy is utilized at the current stage, the BS may provision a larger capacity. However, the BS may suffer from the service outage due to energy shortages in future stages. In order to satisfy the network's outage constraint, Farbod and Todd [10] proposed to reduce the BS's power consumption at certain stages by reducing the BS's instantaneous capacity to alleviate the service outages. The proposed on/off proportional capacity deficit algorithm satisfies the outage constraint with the minimum capacity deficit.

OPTIMIZING THE GREEN ENERGY ENABLED MOBILE NETWORKS

Green energy enabled mobile networks may consist of BSs with different power supply configurations, as classified in Fig. 3. Based on whether a BS is connected to the power grid, the BS is classified as an on-grid BS or an off-grid BS. The power supplies for an on-grid BS can be grid power and green power from either the standalone green power generator or from the green power farm, e.g., a solar/wind farm. An off-grid BS may be powered by regular power (non-renewable energy such as diesel) and green power from either individual generator or green power farm. Considering BSs' various power sources, optimizing green energy enabled mobile networks is challenging. In this section, we discuss the network optimization for off-grid green mobile network, on-grid green mobile network, and mobile network consisting of both green BSs and grid powered BSs.

OFF-GRID GREEN MOBILE NETWORKS

Powered by Standalone Green Power Generator — When a BS is powered by a standalone green power generator, the green power generated in the BS is not shared with other BSs. Under this scenario, the fundamental design issue is how to utilize the harvested energy to sustain traffic demands of users in the network. The optimal utilization of green energy over a period of time depends on the characteristics of the energy arrival and power consumption at the current time slots as well as in future time slots. Optimizing green energy utilization involves two aspects. The first aspect is to optimize the energy allocation in mul-

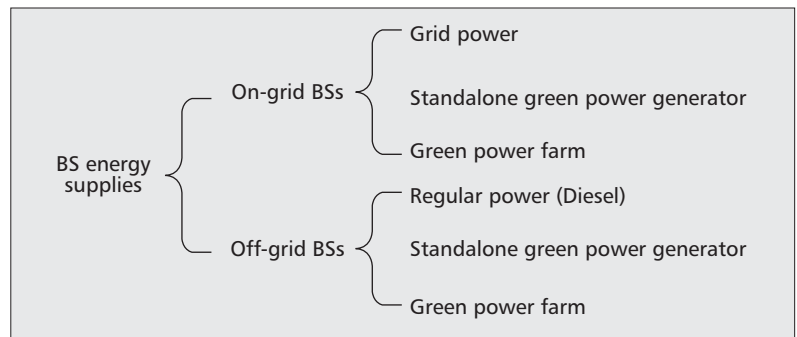

Figure 3. A BS's power supplies.

multiple time slots by determining how much energy should be used at the current time slot, and how much energy is reserved for future time slots for individual BSs. To solve the energy allocation problem, parameters such as the current energy arrival and consumption and the estimations of future energy arrival and consumption should be considered. The second aspect is to maximize the utilization of the allocated green energy at individual time slots. The BSs' power consumption depends on the intensity of the mobile traffic which exhibits spatial diversities.⁵ Thus, the power consumption in BSs may be different. In order to sustain traffic demand of all users, the green energy utilization should be optimized by balancing the power consumption among BSs according to the availability of green energy. The power consumption of BSs is balanced by balancing the traffic loads among the BSs [11].

Powered by Green Power Farm — When BSs in the mobile network are powered by green power farms, the total amount of green energy is budgeted by the capacity of the green power farms. Given a total power constraint, the network performance can be improved by optimizing the spatial and temporal power sharing [12]. Since mobile traffic exhibits spatial diversities, the mobile user distributions in different BSs are usually different. Thus, the mobile users in different BSs may experience different signal-interference-noise ratios (SINRs). In order to save energy, the BSs whose mobile users have better SINR may reduce their transmit power. Since the achievable data rates for users with high SINR logarithmically decreases as the SINR decreases, reducing the BSs' transmit power will not significantly impair the users' achievable data rates. In addition, reducing the BSs' transmit power may increase the SINR of their neighboring BSs' cell edge users. As a result, the neighboring BSs may also reduce their transmit power to save energy. Therefore, the budgeted green energy should be properly shared across the BSs. On the other hand, since mobile users' channel conditions vary over time, scheduling a user in different time slots results in different power consumption in a BS. For example, if a user experiences severe channel conditions, in order to save energy, the BS may not schedule the user until its channel condition is satisfactory. Thus, for individual BSs, the power consumption in different time slots should be optimized via user scheduling.

⁵ The spatial diversity of mobile traffic implies that BSs in different locations experience different traffic demands.

In a mobile network with BSs powered by both on-grid power and green power, a green energy and latency aware user association scheme is preferred to achieve a balance between the green power utilization and the network latency.

ON-GRID GREEN MOBILE NETWORKS

On-grid Green Mobile Networks refer to as the mobile networks whose BSs are not only connected to power grid but also equipped with standalone green power generators. Green power is utilized to reduce the on-grid power consumption while grid power is a backup power source to compensate for the power demand which exceeds the green power capacity.

For on-grid green mobile networks, the energy storage (the battery) is not necessarily located in individual BSs' green energy systems because the BSs are connected to power grid for the energy backup. Thus, the optimal green energy utilization strategy is different depending on whether BSs have energy storage. On the one hand, when the BSs have energy storage, green energy can be stored and utilized to shift the peak power demands, thus reducing the OPEX as well as alleviating the CO_2 emissions. For example, as the smart grid advances, the electricity price is highly correlated to the demands. In the peak power demand hours, the electricity price is usually higher than that in off-peak power demand hours. In this case, in order to reduce the OPEX, green energy is utilized when the electricity price is higher than a threshold, and is stored in the batteries when the electricity price is low.

On the other hand, when the BSs do not have energy storage, green energy should be utilized when it is generated. In this case, in order to maximize the green energy utilization, traffic loads are directed to the BSs with larger green power generation capacity. In other words, the BSs with larger green energy capacity serve more traffic loads while the BSs with smaller green energy capacity serve less traffic load.

Green Energy Aware User Association — Green energy aware user association is to direct the traffic loads to the BSs with higher green energy capacity. However, such user association strategies may result in traffic congestion in BSs with larger green energy capacity. Therefore, a proper traffic offloading scheme is desirable not only to optimize the utilization of green energy but also to avoid excessive traffic congestion in BSs. Han and Ansari [13] proposed a green energy aware and latency aware (GALA) user association scheme which minimizes the sum of the weighted traffic delivery latency of BSs in a heterogeneous mobile network. The weight of a BS reflects the green power capacity of the BS. A large weight indicates a small green power capacity in a BS.

We evaluate the performance of the latency aware (LA), the green energy aware (GEA), and the GALA user association schemes using a similar simulation setting as in [13]. The latency aware user association is achieved by applying the distributed α -optimal user association algorithm implemented with the latency minimization policy [14]. In the energy aware scheme, the user association scheme is determined to minimize the overall on-grid power consumption. The simulated network topology is shown in Fig. 4a where the green stars and the red squares represent the macro and the micro BSs, respec-

tively. The transmit power of the macro and micro BS are 43 dBm and 21 dBm, respectively. We adopt COST 231 Walfisch-Ikegami as the propagation model.

In Fig. 4b, we can see that after these algorithms converge, the GEA scheme minimizes the on-grid power of the mobile network. As compared to the GEA scheme, the GALA scheme consumes additional 33 percent on-grid power. The LA scheme consumes 13 percent more on-grid power than the GALA scheme does. However, as shown in Fig. 4c, the GEA scheme significantly increases the network latency: as compared to the GALA scheme, the GEA takes 35 percent more time to deliver the same amount of traffic. The LA scheme minimizes the network latency at the expense of more on-grid power consumption. As compared with the LA scheme, the GALA scheme only increase 1 percent network latency but consumes 13 percent less on-grid power. Thus, the GALA scheme achieves a better tradeoff between on-grid power consumption and the network latency. Therefore, in a mobile network with BSs powered by both on-grid power and green power, a green energy and latency aware user association scheme is preferred to achieve a balance between the green power utilization and the network latency.

Green Energy Aware BS Sleeping — Traffic demands in mobile networks show highly temporal dynamics, thus requiring large capacity in peak usage hours but reduced requirements during off-peak hours [1]. Mobile networks are usually dimensioned for peak hour traffic, and thus most of BSs operate at low work load during the off-peak hours. Owing to the large static power consumption, these BSs have poor energy efficiency. In this case, optimally turning some of these BSs into the sleeping mode will enhance the energy efficiency of mobile networks while maintaining sufficient network capacity. When BSs in the mobile network are powered by green power generated from their standalone power generators, the optimal BS sleeping strategies should take green power into account. If a BS's green power cannot be shared with other BSs or be stored, the BS should keep alive as long as it has sufficient green power to sustain its operation even though the BS has low traffic loads. However, if the BS's green power can be shared among other BSs via smart grid, the power transmission efficiency of the power grid also determines whether the BS should sleep or not. When the power transmission efficiency of the power grid is high, the green power can be losslessly transferred among BSs. Thus, the optimal BS sleeping strategies are similar to that applied in mobile networks without green power supplies. When the power transmission loss is considerable, the tradeoff between the power transmission loss and BSs' static power consumption should be examined in determining the optimal BS sleeping strategies.

Green Energy Aware CoMP — The coordinated multi-point (CoMP) transmission is a promising technique that enhances the network efficiency and overall user quality of services for next gen-

⁶ Each BS may be equipped with multiple transmit antennas and each transmit antenna can be recognized as a transmit point.

eration mobile networks. By applying CoMP, multiple BSs either jointly transmit data to mobile users or coordinately schedule their data transmissions. There are two basic design issues in optimizing CoMP. The first one is the cluster formation (CF) problem which determines which transmit points⁶ should be clustered to perform CoMP transmission. The other issue is the resource allocation (RA) problem which optimizes the spectrum and power allocation among multiple transmit points within a cluster. In on-grid green mobile networks, different BSs may have different amount of green power. Thus, the available green power for the transmit points is different. If the power consumption of a transmit point is larger than the available amount of green power, the transmit point consumes on-grid power. Given the green power in each BS, optimizing CoMP to minimize the on-grid power consumption involves both the CF and RA problem. Considering the green power constraint in individual BSs, the CF and RA problems are highly coupled. On the one hand, if the cluster formation is given, the optimal power allocation that minimizes the on-grid power consumption while satisfying the users' quality of service requirements can be derived. On the other hand, if the power allocation is given, the optimal cluster formation can be obtained. Thus, the optimal power allocation depends on the cluster formation, and vice versa. Owing to the coupling of the CF and RA problems, it is challenging to solve the CoMP transmission problem.

MIXTURE OF GREEN BSs AND GRID POWERED BSs

We define a green BS as the BS having green power supplies from either standalone green power generators or green power farms. A grid powered BS is defined as the BS without any green power supply. When mobile networks consist of both green BSs and grid powered BSs, the mobile network optimization is to minimize the on-grid power consumption and maximize the utilization of green energy. Therefore, the mobile network is to guide more data traffic to the green BSs. Two approaches have been proposed to encourage mobile users to access the BSs powered by green energy. The first approach is to adjust the handover parameters to prioritize the green BSs [15]. This approach adjusts the handover parameters of BSs to enable mobile users more easily to handover to BSs powered by green energy than to those powered by grid energy. The other approach [15] is to increase the transmit power of the BSs powered by green energy, thus enlarging the coverage area of these BSs. As a result, more mobile traffic will be offloaded to the BSs powered by green energy.

CONCLUSION

This article discusses the design and optimization of green energy enabled mobile networks. We have briefly discussed the green power generation and the mobile network power consumption models. We have also investigated how to design and optimize green energy powered BSs

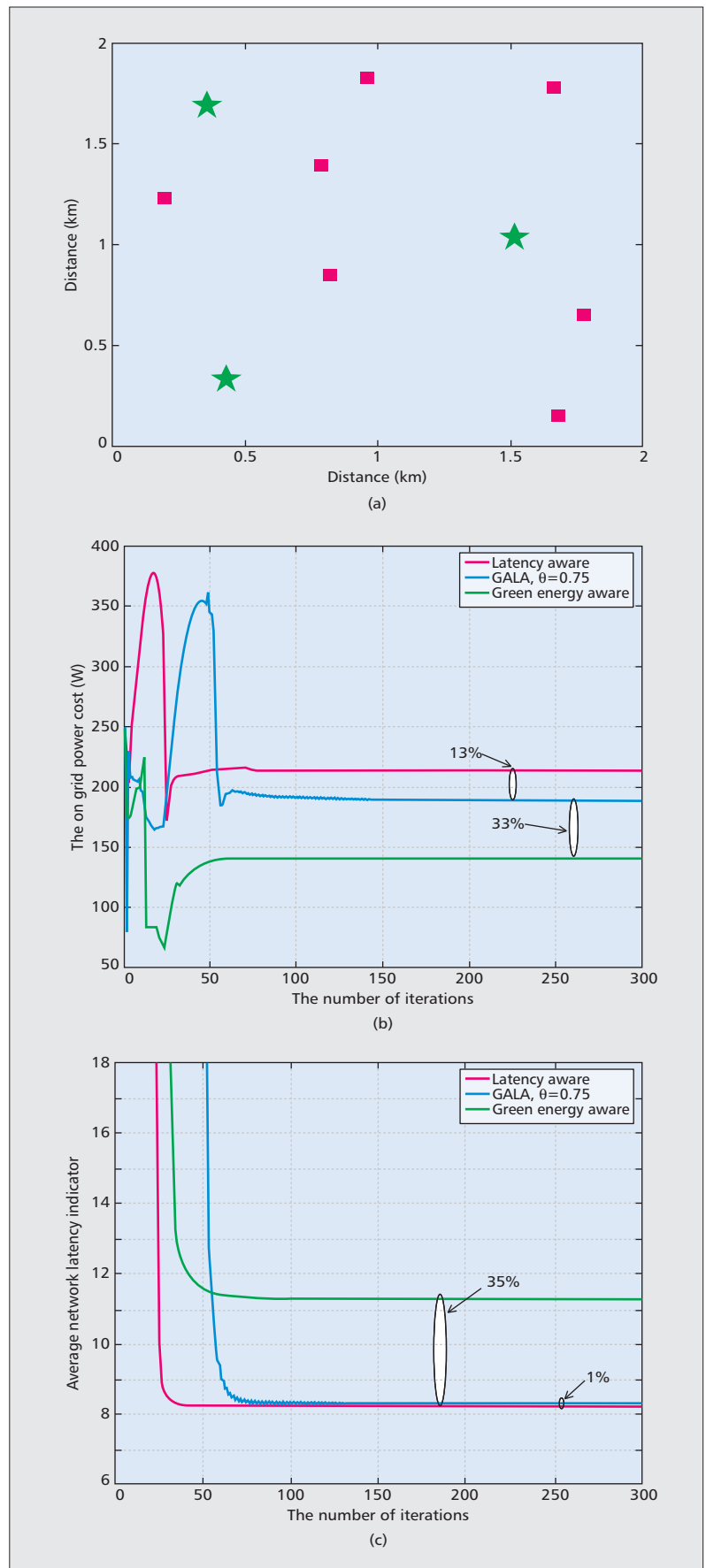

Figure 4. Performance comparison of different traffic balancing schemes: a) the network topology; b) the on-grid power consumption; and c) the average traffic delivery latency.

by provisioning the green power system and optimizing the BS's resource management. In addition, we have analyzed network design and optimization issues for green energy enabled mobile networks under different network power supply configurations. In future mobile networks, BSs may be powered by various energy sources. The joint optimization of the radio resource utilization and the energy utilization for green energy enabled mobile networks are challenging and will be investigated in our future works.

REFERENCES

- [1] T. Han and N. Ansari, "On Greening Cellular Networks via Multicell Cooperation," *IEEE Wireless Commun.*, vol. 20, no. 1, Feb. 2013, pp. 82–89.
- [2] G. Piro, et al., "Hetnets Powered by Renewable Energy sources: Sustainable Next-Generation Cellular Networks," *IEEE Internet Computing*, vol. 17, no. 1, 2013, pp. 32–39.
- [3] H. A. H. Hassan, L. Nuaymi, and A. Pelov, "Classification of Renewable Energy Scenarios and Objectives for Cellular Networks," *Proc. IEEE PIMRC '13*, London, U.K., Sept. 2013.
- [4] I. N. Goiri et al., "Greenhadoop: Leveraging Green Energy in Data-Processing Frameworks," *Proc. ACM EuroSys '12*, Bern, Switzerland, 2012, pp. 57–70.
- [5] C. K. Ho and R. Zhang, "Optimal Energy Allocation for Wireless Communications with Energy Harvesting Constraints," *IEEE Trans. Signal Processing*, vol. 60, no. 9, 2012, pp. 4808–18.
- [6] G. Auer et al., "How Much Energy Is Needed to Run a Wireless Network?" *IEEE Wireless Commun.*, vol. 18, no. 5, pp. 40–49, Oct. 2011.
- [7] H. A. M. Maghraby, M. Shwehdi, and G. Al-Bassam, "Probabilistic Assessment of Photovoltaic (PV) Generation Systems," *IEEE Trans. Power Systems*, vol. 17, no. 1, Feb. 2002, pp. 205–8.
- [8] J. Yang and S. Ulukus, "Optimal Packet Scheduling in an Energy Harvesting Communication System," *IEEE Trans. Commun.*, vol. 60, no. 1, 2012, pp. 220–30.
- [9] T. Han and N. Ansari, "Energy Agile Packet Scheduling to Leverage Green Energy for Next Generation Cellular Networks," *Proc. IEEE ICC '13*, Budapest, Hungary, June 2013, pp. 3650–54.
- [10] A. Farbod and T. D. Todd, "Resource Allocation and Outage Control for Solar-Powered WLAN Mesh Networks," *IEEE Trans. Mobile Computing*, vol. 6, no. 8, Aug. 2007, pp. 960–70.
- [11] T. Han and N. Ansari, "ICE: Intelligent Cell Breathing to Optimize the Utilization of Green Energy," *IEEE Commun. Letters*, vol. 16, no. 6, June 2012, pp. 866–69.
- [12] J. Kwak et al., "Greening Effect of Spatio-Temporal Power Sharing Policies in Cellular Networks with Energy Constraints," *IEEE Trans. Wireless Commun.*, vol. 11, no. 12, Dec. 2012, pp. 4405–15.
- [13] T. Han and N. Ansari, "Green-Energy Aware and Latency Aware User Associations in Heterogeneous Cellular Networks," *Proc. IEEE GLOBECOM '13*, Atlanta, GA, Dec. 2013.
- [14] H. Kim et al., "Distributed–Optimal User Association and Cell Load Balancing in Wireless Networks," *IEEE/ACM Trans. Networking*, vol. 20, no. 1, Feb. 2012, pp. 177–90.
- [15] J. Zhou, M. Li, L. Liu, X. She, and L. Chen, "Energy Source Aware Target Cell Selection and Coverage Optimization for Power Saving in Cellular Networks," *Proc. IEEE/ACM GreenCom '10*, Hangzhou, China, Dec. 2010, pp. 1–8.

BIOGRAPHIES

TAO HAN [S'08] (th36@njit.edu) received B.E. in Electrical Engineering and M.E. in Computer Engineering from Dalian University of Technology and Beijing University of Posts and Telecommunications, respectively. He is currently a Ph.D. candidate in the Department of Electrical and Computer Engineering, New Jersey Institute of Technology, Newark, New Jersey. His research interests include wireless communications, mobile and cellular networking, network optimization, and green communications.

NIRWAN ANSARI [S'78, M'83, SM'94, F'09] (nirwan.ansari@njit.edu) received BSEE (summa cum laude with a perfect GPA) from NJIT, MSEE from the University of Michigan, Ann Arbor, and Ph.D. from Purdue University, West Lafayette, IN. He joined NJIT in 1988, where he is Professor of Electrical and Computer Engineering. He has also assumed various administrative positions at NJIT. He was Visiting (Chair/Honorary) Professor at several universities. His current research focuses on various aspects of broadband networks and multimedia communications. He has served on the Editorial/Advisory Board of nine journals. He was elected to serve in the IEEE Communications Society (ComSoc) Board of Governors as a member-at-large (2013–2015). He has chaired ComSoc technical committees, and has been actively organizing numerous IEEE International Conferences/Symposia/Workshops, assuming leadership roles as Chair or TPC Chair of various Conferences, Symposia and Workshops. He has authored *Computational Intelligence for Optimization* (Springer 1997) with E.S.H. Hou, *Media Access Control and Resource Allocation for Next Generation Passive Optical Networks* (Springer, 2013) with J. Zhang, and edited *Neural Networks in Telecommunications* (Springer 1994) with B. Yuhas. He has also contributed over 450 publications, over one third of which were published in widely cited refereed journals/magazines. He has been granted over twenty U.S. patents. He has also guest-edited a number of special issues, covering various emerging topics in communications and networking. He has been frequently selected to deliver keynote addresses, distinguished lectures, and tutorials. Some of his recent recognitions include a couple of *best paper* awards, several Excellence in Teaching Awards, Thomas Alva Edison Patent Award (2010), NJ Inventors Hall of Fame Inventor of the Year Award (2012), and designation as a ComSoc Distinguished Lecturer (2006–2009).