

The exam is closed book and closed notes. A one-page equation sheet is allowed.

“On my honor, I pledge that I have not violated the provisions of the NJIT Student Honor Code.” Signature Solutions

Print Name _____ Section _____

Part I: There are 10 multiple choice Questions.

Make sure you put your name, section, and ID number on the SCANTRON form. . **Failure to do so will cost you two points.** The answers for the multiple choice Questions are to be placed on the SCANTRON form provided. Use a Number 2 pencil to fill in answers on the SCANTRON form. Make sure you give only one (1) answer to each question. **If you erase an answer on the SCANTRON form, make sure all traces are removed.**

Parts II : Workout problems. Show ALL your work. Correct answers with unsubstantiated work will receive **ZERO CREDIT.**

Part I (30 points)

1. A toy box rests on top of a (heavier) dog house, which sits on a wood floor. Which set of vector(s) best represents a free body diagram of the dog house?

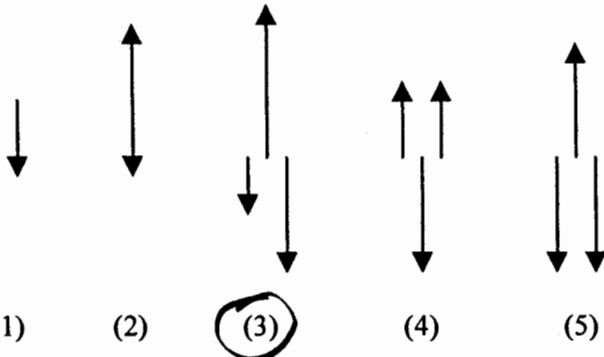

(1)

(2)

(3)

(4)

(5)

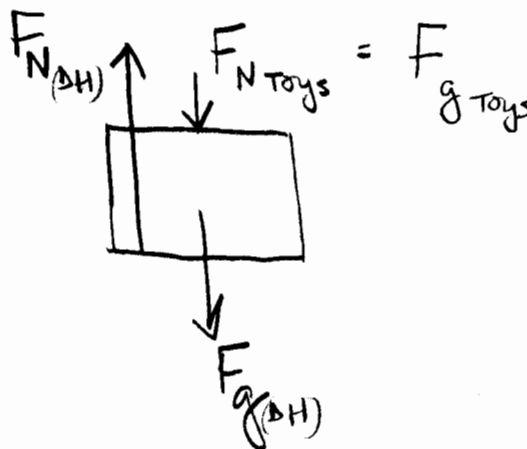

- A) 1
- B) 2
- C) 3
- D) 4
- E) 5

Two blocks are connected by a string that passes over a frictionless pulley. If $M=3.0$ kg and $m=2.0$ kg, the acceleration of the blocks is

- A) 2.0 m/s^2
- B) 3.9 m/s^2**
- C) 5.0 m/s^2
- D) 9.8 m/s^2
- E) 19.6 m/s^2

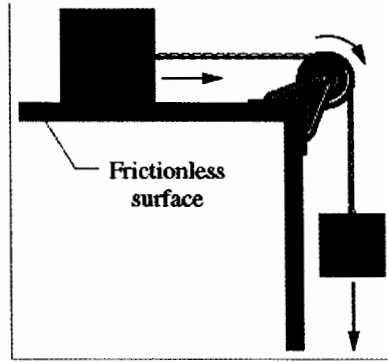
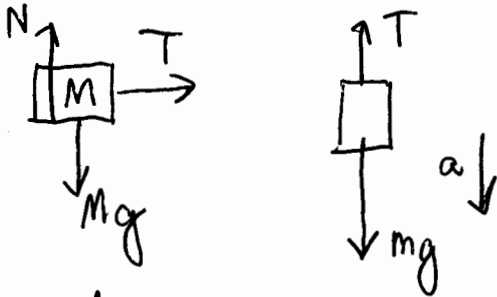

$T = Ma$
 $T - mg = -ma$
 $Ma + ma = mg$
 $a = \frac{mg}{M+m} = 3.9 \text{ m/s}^2$

3. If the string were to break as mass M moves toward the pulley, the speed of mass m would then

- A) remain constant
- B) decrease
- C) increase at a rate of 9.8 m/s^2**
- D) be equivalent to zero
- E) increase at a rate greater than 9.8 m/s^2

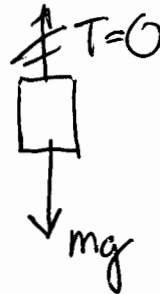

$F_{\text{net},y} = ma_y$
 $-mg = -ma_y$
 $g = a_y$

4. In earlier days, horses pulled barges down canals as shown in the figure. Suppose that the horse pulls on the rope with a force of 7900 N , at an angle of 18° to the direction of motion. Assuming the barge has a mass of 9500 kg and is headed straight along the canal with an acceleration of 0.12 m/s^2 , what is the magnitude of the other force (from the water) acting on the barge?

- A) 1140 N
- B) 2441 N
- C) 7513 N
- D) 6373 N
- E) 6824 N**

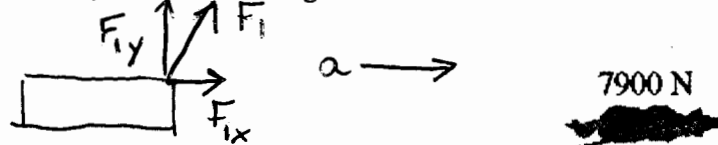

$\vec{F}_{\text{net}} = m\vec{a}$
 $\vec{F}_1 + \vec{F}_2 = m\vec{a}$

$F_{\text{net},x} = ma_x$

$F_{\text{net},y} = ma_y$

Since a is in x direction
 F_{net} should be " "

$F_{2x} = ma_x$

$F_{1y} + F_{2y} = m(a_y) = 0$

$F_2 = \sqrt{F_{2x}^2 + F_{2y}^2}$
 $= 6824 \text{ N}$

$F_2 = ma_x - F_{1x}$

$F_{2y} = -F_{1y}$

$= 9500 \text{ kg} (0.12 \text{ m/s}^2) - 7900 \text{ N} \cos 18^\circ$
 $= -6373 \text{ N}$

$F_{2y} = -7900 \text{ N} \sin 18^\circ$
 $= -2441 \text{ N}$

5. Two blocks, $m_1 = 4.0$ kg and $m_2 = 8.0$ kg, on a frictionless table are pushed by a horizontal force $F = 30$ N, as shown below:



If the blocks accelerate at 2.5 m/s², the force exerted by m_1 on m_2 must be

- A) 30 N
 B) 20 N
 C) 15 N
 D) 10 N
 E) 0 N

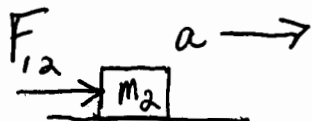

$$F_{12} = m_2 a$$

$$= (8.0 \text{ kg})(2.5 \text{ m/s}^2)$$

$$= 20 \text{ N}$$

6. Two identical blocks — i.e. both blocks have the same mass, geometry, and the material of construction — are pulled along a rough surface as suggested in the figure. All the surfaces of the blocks have the same level of roughness. Which one of the following statements is false?

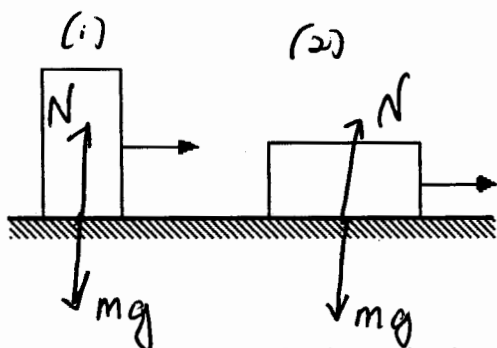

$$F_{S, \text{max}} = \mu_s N \quad \mu_{s1} = \mu_{s2} \quad N_1 = N_2 \quad F_{S, \text{max}1} = F_{S, \text{max}2}$$

$$F_k = \mu_k N$$

$$\mu_{k1} = \mu_{k2} \quad N_1 = N_2$$

$$F_{k1} = F_{k2}$$

- A) The coefficient of kinetic friction is the same in each case.
 B) A force of the same magnitude is needed to keep each block moving.
 C) A force of the same magnitude was required to start each block moving.
 D) The magnitude of the force of kinetic friction is greater for the block on the right.
 E) The normal force exerted on the blocks by the surface is the same for both blocks.

7. A 50.0-kg box is being pushed along a horizontal surface. The coefficient of kinetic friction between the box and the ground is 0.350. What horizontal force must be exerted on the box for it to accelerate at 1.20 m/s²?

- A) 60.0 N
 B) 172 N
 C) 232 N
 D) 491 N

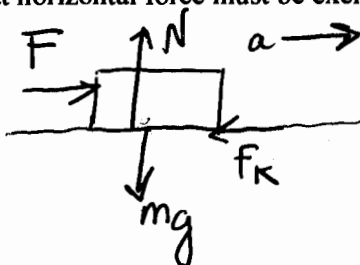

$$F - f_k = ma \quad N - mg = 0$$

$$F = f_k + ma$$

$$F = \mu_k N + ma$$

$$F = \mu_k mg + ma = 232 \text{ N}$$

A box rests on a rough board 10.0 meters long. When one end of the board is slowly raised to a height of 6.00 meters above the other end, the box begins to slide. The coefficient of static friction is:

- A) 0.8
- B) 0.25
- C) 0.4
- D) 0.6
- E) 0.75**

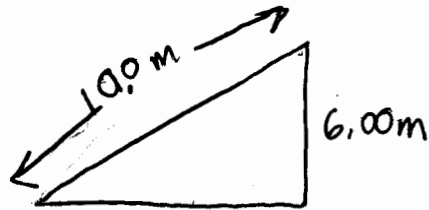

$$\mu_s = \tan \theta \quad \theta = \sin^{-1} \left(\frac{6.00}{10.0} \right)$$

$$\mu_s = \tan 37^\circ = 0.75$$

Derivation:

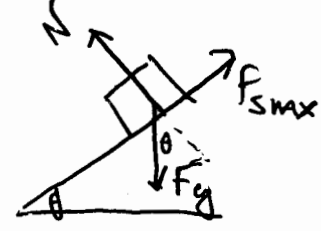

$$f_{smax} - F_{gx} = 0 \quad \mu_s N = mg \sin \theta$$

$$N - F_{gy} = 0 \quad \mu_s mg \cos \theta = mg \sin \theta$$

9. A policeman investigating an accident measures the skid marks left by a car. He determines that the distance between the point that the driver slammed on the brakes and the point where the car came to a stop was 34.0 m. From a reference manual he determines that the coefficient of kinetic friction between the tires and the road under the prevailing conditions was 0.300. How fast was the car going when the driver applied the brakes? (This car was not equipped with anti-lock brakes.)

- A) 10.7 m/s
- B) 14.1 m/s**
- C) 21.4 m/s
- D) 32.9 m/s

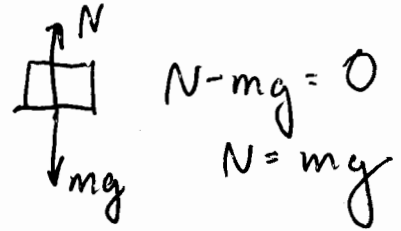
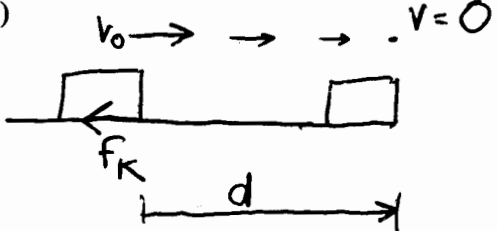

$$-f_k = ma$$

$$-\mu_k N = ma$$

$$N - mg = 0 \quad N = mg$$

$$a = \frac{-\mu_k mg}{m} = -2.94 \text{ m/s}^2$$

$$v^2 - v_0^2 = 2ad$$

$$-v_0^2 = 2(-2.94)(34 \text{ m})$$

10. A car moving at 10.0 m/s encounters a depression in the road that has a circular cross-section with a radius of 30.0 m. What is the normal force exerted by the seat of the car on a 60.0-kg passenger when the car is at the bottom of the depression?

- A) 200 N
- B) 389 N
- C) 789 N**
- D) 589 N

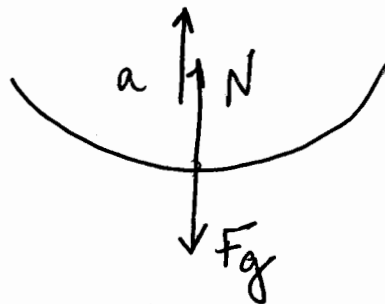
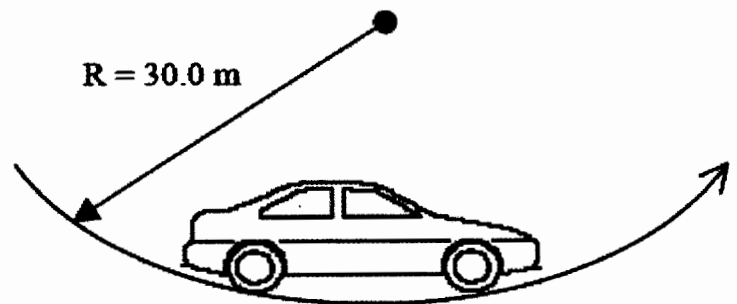

$$N - F_g = ma_c$$

$$N - F_g = \frac{mv^2}{R}$$

$$N = \frac{mv^2}{R} + mg = m \left(\frac{v^2}{R} + g \right)$$

$$= 789 \text{ N}$$

Name _____ Section _____

Part II: Workout problems (10 points each) **IN ORDER TO RECEIVE CREDIT, YOU MUST SHOW YOUR WORK. NO EXCEPTIONS.**

1. A person applies a force T to a block of mass $m=50\text{kg}$ as shown in the figure. The static and dynamic coefficients of friction between the block and floor are 0.5 and 0.1, respectively. The block slides at a **CONSTANT** speed under the applied force T .

(a) Draw a free body diagram indicating the direction of all of the external forces acting on the block (3 points)

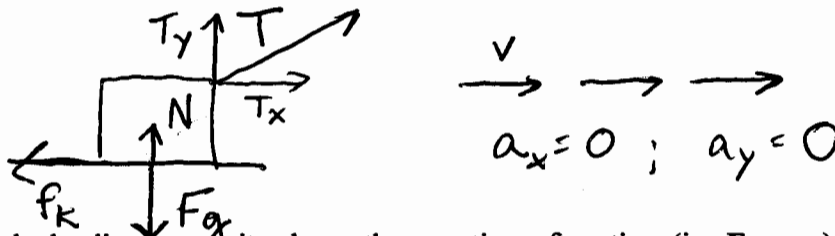

(b) Based on your free-body diagram, write down the equation of motion (ie. $F_{\text{net}}=ma$) for the y direction. (2 points)

$$T_y + N - F_g = 0$$

$$\boxed{T \sin \theta + N - mg = 0} \quad (N = mg - T \sin \theta)$$

(c) Based on your free body diagram, write down the equation of motion (ie. $F_{\text{net}}=ma$) for the x direction. (2 points)

$$T_x - f_k = 0$$

$$\boxed{T \cos \theta - \mu_k N = 0}$$

$$T \cos \theta - \mu_k (mg - T \sin \theta) = 0$$

(d) What force T must be applied so that the block slides at a constant speed? (3 points)

$$T \cos \theta = \mu_k mg - \mu_k T \sin \theta$$

$$T \cos \theta + \mu_k T \sin \theta = \mu_k mg \quad T(\cos \theta + \mu_k \sin \theta) = \mu_k mg$$

$$T = \frac{\mu_k mg}{\cos \theta + \mu_k \sin \theta}$$

$$T = \frac{(0.1)(50\text{kg})(9.8\text{m/s}^2)}{\cos 35^\circ + (0.1)(\sin 35^\circ)}$$

$$T = 55.9 \approx 56\text{N}$$

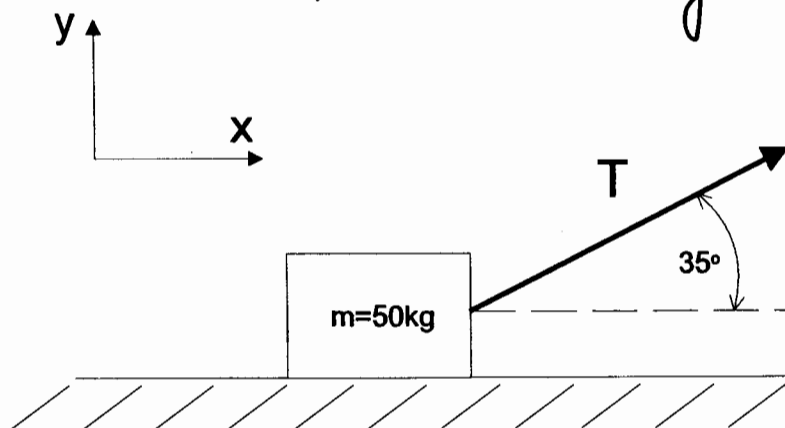

Name _____ Section _____

2. Three masses M_1 (2 kg), M_2 (4 kg) and M_3 (16 kg) are connected by two cables that pass over two pulleys in the system shown below. There is *no friction* present in the system.

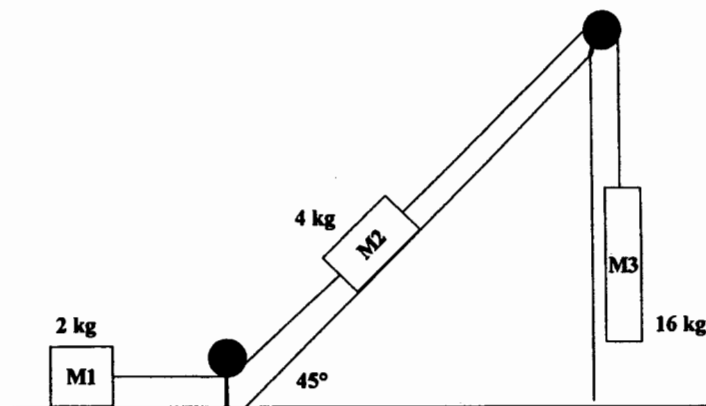

(a) Draw a free body diagram for each mass, indicating the direction of all of the external forces acting on each mass. (4 points)

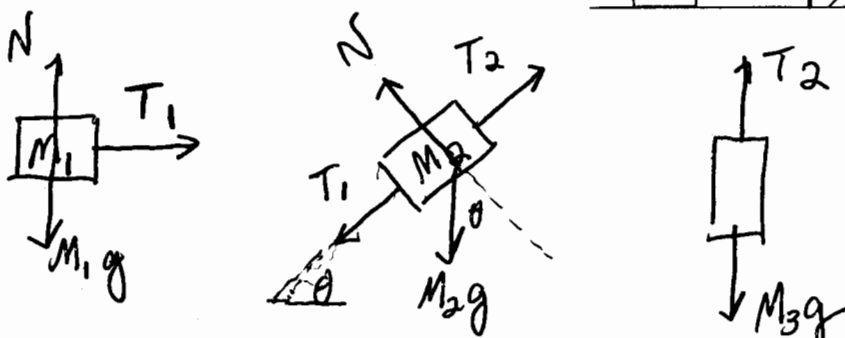

(b) For each mass, indicate the coordinate system you are using to describe its motion. In terms of M_1 , M_2 , M_3 , g , the tensions in both cables and the incline angle, write down the equations of motion (ie. $F=ma$) that can be used to find the acceleration of each mass (4 points).

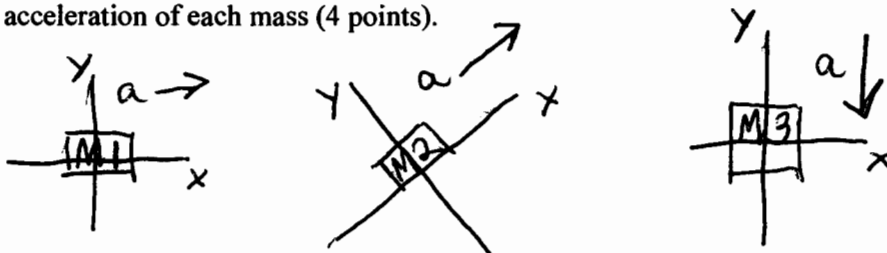

$$T_1 = M_1 a$$

(1)

$$T_2 - M_2 g \sin 45^\circ - T_1 = M_2 a$$

(2)

$$-M_3 g + T_2 = -M_3 a$$

(3)

(c) Determine the acceleration of the entire mass assembly and indicate if M_1 moves to the right, left, or remains stationary. (2 points).

Substitute (1) into (2) $T_2 - M_2 g \sin 45^\circ - M_1 a = M_2 a$

Rearrange (3): $T_2 = M_3 g - M_3 a$

Substitute (3) into (2) $M_3 g - M_3 a - M_2 g \sin 45^\circ - M_1 a = M_2 a$

Group acceleration terms: $M_3 g - M_2 g \sin 45^\circ = M_3 a + M_1 a + M_2 a$

Solve for a : $5.87 \approx 5.9 \text{ m/s}^2$ (M_1 moves to right)