

Name _____

ID _____

Section _____

The exam is closed book and closed notes.**There are 30 multiple choice questions.**

Make sure you put your name, section, and ID number on the SCANTRON form. The answers for the multiple choice Questions are to be placed on the SCANTRON form provided. Use a Number 2 pencil to fill in answers on the SCANTRON form. Make sure you give only one (1) answer to each question. **If you erase an answer on the SCANTRON form, make sure all traces are removed.**

1. One mile is equal to 1609 m; 1 hour is equal to 3600 s. The highway speed limit of 65 mph is equivalent to the speed of:

- A) 1.61 m/s
- B) 18 m/s
- C) 29 m/s
- D) 105 m/s
- E) 1609 m/s

2. A cubic box with an edge of exactly 10 cm has a volume of:

- A) 10^{-9} m^3
- B) 10^{-6} m^3
- C) 10^{-3} m^3
- D) 10^3 m^3
- E) 10^6 m^3

3. The Figure below shows a two-dimensional system of coordinates with the x -axis pointing right and the y -axis pointing up. In vector component notation, vector $\vec{a} = 3\hat{i} - 2\hat{j}$ and $\vec{b} = 3\hat{i} + 2\hat{j}$. The difference of these vectors, $\vec{a} - \vec{b}$, points

- A) up
- B) down
- C) left
- D) right
- E) no direction (the length of $\vec{a} - \vec{b}$ is zero)

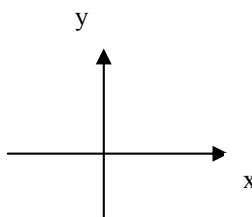

4. The angle between vectors $\vec{a} = 3\hat{i} - 2\hat{j}$ and $\vec{c} = 3\hat{i} + 2\hat{j}$, is equal to

- A) 180°
- B) 0°
- C) 34°
- D) 45°
- E) 67°

Name _____

ID _____

Section _____

5. A 5 kg ball is initially at rest and is dropped from a height of 4.1 m above a table. What is the velocity of the ball just before impact with the table?
- A) 5 m/s
 - B) 9 m/s
 - C) 20 m/s
 - D) 41 m/s
 - E) 80 m/s
6. A particle moves along a straight line with an acceleration of 5.00 m/s^2 to the left but an initial velocity of 10.0 m/s to the right. What is the total DISTANCE TRAVELED (both left and right) by the particle in the first 4.00 seconds?
- A) 10.0 m.
 - B) 20.0 m.
 - C) 40.0 m.
 - D) 60.0 m.
7. Identical guns fire identical bullets A and B horizontally from different heights ($h_A=10 \text{ m}$ and $h_B=20\text{m}$) above the level plane of the ground. The initial speed of the bullet A is the same as that for the bullet B. The air friction can be neglected. Which of the following statements is/are true?
- I. The horizontal distance traveled by the bullet A is smaller than that for the bullet B.
 - II. The flight time for the bullet A is 2 times less than that for the bullet B.
 - III. The flight time for the bullet A is 1.4 times less than that for the bullet B.
 - IV. The magnitudes of velocity of the bullets at impact with the ground are the same.
- A) II only
 - B) I and III
 - C) I and IV
 - D) I, II, and IV
 - E) I, III, and IV
8. A football is thrown toward a receiver with an initial speed of 20 m/s at an angle of 25° above the horizontal. At what horizontal distance the receiver should be to catch the football at the level at which it was thrown?
- A) Impossible to solve; need the mass of the football
 - B) 11 m;
 - C) 21 m
 - D) 31 m
 - E) 41 m

Name _____

ID _____

Section _____

9. Two blocks (X and Y) are in contact on a horizontal frictionless surface. A 36-N constant force is applied to X as shown. The magnitude of the force exerted by Y on X is:

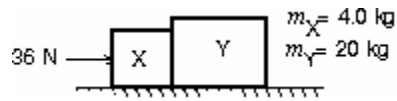

- A) 1.5 N
 B) 6.0 N
 C) 29 N
 D) 30 N
 E) 36 N

10. In the diagram, there are two frictionless surfaces. One is vertical and the other is inclined at 30° from the horizontal. A 500N cylinder rests in the corner formed by the two surfaces. Calculate the force exerted by the vertical wall on the cylinder.

- A) 288 N.
 B) 500 N.
 C) 577 N.
 D) 866 N.
 E) 1000 N.

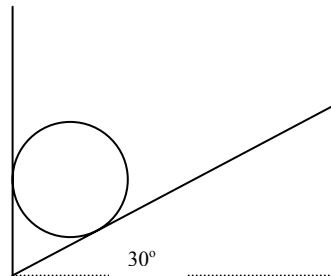

11. A block is at rest on a horizontal plank of wood. The plank is slowly lifted at one end while the other end stays on the floor. If the coefficient of static friction between the block and the plank is 0.5, what is the steepest angle the plank can have before the block begins to slide without being pushed?

- A) 27°
 B) 37°
 C) 45°
 D) 53°
 E) 59°

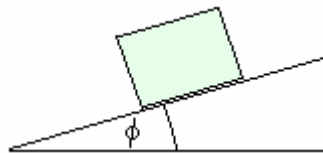

12. For the system of pulleys shown in the sketch, what is the smallest force F that can hold the 2000 N load in place or lift it very slowly. All of the pulleys are massless and frictionless.

- A) 500 N
 B) 330 N
 C) 250 N
 D) 165 N
 E) 125 N

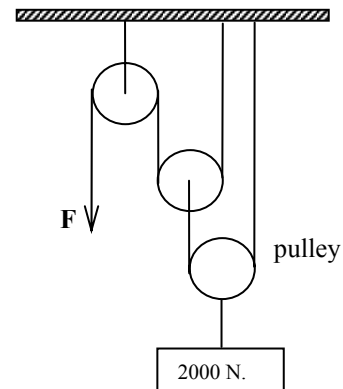

Name _____

ID _____

Section _____

13. Two blocks with the weights of 70-N and 35-N are connected by a string as shown. If the pulley is massless and the surface is frictionless, the magnitude of the acceleration of the 70-N block is:

- A) 1.6 m/s^2
 B) 3.3 m/s^2
 C) 4.9 m/s^2
 D) 6.7 m/s^2
 E) 9.8 m/s^2

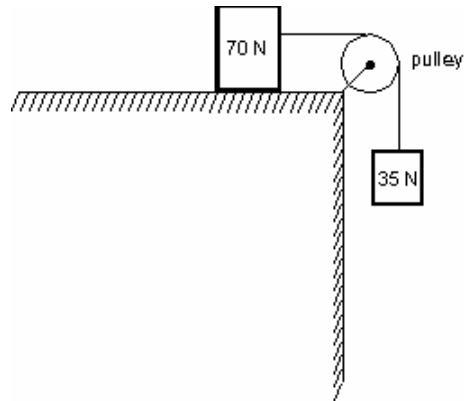

14. A horizontal force F is gradually increased until the 40 kg block begins moving to the right. The 10 kg block cannot move because of the cord attaching it to the wall at left. For what force F does the lower block just start to move?

- A) 14.7 N.
 B) 117.6 N
 C) 132.3 N.
 D) 147 N.
 E) 161.7 N.

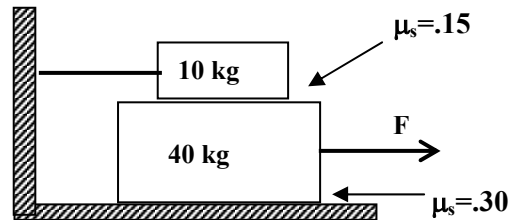

15. If the coefficient of static friction between the tires and road on a rainy day is 0.50, what is the fastest speed at which a car can make a turn with a radius of 80.0 meters?

- A) 7.0 m/s
 B) 11.0 m/s
 C) 14.1 m/s
 D) 20.0 m/s
 E) 25.0 m/s

16. A giant wheel, 40 m in diameter, is fitted with a cage and platform on which a man can stand. The wheel rotates at such a speed that when the cage is at X (as shown), the magnitude of the force exerted by the man on the platform is equal to his weight. The speed of the man is:

- A) 14 m/s
 B) 20 m/s
 C) 28 m/s
 D) 80 m/s
 E) 120 m/s

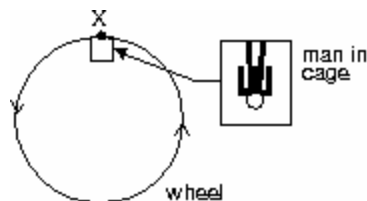

Name _____

ID _____

Section _____

17. The spring constant of the spring shown in the figure is 4.0 Newtons per millimeter (1000 millimeters = 1 meter). The work done in compressing this spring from $x = 40$ millimeters to $x = 60$ millimeters is:

- A) 3.2 J
 B) 4.0 J
 C) 6.0 J
 D) 7.2 J
 E) 8.0 J

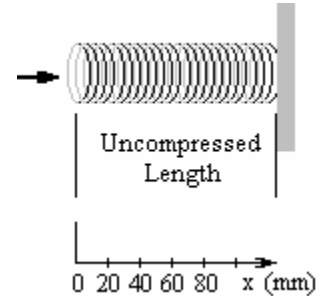

18. A block moves from rest down a frictionless plane. The final speed v_f of the block at the bottom of the plane is most nearly

- A) $\sqrt{2.00}$ m/s
 B) $\sqrt{5.00}$ m/s
 C) $\sqrt{19.6}$ m/s
 D) 4.95 m/s
 E) 9.81 m/s

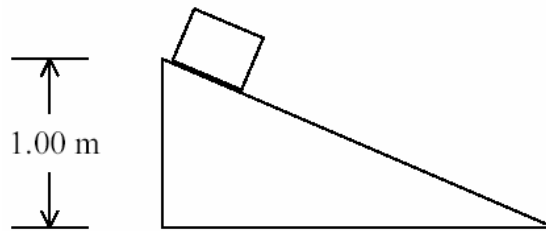

19. The work done on a particle by a constant force is defined as the scalar product $\vec{F} \cdot \vec{d}$. What is the work done by a force $\vec{F} = (20\hat{i} - 15\hat{j})$ N which causes a displacement $\vec{d} = (5\hat{i} - 2\hat{j})$ m?

- A) 130 J
 B) 100 J
 C) 70 J
 D) 30 J
 E) 0 J

Name _____

ID _____

Section _____

20. A 0.5-kg ball is attached to a string, 0.8 m long. The ball is released from the horizontal position as shown in the drawing. What is the speed of the ball at the lowest point?

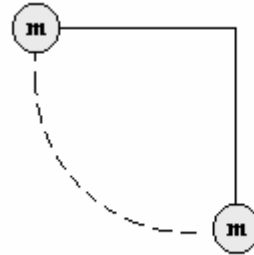

- A) 4.0 m/s
- B) 8.0 m/s
- C) 16 m/s
- D) 20 m/s

21. A 5-kg cart is moving horizontally at 6 m/s. In order to change its speed to 10 m/s, the net work done on the cart must be:

- A) 40 J
- B) 90 J
- C) 160 J
- D) 400 J
- E) 550 J

22. A 5.00-kg block starts from rest and slides 20 m down a frictionless inclined plane as shown. When it reaches the horizontal surface, it encounters a coefficient of kinetic friction of 0.30. How far will it slide on the level surface before it stops?

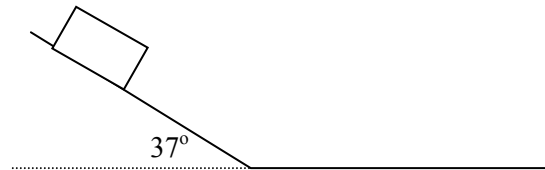

- A) 33.3 m.
- B) 40.0 m.
- C) 50.0 m.
- D) 53.3 m.
- E) 66.7 m.

23. A vertical spring stretches 8 cm when a 1.6 kg block is hung from its end. What is the spring constant of this spring?

- A) 2 N/m
- B) 196 N/m
- C) 890 N/m
- D) 2200 N/m
- E) 8000 N/m

Name _____

ID _____

Section _____

24. An L-shaped piece, represented by the shaded area on the figure, is cut from a metal plate of uniform thickness. The point that corresponds to the center of mass of the L-shaped piece is

A) 1 B) 2 C) 3 D) 4 E) 5

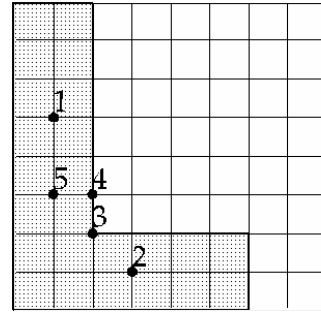

25. A 500-g projectile with a horizontal speed 20 m/s collides with and is embedded in a 2 kg block of wood that is initially at rest on a horizontal frictionless surface. What is the speed of the block after impact?

A) 1 m/s
 B) 4 m/s
 C) 4 km/h
 D) 10 km/h
 E) 20 m/s

26. A ball of mass M is dropped from a height H , strikes the ground, and rebounds to a smaller height. Which of the following statements is correct?

A) Kinetic energy is conserved.
 B) The collision is perfectly elastic.
 C) The collision is perfectly inelastic.
 D) The collision is not perfectly elastic.
 E) None of the above.

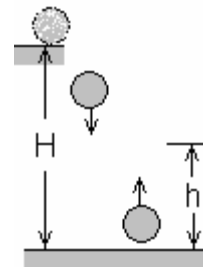

Name _____

ID _____

Section _____

27. In the figure, a bullet of mass 0.01 kg moving horizontally strikes a block of wood of mass 1.50 kg, which is suspended as a pendulum. The bullet lodges in the wood, and together they swing upward a distance of 0.40 m. What was the velocity of the bullet just before it struck the wooden block? The length of the string is 2.00 meters.

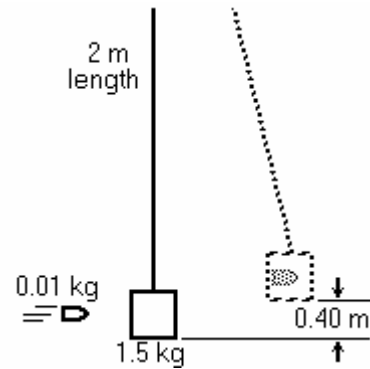

- A) 423 m/s
- B) 646 m/s
- C) 250 m/s
- D) 66.7 m/s
- E) 366 m/s

28. A 0.50-kg bomb is sliding along an icy pond (frictionless surface) with a velocity of 2.0 m/s to the west. The bomb explodes into two pieces. After the explosion, a 0.20-kg piece moves south at 4.0 m/s. What are the components of the velocity of the 0.30-kg piece?

- A) 4.0 m/s north, 0 m/s
- B) 2.7 m/s north, 3.3 m/s west
- C) 4.0 m/s north, 2.7 m/s west
- D) 0 m/s, 2.0 m/s east
- E) 4.0 m/s north, 2.0 m/s east

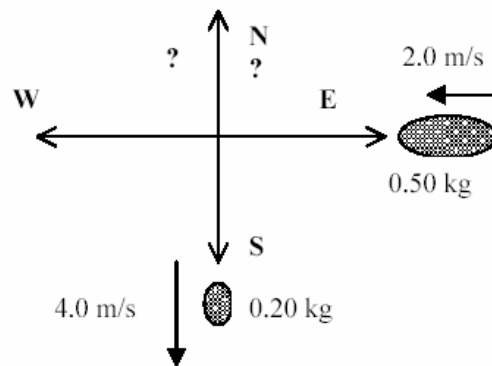

29. A ball strikes the ground and rebounds with the same speed, as illustrated below. Which of the following statements is true:

- A) The change in momentum of the ball is negative
- B) The change in momentum of the ball is zero
- C) The change in momentum in the x-direction is zero
- D) There is no net force acting on the ball
- E) The collision with the ground is completely inelastic

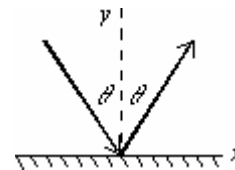

30. Block A ($m = 1.0$ kg) is traveling to the right at 2.0 m/s on a horizontal smooth surface. This block collides head-on with block B ($m = 2.0$ kg) which is moving to the left at 1.0 m/s. After the collision, block A is now moving to the left at 1.0 m/s. What is the velocity of block B after the impact?

- A) 0.50 m/s right.
- B) 0.50 m/s left.
- C) 1.0 m/s right.
- D) 2.5 m/s right.
- E) 2.5 m/s left.

Solutions to Practice final :

1. C
2. C
3. B
4. E
5. B
6. B
7. B
8. D
9. D
10. A
11. A
12. A
13. B
14. E
15. D
16. B
17. B
18. C
19. A
20. A
21. C
22. B
23. B
24. D
25. B
26. D
27. A
28. B
29. C
30. A