

# Critical Periods in the Visual System: Changing Views for a Model of Experience-Dependent Plasticity

Bryan M. Hooks<sup>1,2</sup> and Chinfei Chen<sup>1,2,\*</sup>

<sup>1</sup>Department of Neurology, Neurobiology Program, Children's Hospital, Boston

<sup>2</sup>Program in Neuroscience

Harvard Medical School, 300 Longwood Avenue, Boston, MA 02115, USA

\*Correspondence: [chinfei.chen@childrens.harvard.edu](mailto:chinfei.chen@childrens.harvard.edu)

DOI 10.1016/j.neuron.2007.10.003

Visual system circuitry, a canonical model system for the study of experience-dependent development, matures before and following the onset of vision. Sensory experience or deprivation during an early critical period results in substantial plasticity and is a crucial factor in establishing the mature circuitry. In adulthood, plasticity has been thought to be reduced or absent. However, recent studies point to the potential for change in neuronal circuits within the mature brain, raising the possibility that aberrant circuit function can be corrected. In this review, we will discuss recent exciting findings in the field of experience-dependent plasticity that advance our understanding of mechanisms underlying the activation, expression, and closure of critical periods in the visual system.

## Introduction

The concept of a critical period, a time window wherein the growing brain is most malleable and shows heightened responsiveness to external environment influences, has permeated popular culture. Many parents have adopted the prevailing view that the developing brain is malleable and thus more suited to acquire new information or skills than the mature brain, prompting them to expose their young children to lessons in violin, ballet, or a foreign language. Therefore, the question of what mechanisms underlie the activation and regulation of central nervous system critical periods is of great interest in the field of neuroscience. Manipulation of such mechanisms may potentially allow reactivation of neural circuit plasticity during times when the adult brain is normally less plastic.

The expression "critical period" in the context of the developing mammalian visual system was introduced by the groundbreaking work of [Wiesel and Hubel \(1963\)](#) in their studies in the cat. They described the physiological shift in responsiveness of neurons in the visual cortex to light stimulation when one eye was deprived of vision early in life ([Figure 1](#)). The change in which eye is best able to excite neurons in visual cortex is called ocular dominance (OD) plasticity. This plasticity is most robust during a specific developmental age and diminishes once the cat becomes older ([Hubel and Wiesel, 1970](#)). From these experiments, Wiesel and Hubel proposed that there was a period of development when changes in the external visual environment can alter preexisting neuronal connections.

It is now understood that many regions of the brain have critical periods that occur at different times and are activated and regulated by distinct mechanisms ([Hensch, 2004](#)). Moreover, recent studies have suggested that there is plasticity even after the traditionally defined

closure of the critical period. Perhaps the most telling evidence of this comes from the treatment of amblyopia. In children between the ages of a few months to 7–8 years of age, a variety of conditions causing asymmetric vision, such as a cataract in one eye, can result in functional blindness in the abnormal eye, leading to amblyopia. Until recently, it was believed that if the child was diagnosed after the age of 8, treatment was ineffective because the critical period had closed. However, in 2005, a nationwide randomized clinical trial for treatment of amblyopia in children older than 7 years revealed that treatment of older children up to 17 years of age was effective in about one fourth of patients, although to a lesser degree than treatment of younger children ([Scheiman et al., 2005](#)). Thus the visual system still has residual plasticity later in life. The key is to understand the mechanisms that drive this plasticity.

A conventional view of the time period when vision is required in humans for normal development of spatial acuity, global motion detection, and other visual system characteristics is nicely reviewed by Maurer and colleagues ([Lewis and Maurer, 2005](#)), where cataract studies have given insight into visual development. However, in the present review, we intend to focus on animal models of visual system plasticity, especially the rodent, but also the cat and ferret. Our understanding of plasticity will be drawn from extracellular recordings and synaptic studies, with the caveat that the link between changes at the synaptic level and behavior is not always clear. Specifically, we will discuss recent findings in the literature as well as current debates in the field of critical period plasticity. We will first describe the critical periods defined for various characteristics in visual cortex, as well as subcortical regions. Next, we will address mechanisms involved in the

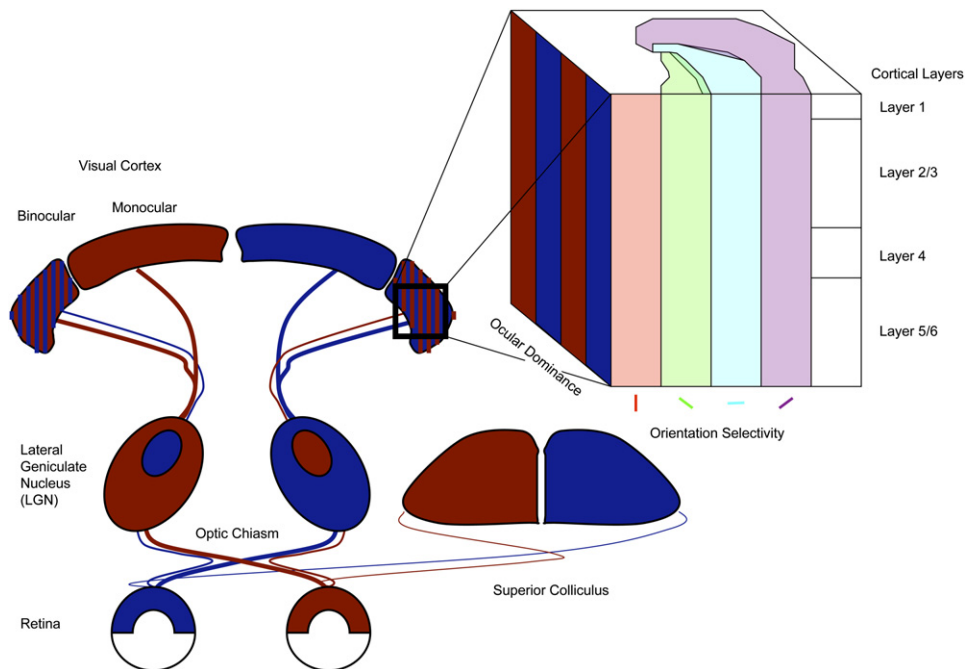

**Figure 1. Schematic of the Mammalian Visual System**

Retina (bottom) feeds forward via the optic chiasm to LGN (above) and superior colliculus (right). Contrasting colors indicate regions receiving input from each eye. LGN eye-specific regions shown as in rodent; more defined laminae exist in cat (three layers) and primate (six layers). The LGN then projects to visual cortex. The binocular zone is smaller and more lateral in rodents. Cat and primate visual cortex shows more overlap of inputs from competing eyes. Organization of the cortex (modeled after the cat or primate) is expanded at top right, showing that a pinwheel of orientation selectivity (pastel colors) and ocular dominance (OD) (contrasting colors) make up a subset of the characters into which cortical space is divided. Such a hypercolumn (Hubel, 1988) is not so regularly organized in every species, and the organization in rat is much less defined than in cat (Ohki et al., 2005, 2006).

triggering and expression of plasticity. Lastly, we will address the possibility of reactivation of plasticity in the adult brain.

### Definition of a Critical Period

Not all neuroscientists agree on what defines a critical period for neural circuit development. One strict interpretation defines the critical period as a subset of sensitive periods (Knudsen, 2004). Sensitive periods are special time windows in early development of an animal where experience has a profound effect on the brain, while critical periods are a special case wherein experience is absolutely required at fixed developmental periods for subsequent normal function. Based on recent studies, discussed below, that show that the timing of OD plasticity can be shifted, OD plasticity would be classified as a sensitive period. In this review, we will define visual system critical periods based on the initial description by Hubel and Wiesel, although we are aware that other researchers in the field may use a different definition. The critical period should include, at a minimum, the onset of robust plasticity in response to sensory experience, a defined period of time when induction of plasticity is possible, and a period of diminished sensitivity when plasticity to the same stimulus no longer occurs. Thus, three phases of plasticity define the critical period:

1. The Precritical period: The initial formation of neuronal circuits that is not dependent on visual experience.
2. The Critical period: A distinct onset of robust plasticity in response to visual experience when the initially formed circuit can be modified by experience.
3. Closure of the critical period: After the end of the critical period, the same visual experience no longer elicits the same degree of plasticity.

The dependence on visual experience varies for different properties of the visual system. In the case of OD function, the preference of cortical cells for one eye or another is already present early in development. However, during the critical period, this preference can be changed with manipulation of visual experience. In other cases, visual experience is needed for the development of a particular feature or for the maintenance of a feature once it has developed. For other features of visual function other than OD, the three distinct periods defining a critical period are not necessarily clearly present, often because they have not been characterized in detail. Thus, the following question arises: do these vision-sensitive changes reflect a critical period? In this review, we will describe well-defined critical periods as well as different forms of developmental processes in the visual system that are sensitive to sensory experience.

### The Precritical Period

Work following that of Hubel and Wiesel has demonstrated that the initial formation of many neuronal circuits in the visual system occurs without the influence of vision. In the case of OD columns, early studies showed that overlapping thalamocortical projections representing the two eyes innervate the cortex early in development, with subsequent refinement in response to visual experience (LeVay et al., 1980). This model, based on anatomical studies labeling one eye with a *trans*-synaptic marker, 3H-proline, has been called into question by recent studies (Crair et al., 1998, 2001; Crowley and Katz, 1999, 2000; Gordon and Stryker, 1996; Horton and Hocking, 1996; Issa et al., 1999), resulting in the prevalent current belief that the initial formation of the OD structure does not depend on vision and occurs before the critical period (Crowley and Katz, 2002; Feller and Scanziani, 2005; Huberman, 2007). Spontaneous activity, however, contributes to the anatomical segregation of thalamocortical inputs into OD columns. Cortical OD organization, as determined by anatomical and physiological assays, is not present when all retinal activity is blocked with tetrodotoxin (TTX), a sodium channel inhibitor, or when retinal waves are disrupted with epibatidine, a nicotinic acetylcholine receptor agonist that inhibits retinal waves (Cang et al., 2005; Penn et al., 1998; Stryker and Harris, 1986). Disruption of OD columns is not simply secondary to aberrant retinogeniculate mapping because retinotopic maps in the cortex are more severely affected than subcortical maps when retinal waves are disrupted (Cang et al., 2005; Grubb et al., 2003; Huberman et al., 2006). Notably, subsequent vision cannot correct the aberrant map. Thus, there appears to be a discrete time window during which retinal waves influence geniculocortical mapping, corresponding to the time when thalamocortical neurons innervate layer 4; disruption of waves after this period does not influence this map (Cang et al., 2005; Huberman et al., 2006). However, there are contradictions in the literature that await clarification. First, enucleation of ferret eyes between postnatal day 1 to 14 (p1–14) does not alter OD structure, while inhibition of retinal activity during a comparable time does (Crowley and Katz, 1999, 2000; Huberman et al., 2006). Second, blockade of all retinal activity or retinal wave activity in cat and mouse result in parallel changes in OD anatomy and physiology (Cang et al., 2005; Stryker and Harris, 1986), while a similar manipulation in ferret results in abnormal anatomy but unaltered physiology (Huberman et al., 2006).

A recent study, however, reported that development of retinotopic maps in the visual cortex, as measured by intrinsic optical imaging, begins at the onset of eye opening and is dependent on vision. In this study, monocular deprivation (MD) appears to retard, but not halt, the normal refinement of the map contralateral to the deprived eye in rats (Smith and Trachtenberg, 2007). By 8–10 days after the onset of vision, the initial difference in refinement of the deprived eye map, when compared to normal controls, is

no longer significant. However, during the vision-sensitive period, correlated activity between the left and right eye, not absolute differences in activity, drives the refinement of the ipsilateral projection. How these findings relate to OD columns before and during the traditional critical period is currently not understood. Anatomical and physiological correlates to the findings of optical imaging will help clarify this relationship.

### The Critical Period

Once the initial neuronal circuits are formed, studies demonstrate a critical period of time during which OD can be modified in response to visual experience (Fagiolini et al., 1994; Gordon and Stryker, 1996; Hubel and Wiesel, 1970; Hubel et al., 1977; Issa et al., 1999; LeVay et al., 1980; Wiesel and Hubel, 1963). This vision-dependent critical period does not always start at the onset of eye opening. Instead, it has been suggested that a critical period cannot commence until the input to the circuit has developed reliability and precision (Knudsen, 2004). Circuits that detect complex features of a visual image, such as face recognition, may show plasticity later than features that respond to simpler features of the environment. In cat, rodent, and ferret, OD plasticity begins after 5–10 days of vision (Fagiolini et al., 1994; Gordon and Stryker, 1996; Hubel and Wiesel, 1970; Issa et al., 1999; Wiesel and Hubel, 1963) (Figure 2). Thus, the cellular mechanisms underlying a critical period are not simply an activity-dependent process. Instead, the sequence of timed events appears to be important. The fact that the precritical period for OD spans into a developmental time period when vision is present suggests that important processes are occurring during the precritical period that contribute to the activation of the critical period. Consistent with this idea, dark rearing has been shown to delay onset of the critical period (Cynader et al., 1976; Fagiolini et al., 1994; Mower, 1991).

OD plasticity is one of the best-studied cortical functions because of the ease of manipulating visual experience independently in the two eyes. However, other features of visual function also exhibit unique profiles in plasticity. In the case of direction sensitivity in kittens, the critical period occurs earlier than that of OD (Daw and Wyatt, 1976). The initial neuronal circuit formed has no preference for a particular direction. Instead, the critical period of refinement for this circuit occurs at the onset of eye opening, after which direction sensitivity emerges days later. Thus, development of direction sensitivity is impaired by dark rearing (Li et al., 2006). During this critical period, the preferred direction of a cell is malleable and changes if the predominant direction of visual experience changes (Daw and Wyatt, 1976). Once the critical period ends, direction selectivity becomes fixed. Unlike OD plasticity, however, dark rearing does not simply delay the onset of the direction selectivity critical period. Development of direction sensitivity does not occur with re-exposure to vision after 3 weeks of visual deprivation in ferrets (Li et al., 2006).

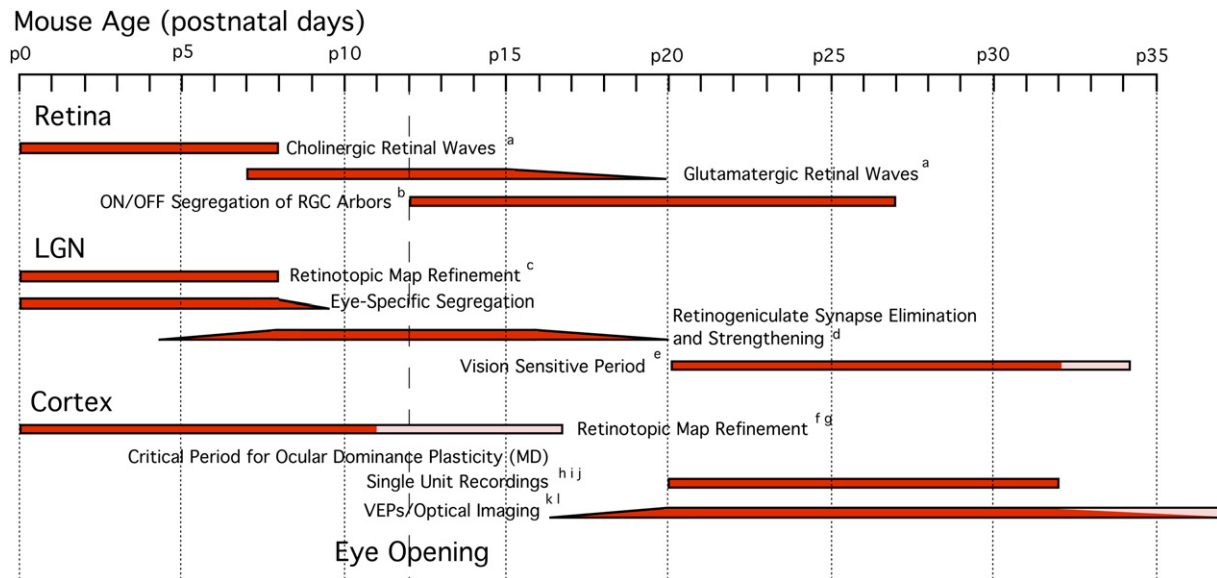

**Figure 2. Timeline of Major Developmental Events in the Mammalian Visual System**

Focusing on the mouse visual system, the developmental timing of important events in retina, LGN, and cortex are presented for comparison with references, after Issa et al. (1999). Triangular regions indicate that the phenomenon is not as robust, or that the phenomenon is waning; for example, the cessation of spontaneous retinal activity. Pink regions indicate points where there is a lack of consensus in the literature. A subset of studies to support these conclusions are: (a) Muir-Robinson et al., 2002; Demas et al., 2003; (b) Tian and Copenhagen, 2003; (c) Pfeiffenberger et al., 2005; (d) Chen and Regehr, 2000; (e) Hooks and Chen, 2006; (f) Cang et al., 2005; (g) Smith and Trachtenberg, 2007; (h) Fagiolini et al., 1994; (i) Gordon and Stryker, 1996; (j) Hanover et al., 1999; (k) Frenkel and Bear, 2004; (l) Hofer et al., 2006.

Whether the initial development of orientation selectivity depends on visual experience has been an issue of debate. Some observe little effect of visual deprivation on orientation selectivity, although the fully developed degree of tuning is not reached (Buisseret and Imbert, 1976; Crair et al., 1998; Sherk and Stryker, 1976). Others find a detrimental effect of visual deprivation on the development of orientation selectivity (Pettigrew, 1974; White et al., 2001). Moreover, a study in ferrets showed that binocular lid suture before eye opening, but not dark rearing, prevents the development of orientation selectivity, suggesting that patterned sensory activity is important (White et al., 2001). Disagreement also exists over whether alterations in the orientation of visual stimuli can shift the orientation preferences of some visual cortical neurons toward the experienced orientation (Sengpiel and Kind, 2002). Some observe experience-dependent changes in orientation preferences and thus argue for an instructive role of visual experience (Blakemore and Cooper, 1970; Sengpiel et al., 1999), while others do not see a shift (Stryker and Sherk, 1975). The different results among these studies may arise from how cells that exhibit reduced responsiveness are categorized and from differences in the assay used. However, most studies agree that prolonged deprivation for more than 3 weeks results in the degradation of orientation selectivity. Thus, there appears to be a discrete period for experience-dependent maintenance of neuronal connections necessary for orientation selectivity. Whether vision is required for maintenance throughout life or only for a discrete time window is still not clear. How-

ever, it appears that the dependence on visual experience in the plasticity of OD, orientation, and direction selectivity is inherently different.

### Sensitive Periods in Subcortical Regions of the Visual System

Synaptic connections in subcortical regions of the visual system, such as the retina and lateral geniculate nucleus (LGN), have traditionally been thought to complete formation and plasticity at an early time in development, before the onset of eye opening. However, recent studies have found a phase of vision-dependent plasticity in subcortical regions with strong parallels to that of the cortex. In the LGN, connections are formed between retinal ganglion cells (RGCs) in the eye and thalamic relay neurons which then segregate into eye-specific layers many days before eye opening (Godement et al., 1984; Jeffery, 1984; Linden et al., 1981; Muir-Robinson et al., 2002; Rakic, 1976; Shatz, 1983; Sretavan and Shatz, 1984, 1986; Ziburkus and Guido, 2006). Correlated spontaneous retinal activity in the form of retinal waves drives this segregation (Galli and Maffei, 1988; Meister et al., 1991; Penn et al., 1998). Once retinal axons reach their appropriate target, they form weak synaptic contacts that subsequently remodel as some retinal inputs strengthen and others are functionally eliminated (Chen and Regehr, 2000; Jaubert-Miazza et al., 2005). The period of this synaptic refinement spans the time of eye opening, and yet, spontaneous activity, not vision, drives this remodeling (Hooks and Chen, 2006).

Similar to the visual cortex, visual thalamus also exhibits a period of experience-dependent plasticity, as recently shown in mice. Although interocular competition occurs between retinal axons prior to eye opening, visual experience-dependent changes occur within eye-specific regions at later stages of life. [Hooks and Chen \(2006\)](#) have shown that retinogeniculate synaptic connectivity can be disrupted by deprivation after 3 postnatal weeks, near the height of the cortical OD critical period. Thus, much like orientation selectivity in the visual cortex, maintenance of the retinogeniculate circuitry requires visual experience almost 1 week after eye opening. However, there are also differences between visual thalamus and cortex development. Dark rearing appears to delay visual function maturation in the cortex ([Cynader et al., 1976](#); [Fagiolini et al., 1994](#); [Mower, 1991](#)), while in the visual thalamus, synapse maturation is not affected by deprivation, but vision is needed to trigger experience-dependent plasticity. Future studies will be needed to determine whether there is a closure to experience-dependent plasticity at the retinogeniculate synapse, and to understand how changes at this connection affect the cortical output of the thalamocortical circuitry.

Like the LGN, mapping of retinal axons to the superior colliculus depends on spontaneous retinal activity and not vision ([Chalupa and Rhoades, 1978](#); [Chandrasekaran et al., 2005](#); [Chow and Spear, 1974](#); [Pfeiffenberger et al., 2006](#); [Rhoades and Chalupa, 1978](#)). However, a recent study examining a number of developmental time points during chronic dark rearing revealed that collicular receptive fields gradually become larger ([Carrasco et al., 2005](#)). Moreover, *in vitro* studies of rat colliculus demonstrate that visual experience can accelerate the normal process of synaptic refinement during development, although the exact synaptic connections that are altered are not clear ([Lu and Constantine-Paton, 2004](#)). Thus the role of vision in the development and maintenance of synapses and synaptic circuits may be a common theme at retinogeniculate circuits, retinotectal circuits, and some cortical circuits of the visual system across species ([Carrasco et al., 2005](#); [Crair et al., 1998](#); [Hooks and Chen, 2006](#)).

Vision has also been shown to play a role in circuit formation of the retina. The refinement of RGC dendritic arbors into ON and OFF regions of the inner plexiform layer, a process that can be accelerated by overexpression of brain-derived neurotrophic factor (BDNF), can be blocked by dark rearing ([Liu et al., 2007](#); [Tian and Copenhagen, 2003](#)). Furthermore, blockade of retinal BDNF expression or enhancement by environmental enrichment was effective in regulating the time course of ON/OFF stratification ([Landi et al., 2007](#)). However, it is currently not clear whether this sensitivity to vision begins as soon as eyes open, or days afterward. Whether dendritic arbors continue to be sensitive to sensory manipulations in adulthood is also undetermined. Thus it is difficult without further characterization to determine whether development of the retina also exhibits a critical period.

### Critical Period Induction

Characterization of visual circuit plasticity in animals not previously manipulated describes the developmental timing of a critical period. However, several manipulations have shown that critical period onset and closure are not fixed ages in the life cycle of the animal, but that critical period timing can be regulated by physiological and molecular manipulations. Experiments that alter this developmental timing offer insight into the mechanisms underlying critical period onset or closure. The use of the mouse, a genetically tractable animal model, for studying critical period plasticity has contributed to the identification of some of these mechanisms.

Using rodent OD plasticity (see [Figure 2](#) for developmental timelines), it has been shown that chronic dark rearing from birth delays critical period onset ([Fagiolini et al., 1994](#)). A plausible explanation for this observation involves BDNF playing a similar role in maturation of visual cortex as to that described above for retina ([Landi et al., 2007](#); [Liu et al., 2007](#)). Expression of BDNF in the visual cortex has been shown to increase following light stimulation in mice ([Bozzi et al., 1995](#); [Cabelli et al., 1996](#); [Castren et al., 1992](#); [Schoups et al., 1995](#)), and overexpression of BDNF in a mouse line resulted in premature onset and closure of the critical period ([Hanover et al., 1999](#); [Huang et al., 1999](#)). Consistent with these findings, dark rearing would reduce BDNF levels and delay the critical period. Furthermore, increasing cortical BDNF levels in dark-reared mice, either by transgenic approaches or environmental enrichment, resulted in normal critical period for OD plasticity ([Bartoletti et al., 2004](#); [Gianfranceschi et al., 2003](#)). Notably, BDNF was also found to play a role in the development of intracortical inhibition ([Huang et al., 1999](#)). This finding has led to an interest in the role of inhibitory circuits in triggering OD plasticity, resulting in a number of exciting findings over the past decade. A series of papers from the Hensch, Fagiolini, and Stryker labs has shown that reduction in GABAergic transmission (by GAD65 knockout) in juvenile mice prevents induction of OD plasticity, but normal OD plasticity can be rescued by infusion of diazepam to potentiate inhibitory transmission ([Hensch et al., 1998a](#)). The deficit in plasticity can be rescued by diazepam infusion in young mice, which results in OD plasticity before the traditionally recognized critical period. But similar plasticity cannot be induced by diazepam in adult animals once the critical period has passed ([Fagiolini and Hensch, 2000](#)). On the other hand, diazepam infusion can trigger OD plasticity at any time in life for GAD65 mice, where the inhibitory threshold is not normally reached. An earlier triggering of the critical period by diazepam in these mice, however, precludes later plasticity, consistent with the BDNF overexpression model ([Huang et al., 1999](#)).

To look at which inhibitory circuits are involved in triggering plasticity, the Hensch group looked at mutants for various GABA receptor subunits that might correspond to specific circuits. Genetically altered mice in which various GABA<sub>A</sub>R  $\alpha$ -subunits have been mutated to render

them insensitive to benzodiazepines show that inhibitory circuits containing the GABA<sub>A</sub>R  $\alpha$ 1 subunit are required for precritical period induction of OD plasticity by diazepam infusion (Fagiolini et al., 2004). This implicates fast-spiking large basket cells in triggering of OD plasticity. The most recent data from this line of investigation add that development of a specific level of perisomatic inhibition, consistent with parvalbumin-positive interneuron circuits, triggers OD plasticity (Katagiri et al., 2007). The role for GABAergic inhibition in regulation of interocular competition may not be restricted to mouse, as OD column development in cat is also disrupted by manipulations of inhibitory neurotransmission (Hensch and Stryker, 2004).

### Physiological Mechanisms of Critical Period Expression

Having defined the critical period and explored the developmental timing of visual system plasticity, we seek to understand what, precisely, is changing in the nervous system following alterations in visual experience. There are several caveats, however, to consider in assigning changes in cortical responsiveness to particular synaptic changes. Changes in environmental experience can affect multiple facets of the sensory system. Deprivation, for instance, may affect not only OD, but also other features detected in a stimulus, such as orientation and direction selectivity. Thus, concluding that plasticity at a particular synapse underlies OD plasticity rather than direction selectivity may prove difficult, especially in a slice preparation. Second, the synaptic changes underlying a shift in OD may occur at multiple synapses. For example, changes may occur at the retinogeniculate synapse, the thalamocortical projection to layer 4, and layer 4 to layer 2/3 connections (Figure 3). Furthermore, there may be multiple forms of synaptic plasticity occurring. When one eye is deprived, not only is the pattern of afferent excitation changing, but the overall level of activity is affected. Thus, homeostatic changes may occur as well (Desai et al., 2002; Goel and Lee, 2007; Maffei et al., 2004).

Lastly, the underlying cortical circuits are not completely characterized: clearly, the circuitry in primary visual cortex is complex! Although anatomical studies of cortical neurons indicate where axons and dendrites arborize, cortical neurons form functional connections with specific partners that are not captured by the shape of the cell (Shepherd et al., 2005). Instead, to study functional connections, one effective approach has been the use of photostimulation (Callaway and Katz, 1993). Such mapping has been performed for a range of cell types in layer 2/3 (Dantzker and Callaway, 2000; Yoshimura et al., 2005) and layer 6 (Zarrinpar and Callaway, 2006), revealing subtle local circuits between layer 4 and layer 2/3. Furthermore, mapping of connections outside primary visual cortex, such as specific projections to areas MT and V2 by distinct neuronal subtypes (Nassi and Callaway, 2007), will be necessary to fully understand vision beyond V1. However, such circuit mapping may not capture all intra-

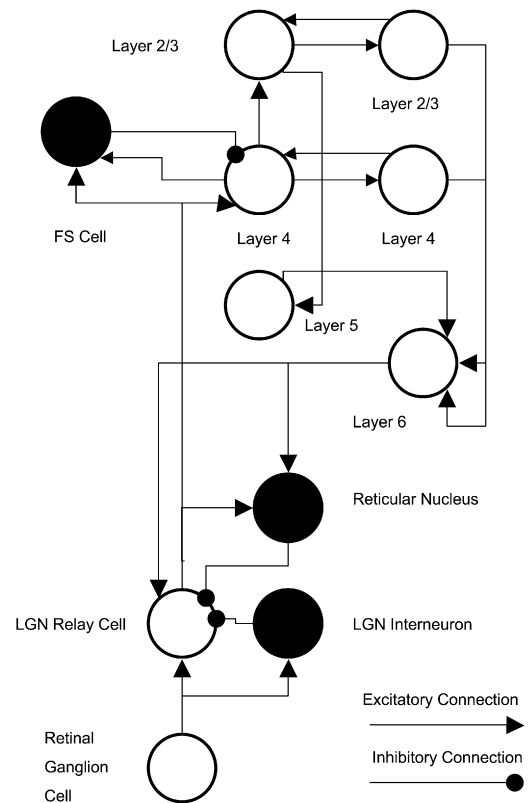

**Figure 3. Block Diagram of the Major Synaptic Connections of the Visual System from Retina to V1**

Cell types are shown schematically as light (excitatory) and dark (inhibitory) neurons. Synaptic connections (arrows, excitatory; circles, inhibitory) are shown; size of connections is a rough indication of connection strength. The major feedforward pathway illustrated is from retina to LGN to layer 4 to layer 2/3. Many other pathways are not illustrated.

cortical circuits. For example, a recent report of rapid feedforward inhibition between layer 2/3 pyramidal cells in mouse visual cortex suggests previously unknown triadic inhibitory circuits exist in visual cortex (Ren et al., 2007). Further mapping of cortical circuitry will thus enhance our understanding of visual cortical plasticity. After identifying the principal circuits, then, the next step will be to address how they change following experience or deprivation.

To begin to explore the specific connections involved, then, several groups have looked at the laminar distribution of OD shifts following MD. Since thalamocortical arbors appear to form OD columns in layer 4 of visual cortex (Crowley and Katz, 1999, 2000), this synapse would be the first layer of cortex that might show OD plasticity. Indeed, plasticity in thalamocortical arbors occurs during MD. Anatomical changes happen slowly, and are present after 1 week following eyelid closure in cat (Antonini and Stryker, 1993). Such anatomical shifts in afferents to layer 4 are also governed by similar factors that regulate physiological shifts in ocular preference: the spacing of layer 4 OD

columns is bidirectionally regulated by enhancement or inhibition of GABAergic circuits in cat (Hensch and Stryker, 2004). However, it is not the only cortical layer, nor the first cortical region, to express OD plasticity. Physiological plasticity outside of the thalamorecipient layer precedes changes in layer 4 arborization. Recordings by Trachtenberg et al. (2000) suggest that OD plasticity is expressed rapidly following 24 hr of MD in kitten in layers 2/3, 5, and 6, but similar physiological shifts are not seen in layer 4 after short deprivation. Thus, the synaptic localization of OD shifts is not limited to layer 4 inputs, but includes afferents in other layers. Structural plasticity on a smaller scale, such as growth and retraction of spines, however, may underlie this functional plasticity (see Mataga et al., 2004; Oray et al., 2004, discussed below).

The ability to follow changes in response of the same cells during chronic recording has lent further insight into the time course in which changes occur in layer 2/3 neurons. The development of a technique for chronic implantation of recording electrodes permits repeated sampling of the same brain region before and after manipulations that alter visual experience (Porciatti et al., 1999). Chronic visually evoked potential (VEP) recordings in adolescent mice at the height of the critical period (p28–35) show that depression of deprived eye responses occurs relatively fast (within 3 days), while potentiation of nondeprived (ipsilateral) eye responses takes longer (5–7 days; [Frenkel and Bear, 2004]). Neural activity within the deprived eye seems required for depression of deprived-eye responses, since monocular inactivation (MI) with TTX resulted in no weakening of these responses, although the amplitudes of competing eye responses were strengthened (Frenkel and Bear, 2004). These changes in layer 2/3 excitation were confirmed by *in vivo* calcium imaging of bulk-loaded layer 2/3 cells (Mrsic-Flogel et al., 2007). Although these studies do not directly identify which synapses are affected, they do suggest the kinetics with which changes occur. One straightforward interpretation is that weakened responses represent long-term depression (LTD) of excitatory connections, while enhanced responses are due to long-term potentiation (LTP) of excitatory connections, though these hypotheses would be strengthened with independent confirmation from intracellular recordings. However, other circuit changes may occur, including strengthening of inhibitory circuits and changes in the connectivity of glutamatergic afferents.

The role of LTP and LTD in OD plasticity is hotly debated. Consistent with the findings that the effects of MD occur with different latencies depending on the cortical layer concerned, LTP and LTD also show laminar differences in mechanism, as reviewed in Daw et al. (2004). Moreover, there is an age-dependent decline in LTD, but not LTP, at the layer 4 to 2/3 excitatory synapse (Kirkwood et al., 1997). Connecting LTP and LTD at a specific synapse to OD plasticity, however, has been frustrating. For example, consistent with reduction in VEPs following deprivation, a study of excitatory inputs to both layer 4 and

layer 2/3 in mouse found that LTD of these connections was occluded in visual cortex contralateral to the deprived eye (Crozier et al., 2007; Heynen et al., 2003). This result suggested that 3 days of *in vivo* deprivation resulted in LTD through similar mechanisms.

However, several genetic mutations in mice have been shown to independently disrupt OD without altering LTD or LTP, and vice versa. Some find that GAD65 knockout mice, which lack normal OD plasticity, show no deficit in induction of LTP or LTD in layer 2/3 of mouse binocular visual cortex (Hensch et al., 1998a), while similar studies at younger ages show absence of LTD (Choi et al., 2002). In addition, a mutant that disrupts mGluR-dependent LTD does not alter the normal OD shifts in response to MD (Renger et al., 2002), though mGluR LTD is not the only form of synaptic depression in visual cortex.

Similarly, though PKA has been implicated in OD shifts (Beaver et al., 2001), studies exploring the connection of PKA in LTD and OD have also been used to argue for or against a role for LTD in OD plasticity. Loss of one PKA regulatory subunit disrupts LTD, but not OD (Hensch et al., 1998b), while loss of a different subunit leaves LTD intact but disrupts OD plasticity (Rao et al., 2004). Alternatively, a study of the predominant cortical regulatory subunit of PKA indicates that the subunit RII beta is required for OD plasticity and LTD, though LTP is not disrupted (Fischer et al., 2004). The disparity in the results from these studies could be explained by the fact that different PKA regulatory subunits are known to localize this enzyme to distinct subcellular domains and that the expression of these subunits may vary among the different types of cortical neurons.

Consistent with a role for LTP and LTD in experience-dependent modifications, alterations of synaptic strength based on the relative timing of presynaptic and postsynaptic depolarization (spike-timing-dependent plasticity, or STDP) have been beautifully demonstrated in visual cortical slices from 2- to 5-week-old rats (Froemke and Dan, 2002), though age did not result in a decline in plasticity. Furthermore, *in vivo* pairing of visual stimuli with a depolarizing current pulse is capable of modifying the receptive field of pyramidal cells in the superficial layers of p16–21 rat visual cortex (Meliza and Dan, 2006). Thus, it seems likely that STDP plays a role in cortical receptive field modifications, though whether this mechanism declines in importance as the critical period closes is unknown.

Instead of extracellular stimulation, the Turrigiano laboratory (Maffei et al., 2004) made paired recordings from neurons in monocular visual cortex. This enabled functional and anatomical definition of cell types, and specified the presynaptic partner in the synapse under study. Thus, synaptic connections between defined cell pairs could be compared across different treatments. Here, synaptic changes were shown to vary with the age at the time of visual deprivation: excitatory connections between layer 4 star pyramidal cells were strengthened by deprivation during a precritical period (Maffei et al., 2004), whereas they

were unchanged by similar deprivation a few days later during the critical period (Maffei et al., 2006). Most notably, inhibitory connections from fast-spiking interneurons to layer 4 star pyramidal cells were potentiated by visual deprivation (Maffei et al., 2006). The involvement of inhibition in OD plasticity is an idea advanced by other groups. Changes at inhibitory synapses provide an alternative explanation for changes in the amplitude of VEP recordings. Thus, in addition to changes in excitatory circuits, such as LTP and LTD, changes in inhibitory connections may also occur during OD shifts. Since the paired recordings were made in monocular visual cortex, however, the observed changes do not directly address OD plasticity, but instead highlight that distinct changes occur at specific synapses, and that plasticity of inhibitory connections has a role to play in experience-dependent plasticity as well. Such an approach in binocular regions may be difficult to interpret if changes in ipsilateral and contralateral circuits cannot be separated.

Homeostatic synaptic changes may also occur in response to altered levels of visual activity (Desai et al., 2002; Turrigiano et al., 1998). An interesting finding from *in vivo* calcium imaging seems to confirm that this mechanism is at work during visual deprivation: although the deprived eye generally loses its ability to excite visual cortical cells that receive inputs from both eyes, the level of synaptic drive to cells dominated by the deprived eye would fall during deprivation, and, indeed, a homeostatic increase in responsiveness for these cells is observed (Mrsic-Flogel et al., 2007).

Thus, it is likely that MD results in multiple modes of change in synaptic strength. These changes need not be mutually exclusive. Development of inhibition required to induce cortical plasticity does not exclude the possibility that, during MD, both feedforward excitation and local inhibitory circuits are modified. Thus, we conclude that several synaptic mechanisms, including changes in inhibitory circuitry, homosynaptic depression and potentiation, and global changes in circuit gain may all occur during visual system plasticity.

### Exploring Molecular Mechanisms of Visual Cortical Plasticity during the Critical Period

A complete understanding of critical period plasticity requires linking the systems-level change in circuit function with the molecular mechanisms that make circuit changes possible. This would be most straightforward if the molecular substrates for plasticity could be shown to be present and act in response to changes in visual experience at some ages but not others. Knowledge of the time and place at which plasticity is expressed opens the possibility of studying the molecular mechanism underlying these changes by assessing the cells involved for changes in gene expression, protein translation, or covalent modifications to potential signaling molecules using a variety of biochemical techniques. Long-lasting circuit changes are believed to require changes in gene expression. Thus, several groups have attempted to identify sets of genes

that are regulated in response to visual experience or deprivation.

High-throughput analysis of mRNA expression is now being used to start exploring plasticity mechanisms in cortex. This has been greatly aided by the ability to use microarray data to look at changes in expression of thousands of genes in cat and monkey (Lachance and Chaudhuri, 2004; Prasad et al., 2002), though earlier screens using differential cDNA cloning (Nedivi et al., 1993) have also identified genes involved in neuronal plasticity. Ossipov et al. (2004) implicated kinase signaling pathways as key regulators of plasticity in rodent visual cortex, and this has been confirmed in subsequent studies. Genes whose expression could be altered during the height of the critical period are good candidates for plasticity regulators, and two recent extensive studies in mouse have provided new insight: the Sur laboratory (Tropea et al., 2006) identified the involvement of the IGF1 receptor pathway in OD plasticity using a similar microarray screen. Another independent screen identified five genes expressed during the height of the cortical critical period; other visual cortical genes, such as *BDNF* and *Fos*, are regulated by visual experience at all times of development (Majdan and Shatz, 2006).

mRNA harvesting for microarray analysis typically requires microdissection of the appropriate brain region, such as visual cortex. Tissue collection of all laminae of visual cortex, however, lumps together a great variety of cell types. Individual cell types show a great diversity of gene expression (Nelson et al., 2006), and may be expected to show differences in plasticity of gene expression as well, consistent with the lamina-specific (Trachtenberg et al., 2000) and cell-pair-specific (Maffei et al., 2004, 2006) synaptic plasticity induced by deprivation. Thus, a more specific question that will address the mechanism of *in vivo* induction of sensory system plasticity is which genes regulate synaptic plasticity of a specific cell type, and which determine the system-level function of that cell. This enterprise will be greatly aided by techniques to identify and sort individual cell types for analysis.

Examination of previously described activity-dependent genes has also identified candidate signaling pathways in critical period plasticity. Two groups found involvement of ERK signaling upstream of the CREB pathway (Di Cristo et al., 2001; Pham et al., 1999). Moreover, using a transgenic *Cre-lacZ* reporter system, the Stryker lab has shown that MD activates transcription of genes under the control of CRE elements, and does so prior to the functional expression of an OD shift. This expression took 12 hr to induce—not as fast as some Immediate Early Genes (IEGs [genes regulated within minutes following neuronal stimulation]), but more rapidly than OD shifts (Pham et al., 1999). Furthermore, *LacZ* expression is more heavily induced in response to deprivation at p27 (during the critical period) than in adult mice (Pham et al., 1999). During the cortical critical period, induction occurred mainly in visual cortical regions innervated by the deprived eye, though, interestingly enough, not in the thalamus. Instead, CRE activation in thalamus plays a role earlier in



development, during segregation of retinal axons into eye-specific layers (Pham et al., 2001). ERK signaling activated by visual experience may regulate gene expression by covalent modification of histones (Putignano et al., 2007). This study found that increased histone acetylation and phosphorylation was detected following visual experience. Furthermore, pharmacological stimulation of histone acetylation facilitated OD plasticity in older animals.

The intensity of induction of the IEG *Arc* in layer 4 of visual cortex has been proposed as a molecular marker for OD shifts in visual cortex (Tagawa et al., 2005). *Arc* is regulated by visual experience, and can be manipulated by 4 days of visual deprivation not simply during the critical period, but also as early as p17 and as late as 13 weeks. These findings suggest that some form of plasticity in the visual cortex of mice is possible outside the normal critical period. Sorting out whether physiologically defined OD plasticity is possible in the adult would support this claim, though different recording techniques have yielded different results (Fagiolini and Hensch, 2000; Hofer et al., 2006; Sawtell et al., 2003). An additional role for *Arc* in regulation of orientation selectivity was proposed by the Tonegawa group (Wang et al., 2006), where replacement of the *Arc* gene with GFP restricted development of orientation selectivity in visual cortex.

Recruitment of glia following brain trauma or stress seems to be associated with dendritic spine turnover, suggesting that glia may also play an acute role in regulating spine growth and retraction (Xu et al., 2007). This phenomenon appears to explain the difference between spine growth and retraction rates observed using a thinned skull versus open skull technique, though it remains to be shown whether microglial activation plays a role in synapse formation and stabilization under in vivo conditions. The potential involvement of the complement cascade in retinogeniculate synapse refinement (Stevens et al., 2007) suggests one molecular means by which neurons could designate certain synapses for preservation or elimination. Thus, microglia may play a role in synapse maturation, possibly by phagocytosis of unwanted or inappropriate connections. It will be interesting to see if this cascade is involved in multiple levels of the visual system, as well as to explore the molecular mechanisms by which certain connections are marked. However, there is no evidence to suggest that pathways involved in degradation of the extracellular matrix contribute instructively to the selection of which connections to maintain or degrade, but they instead seem permissive for functional changes in response to experience.

Consistent with a role for the extracellular matrix in regulation of synaptic plasticity, in vivo imaging of somatosensory cortex revealed developmental and experience-dependent changes in rates of spine formation and retraction (Holtmaat et al., 2006; Zuo et al., 2005). Changes in spine morphology require plasticity in the extracellular matrix, as reviewed in Berardi et al. (2004). Thus, it is not surprising that proteolysis should be implicated in cortical plasticity. Several groups have reported

a role for proteolysis facilitated by tissue plasminogen activator (tPA) in regulation of spine motility (Mataga et al., 2004; Oray et al., 2004) and thus experience-dependent changes. Visual cortical neurons become enclosed in a lattice-like structure (called perineuronal nets, PNN) of chondroitin-sulfate proteoglycans (CSPGs, which tend to inhibit outgrowth) over development with a time course that corresponds to the closure of critical period plasticity. A potential role for CSPGs (Zaremba et al., 1989) in regulation of cortical plasticity was shown in normal and deprived cats, where immunoreactivity was regulated by experience (Guimaraes et al., 1990; Zaremba et al., 1989). Manipulation of CSPGs, such as manipulation by degradation, can restore plasticity to adult cortex (Pizzorusso et al., 2002, 2006). The Kolodkin group has shown that CSPG interactions with Semaphorin 5A may mediate repulsive interactions with growth cones (Kantor et al., 2004), thus potentially linking PNN development with a transmembrane receptor. A similar restrictive role of the extracellular environment in limiting OD plasticity following the critical period has been shown using knockout animals for the Nogo-66 receptor and Nogo-A/B (McGee et al., 2005). Knockout animals showed OD plasticity at adult ages (after p40 and p120) when wild-type mice do not respond to MD. It will be interesting to learn the degree to which myelination can be developmentally regulated by experience.

The presence or absence of a certain molecule during periods of high plasticity is not the only pattern observed in molecular mechanisms underlying the critical period. For example, NMDARs are believed to play a role in a variety of forms of in vivo plasticity, including OD (Sawtell et al., 2003). The slower time course of NMDARs containing the NR2B subunit, relative to NR2A-containing receptors, has been implicated in enhanced plasticity of younger animals, since NR2B is expressed early and replaced by NR2A in many brain regions. NMDARs are also calcium permeable, which may aid in activation of intracellular signaling and gene regulation. However, the initial suggestion that developmental shortening of NMDAR currents by a subunit change from NR2B to NR2A closes the critical period (Carmignoto and Vicini, 1992) needs revision, as animals lacking NR2A do not show a developmental lengthening of the critical period (Lu et al., 2001; Fagiolini et al., 2003). This last work, however, finds compelling evidence that mechanisms underlying development of different attributes of visual system circuits (in this case, OD and orientation selectivity) may differ in their requirement for NR2A.

Lastly, as we discuss in our section on induction of plasticity, BDNF may regulate the onset of plasticity. By cortical overexpression of BDNF, Huang and colleagues (Huang et al., 1999) were able to elicit precocious onset and early closure of the critical period. This not only implicated neurotrophins in critical period plasticity, but furthermore suggested that, although the critical period may be triggered early, it would not remain open indefinitely, a theme reviewed in Hensch (2005).

### Closure of the Critical Period and Reactivation of Plasticity

An interesting question at hand is what regulates the closure and reactivation of the critical period. Hubel and Wiesel documented a gradual reduction in OD plasticity in kittens 8 weeks after the sudden onset of sensitivity to deprivation (Hubel and Wiesel, 1970; Wiesel and Hubel, 1963). Subsequent studies revealed a longer and slower termination of OD plasticity that extended out to 1 year in cells located in layers 2/3, 5, and 6 of cat (Cynader et al., 1980; Daw et al., 1992; Jones et al., 1984). Continued functional and anatomical plasticity is also observed in mice many weeks after the peak of the critical period, although the degree of change is weaker (Antonini et al., 1999). The state of the neuronal circuit becomes fixed following closure. Deprivation after critical period closure did not result in the robust shift in OD columns. For other features of visual function, the closure of a critical period is less characterized. It is known that closure of the critical period for direction selectivity occurs before that of OD plasticity. However, whether vision plays a necessary role in maintenance of orientation selectivity throughout life is undetermined.

In addition to changes in the extracellular matrix, development of GABAergic inhibition may influence the closure of the critical period. Experiments in GAD65 mice where the critical period could be activated once, but not subsequently, by diazepam infusion (Fagiolini and Hensch, 2000) have suggested that activation of critical period by intracortical inhibition may be a once-in-a-lifetime phenomenon. Thus, the role of GABAergic inhibition is both triggering onset and, by remaining potent, closure of OD plasticity. Manipulations such as dark rearing (He et al., 2006) and environmental enrichment (Sale et al., 2007) may result in reductions in cortical inhibition, and thus promote adult plasticity.

Closure of the critical period, however, does not mean a complete lack of plasticity. As demonstrated by the clinical experience with amblyopia, the maturing visual system still has the potential for plasticity (Scheiman et al., 2005). While some interpret adult plasticity as a reflection of later termination of the critical period, others will argue that since the plasticity is not as strong as that at younger ages, then these findings represent plasticity that is independent of the earlier critical period plasticity. It is not known, for example, whether the synaptic mechanisms by which the older brain changes are the same as those utilized at less mature ages, and some findings discussed below suggest they differ (Sawtell et al., 2003). Others interpret these findings as an implication of the potential for reactivation of the critical period. Regardless of the interpretation, however, harnessing the mechanisms underlying this plasticity has relevance to a number of human disorders and pathologies.

Thus, studies that demonstrate activation of plasticity outside of developmentally appropriate periods are intriguing. In the barn owl, studies of the tectum, where visual and auditory spatial maps are integrated and aligned,

have uncovered a sensitive period during which a large shift in the visual map will result in eventual realignment of the auditory map so that they are in register again (Brainard and Knudsen, 1998; Knudsen and Brainard, 1991). In juvenile barn owls, realignment of the two sensory maps takes several months. In contrast, in adult owls, very little plasticity occurs over an equivalent time period. However, Knudsen and his colleagues found that plasticity could be induced in adult owls if visual map shifts were smaller and incremental (Linkenhoker and Knudsen, 2002). Thus, they concluded, the potential for plasticity is present—the key is to decipher how to tap into this potential.

In rodents, however, there is disagreement about the degree of plasticity that remains in adults in response to prolonged deprivation. Induction of cortical OD plasticity later in life is not necessarily prohibited, but it may simply require a longer-lasting or potent stimulus to induce it. The Bear lab (Sawtell et al., 2003) has shown that prolonged MD results in OD plasticity even in adult mice, suggesting that the threshold for plasticity is not absent but higher in adult mice. Others find adult plasticity with MD as brief as 5 days in adult (Hofer et al., 2006), and some studies report more rapid changes (Fischer et al., 2007). Evidence of plasticity in single-unit recordings of adults may require longer deprivation to emerge, however, as Fagiolini and Hensch (2000) find that 15 day MD produces no shift in the mature mouse.

Resolving the disagreement of the degree of adult plasticity will be a complicated matter, as some groups use single-unit recordings in visual cortex, a technique well-suited to detect action potential firing but possibly biased toward larger cell types. Imaging endogenous flavoprotein fluorescence, a marker for cellular metabolic activity, yields similar results, showing OD plasticity in mouse at p28, but not in adults (Tohmi et al., 2006). Other groups record VEPs, which may represent the response of a larger population of cells and are thought to reflect a combination of action potentials and synaptic potentials; intrinsic optical imaging may also reflect this combination. More subtle variables, such as the anesthetic chosen for in vivo recordings, may also account for differences in plasticity (Fischer et al., 2007). For example, one study showed significantly more OD plasticity in adult mice anaesthetized with urethane when compared with barbiturates. In contrast, OD plasticity during the critical period is detected by optical imaging of mice anaesthetized by Nembutal, but much less so when urethane is the anesthetic (Cang et al., 2005).

Consistent with the idea that plasticity after the traditional closure of the critical period may act through distinct mechanisms, the expression of plasticity differs between young and old animals. In the case of OD plasticity, which is often assessed functionally as the ratio of VEPs in response to ipsilateral and contralateral eye stimulation, young mice show a weakening of deprived (contralateral) and strengthening of nondeprived eye responses, while older mice show a strengthening of normally weak nondeprived (ipsilateral) eye response (Hofer et al., 2006; Sawtell et al., 2003).

Previous plasticity seems to leave an anatomical or functional trace behind, enabling similar plasticity to occur more easily later in life, as suggested by work from the Knudsen lab (DeBello et al., 2001; Knudsen, 2002; Lindenhoker et al., 2005). Recently, a similar phenomenon was observed in mouse visual cortex by measuring OD using intrinsic optical signals: previous juvenile MD for a short period made induction of OD plasticity in adult mouse occur more rapidly than otherwise possible, in as short as 3 days of deprivation (Hofer et al., 2006). Repeated short periods of deprivation were thus effective at lowering the threshold for OD plasticity in mice. An alternative paradigm for enhancement of OD plasticity in adult rats, after the conventional critical period for this phenomenon has closed, has been proposed by the Quinlan lab (He et al., 2006). Although adult OD plasticity is typically absent in response to brief MD, a 10 day period of complete visual deprivation prior to MD results in activation of a juvenile-like level of OD plasticity. Furthermore, this plasticity is expressed in a manner similar to that in young animals (Frenkel and Bear, 2004), with depression of response to the deprived eye preceding strengthening of ipsilateral response. Promising as a possible treatment for adult amblyopia, rodents can also show functional recovery of visual acuity (He et al., 2007). It will be interesting to determine whether these conditions that elicit plasticity also manifest as changes at the circuit-level output (measured by single-unit recordings) and with anatomical assays.

Another form of adult plasticity is revealed by studies of recovery from MD. The degree of recovery varies depending on species. Classic studies in monkey find reversal of OD shifts in adult animals difficult following MD during the critical period with subsequent return to normal vision (Hubel, 1988; Hubel et al., 1977), even with prolonged recovery times. Some reversal is possible, and enhanced by earlier reverse suturing (Blakemore et al., 1978). In contrast, OD and visual acuity can recover in cats following MD (Mitchell, 1988); this recovery is also enhanced by using reverse suture (Blakemore and Van Sluyters, 1974; Movshon, 1976). The rate of recovery of visual acuity is enhanced by correlated binocular vision, as strabismic cats recover function more slowly (Kind et al., 2002). A recent study also revealed that the recovery of cortical binocularity after the OD critical period can occur in ferrets that have been exposed to previous visual experience (Liao et al., 2004).

It is still not clear why the degree of plasticity seen in both the response to MD and the recovery from MD in adults varies among different species. It will be of interest to identify differences between species at the cellular and molecular level. Moreover, the mechanisms underlying the critical period may be dissociable from those underlying the closure of the critical period, the recovery from deprivation, and the reactivation of plasticity in adulthood. An extensive literature on recovery from amblyopia in primates and cat reveals a complex picture with multiple sensitive periods for development, damage, and recovery (Lewis and Maurer, 2005).

The hope is that the advancement of our understanding of mechanisms underlying these processes will ultimately lead to improved treatments of neurological disorders involving disruptions in neuronal circuitry, such as amblyopia. While the development of new therapies targeting specific molecules may be slow, some variations of noninvasive treatments are worth exploring. Interestingly, in the recent clinical trial for the treatment of older children (>7 years), the practical issues of effectively patching the good eye of school-aged children led to repetitive, intermittent treatments. Rather than long-term manipulations of visual experience, children were transiently patched for 2–6 hr after school. This resulted in repeated short-term manipulations that invoke parallels with the barn owl experiments, although direct extrapolations from animal models to human diseases are not straightforward. It would be interesting, then, to know if gradual training experiments or complete deprivation prior to reverse suture would result in permanent improvement in deprived-eye vision, and whether this improvement would reflect changes inside or outside the primary visual cortex of rodents, cats, and primates. Nonetheless, finding that some plasticity in adult animals is possible is reason to be hopeful, and further work to discover the mechanisms responsible for this plasticity will offer the potential for novel strategies and therapeutics for reorganizing neuronal circuits in the mature nervous system.

#### ACKNOWLEDGMENTS

This work was supported by RO1EY013613 and the Children's Hospital Boston Mental Retardation and Developmental Disabilities Research Center PO1 HD18655. We thank S. Culican for her clinical insights on critical periods, and J. Castiglione for providing continuity over the past few years.

#### REFERENCES

- Antonini, A., and Stryker, M.P. (1993). Rapid remodeling of axonal arbors in the visual cortex. *Science* 260, 1819–1821.
- Antonini, A., Fagiolini, M., and Stryker, M.P. (1999). Anatomical correlates of functional plasticity in mouse visual cortex. *J. Neurosci.* 19, 4388–4406.
- Bartoletti, A., Medini, P., Berardi, N., and Maffei, L. (2004). Environmental enrichment prevents effects of dark-rearing in the rat visual cortex. *Nat. Neurosci.* 7, 215–216.
- Beaver, C.J., Ji, Q., Fischer, Q.S., and Daw, N.W. (2001). Cyclic AMP-dependent protein kinase mediates ocular dominance shifts in cat visual cortex. *Nat. Neurosci.* 4, 159–163.
- Berardi, N., Pizzorusso, T., and Maffei, L. (2004). Extracellular matrix and visual cortical plasticity: freeing the synapse. *Neuron* 44, 905–908.
- Blakemore, C., and Cooper, G.F. (1970). Development of the brain depends on the visual environment. *Nature* 228, 477–478.
- Blakemore, C., and Van Sluyters, R.C. (1974). Reversal of the physiological effects of monocular deprivation in kittens: further evidence for a sensitive period. *J. Physiol.* 237, 195–216.
- Blakemore, C., Garey, L.J., and Vital-Durand, F. (1978). The physiological effects of monocular deprivation and their reversal in the monkey's visual cortex. *J. Physiol.* 283, 223–262.

- Bozzi, Y., Pizzorusso, T., Cremisi, F., Rossi, F.M., Barsacchi, G., and Maffei, L. (1995). Monocular deprivation decreases the expression of messenger RNA for brain-derived neurotrophic factor in the rat visual cortex. *Neuroscience* 69, 1133–1144.
- Brainard, M.S., and Knudsen, E.I. (1998). Sensitive periods for visual calibration of the auditory space map in the barn owl optic tectum. *J. Neurosci.* 18, 3929–3942.
- Buisseret, P., and Imbert, M. (1976). Visual cortical cells: their developmental properties in normal and dark reared kittens. *J. Physiol.* 255, 511–525.
- Cabelli, R.J., Allendoerfer, K.L., Radeke, M.J., Welcher, A.A., Feinstein, S.C., and Shatz, C.J. (1996). Changing patterns of expression and subcellular localization of TrkB in the developing visual system. *J. Neurosci.* 16, 7965–7980.
- Callaway, E.M., and Katz, L.C. (1993). Photostimulation using caged glutamate reveals functional circuitry in living brain slices. *Proc. Natl. Acad. Sci. USA* 90, 7661–7665.
- Cang, J., Renteria, R.C., Kaneko, M., Liu, X., Copenhagen, D.R., and Stryker, M.P. (2005). Development of precise maps in visual cortex requires patterned spontaneous activity in the retina. *Neuron* 48, 797–809.
- Carmignoto, G., and Vicini, S. (1992). Activity-dependent decrease in NMDA receptor responses during development of the visual cortex. *Science* 258, 1007–1011.
- Carrasco, M.M., Razak, K.A., and Pallas, S.L. (2005). Visual experience is necessary for maintenance but not development of receptive fields in superior colliculus. *J. Neurophysiol.* 94, 1962–1970.
- Castren, E., Zafra, F., Thoenen, H., and Lindholm, D. (1992). Light regulates expression of brain-derived neurotrophic factor mRNA in rat visual cortex. *Proc. Natl. Acad. Sci. USA* 89, 9444–9448.
- Chalupa, L.M., and Rhoades, R.W. (1978). Directional selectivity in hamster superior colliculus is modified by strobe-rearing but not by dark-rearing. *Science* 199, 998–1001.
- Chandrasekaran, A.R., Plas, D.T., Gonzalez, E., and Crair, M.C. (2005). Evidence for an instructive role of retinal activity in retinotopic map refinement in the superior colliculus of the mouse. *J. Neurosci.* 25, 6929–6938.
- Chen, C., and Regehr, W.G. (2000). Developmental remodeling of the retinogeniculate synapse. *Neuron* 28, 955–966.
- Choi, S.Y., Morales, B., Lee, H.K., and Kirkwood, A. (2002). Absence of long-term depression in the visual cortex of glutamic Acid decarboxylase-65 knock-out mice. *J. Neurosci.* 22, 5271–5276.
- Chow, K.L., and Spear, P.D. (1974). Morphological and functional effects of visual deprivation on the rabbit visual system. *Exp. Neurol.* 42, 429–447.
- Crair, M.C., Gillespie, D.C., and Stryker, M.P. (1998). The role of visual experience in the development of columns in cat visual cortex. *Science* 279, 566–570.
- Crair, M.C., Horton, J.C., Antonini, A., and Stryker, M.P. (2001). Emergence of ocular dominance columns in cat visual cortex by 2 weeks of age. *J. Comp. Neurol.* 430, 235–249.
- Crowley, J.C., and Katz, L.C. (1999). Development of ocular dominance columns in the absence of retinal input. *Nat. Neurosci.* 2, 1125–1130.
- Crowley, J.C., and Katz, L.C. (2000). Early development of ocular dominance columns. *Science* 290, 1321–1324.
- Crowley, J.C., and Katz, L.C. (2002). Ocular dominance development revisited. *Curr. Opin. Neurobiol.* 12, 104–109.
- Crozier, R.A., Wang, Y., Liu, C.H., and Bear, M.F. (2007). Deprivation-induced synaptic depression by distinct mechanisms in different layers of mouse visual cortex. *Proc. Natl. Acad. Sci. USA* 104, 1383–1388.
- Cynader, M., Berman, N., and Hein, A. (1976). Recovery of function in cat visual cortex following prolonged deprivation. *Exp. Brain Res.* 25, 139–156.
- Cynader, M., Timney, B.N., and Mitchell, D.E. (1980). Period of susceptibility of kitten visual cortex to the effects of monocular deprivation extends beyond six months of age. *Brain Res.* 191, 545–550.
- Dantzker, J.L., and Callaway, E.M. (2000). Laminar sources of synaptic input to cortical inhibitory interneurons and pyramidal neurons. *Nat. Neurosci.* 3, 701–707.
- Daw, N., Rao, Y., Wang, X.F., Fischer, Q., and Yang, Y. (2004). LTP and LTD vary with layer in rodent visual cortex. *Vision Res.* 44, 3377–3380.
- Daw, N.W., and Wyatt, H.J. (1976). Kittens reared in a unidirectional environment: evidence for a critical period. *J. Physiol.* 257, 155–170.
- Daw, N.W., Fox, K., Sato, H., and Czepita, D. (1992). Critical period for monocular deprivation in the cat visual cortex. *J. Neurophysiol.* 67, 197–202.
- DeBello, W.M., Feldman, D.E., and Knudsen, E.I. (2001). Adaptive axonal remodeling in the midbrain auditory space map. *J. Neurosci.* 21, 3161–3174.
- Demas, J., Eglén, S.J., and Wong, R.O. (2003). Developmental loss of synchronous spontaneous activity in the mouse retina is independent of visual experience. *J. Neurosci.* 23, 2851–2860.
- Desai, N.S., Cudmore, R.H., Nelson, S.B., and Turrigiano, G.G. (2002). Critical periods for experience-dependent synaptic scaling in visual cortex. *Nat. Neurosci.* 5, 783–789.
- Di Cristo, G., Berardi, N., Cancedda, L., Pizzorusso, T., Putignano, E., Ratto, G.M., and Maffei, L. (2001). Requirement of ERK activation for visual cortical plasticity. *Science* 292, 2337–2340.
- Fagiolini, M., and Hensch, T.K. (2000). Inhibitory threshold for critical-period activation in primary visual cortex. *Nature* 404, 183–186.
- Fagiolini, M., Pizzorusso, T., Berardi, N., Domenici, L., and Maffei, L. (1994). Functional postnatal development of the rat primary visual cortex and the role of visual experience: dark rearing and monocular deprivation. *Vision Res.* 34, 709–720.
- Fagiolini, M., Katagiri, H., Miyamoto, H., Mori, H., Grant, S.G., Mishina, M., and Hensch, T.K. (2003). Separable features of visual cortical plasticity revealed by N-methyl-D-aspartate receptor 2A signaling. *Proc. Natl. Acad. Sci. USA* 100, 2854–2859.
- Fagiolini, M., Fritschy, J.M., Low, K., Mohler, H., Rudolph, U., and Hensch, T.K. (2004). Specific GABAA circuits for visual cortical plasticity. *Science* 303, 1681–1683.
- Feller, M.B., and Scanziani, M. (2005). A precritical period for plasticity in visual cortex. *Curr. Opin. Neurobiol.* 15, 94–100.
- Fischer, Q.S., Beaver, C.J., Yang, Y., Rao, Y., Jakobsdottir, K.B., Storm, D.R., McKnight, G.S., and Daw, N.W. (2004). Requirement for the RIIbeta isoform of PKA, but not calcium-stimulated adenylyl cyclase, in visual cortical plasticity. *J. Neurosci.* 24, 9049–9058.
- Fischer, Q.S., Graves, A., Evans, S., Lickey, M.E., and Pham, T.A. (2007). Monocular deprivation in adult mice alters visual acuity and single-unit activity. *Learn. Mem.* 14, 277–286.
- Frenkel, M.Y., and Bear, M.F. (2004). How monocular deprivation shifts ocular dominance in visual cortex of young mice. *Neuron* 44, 917–923.
- Froemke, R.C., and Dan, Y. (2002). Spike-timing-dependent synaptic modification induced by natural spike trains. *Nature* 416, 433–438.
- Galli, L., and Maffei, L. (1988). Spontaneous impulse activity of rat retinal ganglion cells in prenatal life. *Science* 242, 90–91.
- Gianfranceschi, L., Siciliano, R., Walls, J., Morales, B., Kirkwood, A., Huang, Z.J., Tonegawa, S., and Maffei, L. (2003). Visual cortex is rescued from the effects of dark rearing by overexpression of BDNF. *Proc. Natl. Acad. Sci. USA* 100, 12486–12491.

- Godement, P., Salaun, J., and Imbert, M. (1984). Prenatal and postnatal development of retinogeniculate and retinocollicular projections in the mouse. *J. Comp. Neurol.* *230*, 552–575.
- Goel, A., and Lee, H.K. (2007). Persistence of experience-induced homeostatic synaptic plasticity through adulthood in superficial layers of mouse visual cortex. *J. Neurosci.* *27*, 6692–6700.
- Gordon, J.A., and Stryker, M.P. (1996). Experience-dependent plasticity of binocular responses in the primary visual cortex of the mouse. *J. Neurosci.* *16*, 3274–3286.
- Grubb, M.S., Rossi, F.M., Changeux, J.P., and Thompson, I.D. (2003). Abnormal functional organization in the dorsal lateral geniculate nucleus of mice lacking the beta 2 subunit of the nicotinic acetylcholine receptor. *Neuron* *40*, 1161–1172.
- Guimaraes, A., Zaremba, S., and Hockfield, S. (1990). Molecular and morphological changes in the cat lateral geniculate nucleus and visual cortex induced by visual deprivation are revealed by monoclonal antibodies Cat-304 and Cat-301. *J. Neurosci.* *10*, 3014–3024.
- Hanover, J.L., Huang, Z.J., Tonegawa, S., and Stryker, M.P. (1999). Brain-derived neurotrophic factor overexpression induces precocious critical period in mouse visual cortex. *J. Neurosci.* *19*, RC40.
- He, H.Y., Hodos, W., and Quinlan, E.M. (2006). Visual deprivation reactivates rapid ocular dominance plasticity in adult visual cortex. *J. Neurosci.* *26*, 2951–2955.
- He, H.Y., Ray, B., Dennis, K., and Quinlan, E.M. (2007). Experience-dependent recovery of vision following chronic deprivation amblyopia. *Nat. Neurosci.* *10*, 1134–1136.
- Hensch, T.K. (2004). Critical period regulation. *Annu. Rev. Neurosci.* *27*, 549–579.
- Hensch, T.K. (2005). Critical period plasticity in local cortical circuits. *Nat. Rev. Neurosci.* *6*, 877–888.
- Hensch, T.K., and Stryker, M.P. (2004). Columnar architecture sculpted by GABA circuits in developing cat visual cortex. *Science* *303*, 1678–1681.
- Hensch, T.K., Fagiolini, M., Mataga, N., Stryker, M.P., Baekkeskov, S., and Kash, S.F. (1998a). Local GABA circuit control of experience-dependent plasticity in developing visual cortex. *Science* *282*, 1504–1508.
- Hensch, T.K., Gordon, J.A., Brandon, E.P., McKnight, G.S., Idzerda, R.L., and Stryker, M.P. (1998b). Comparison of plasticity in vivo and in vitro in the developing visual cortex of normal and protein kinase A  $\beta$ -deficient mice. *J. Neurosci.* *18*, 2108–2117.
- Heynen, A.J., Yoon, B.J., Liu, C.H., Chung, H.J., Hugarir, R.L., and Bear, M.F. (2003). Molecular mechanism for loss of visual cortical responsiveness following brief monocular deprivation. *Nat. Neurosci.* *6*, 854–862.
- Hofer, S.B., Mrsic-Flogel, T.D., Bonhoeffer, T., and Hubener, M. (2006). Prior experience enhances plasticity in adult visual cortex. *Nat. Neurosci.* *9*, 127–132.
- Holtmaat, A., Wilbrecht, L., Knott, G.W., Welker, E., and Svoboda, K. (2006). Experience-dependent and cell-type-specific spine growth in the neocortex. *Nature* *441*, 979–983.
- Hooks, B.M., and Chen, C. (2006). Distinct roles for spontaneous and visual activity in remodeling of the retinogeniculate synapse. *Neuron* *52*, 281–291.
- Horton, J.C., and Hocking, D.R. (1996). An adult-like pattern of ocular dominance columns in striate cortex of newborn monkeys prior to visual experience. *J. Neurosci.* *16*, 1791–1807.
- Huang, Z.J., Kirkwood, A., Pizzorusso, T., Porciatti, V., Morales, B., Bear, M.F., Maffei, L., and Tonegawa, S. (1999). BDNF regulates the maturation of inhibition and the critical period of plasticity in mouse visual cortex. *Cell* *98*, 739–755.
- Hubel, D.H. (1988). *Eye, Brain, and Vision* (New York: Scientific American Library: Distributed by W.H. Freeman).
- Hubel, D.H., and Wiesel, T.N. (1970). The period of susceptibility to the physiological effects of unilateral eye closure in kittens. *J. Physiol.* *206*, 419–436.
- Hubel, D.H., Wiesel, T.N., and LeVay, S. (1977). Plasticity of ocular dominance columns in monkey striate cortex. *Philos. Trans. R. Soc. Lond. B Biol. Sci.* *278*, 377–409.
- Huberman, A.D. (2007). Mechanisms of eye-specific visual circuit development. *Curr. Opin. Neurobiol.* *17*, 73–80.
- Huberman, A.D., Speer, C.M., and Chapman, B. (2006). Spontaneous retinal activity mediates development of ocular dominance columns and binocular receptive fields in v1. *Neuron* *52*, 247–254.
- Issa, N.P., Trachtenberg, J.T., Chapman, B., Zahs, K.R., and Stryker, M.P. (1999). The critical period for ocular dominance plasticity in the Ferret's visual cortex. *J. Neurosci.* *19*, 6965–6978.
- Jaubert-Miazza, L., Green, E., Lo, F.S., Bui, K., Mills, J., and Guido, W. (2005). Structural and functional composition of the developing retinogeniculate pathway in the mouse. *Vis. Neurosci.* *22*, 661–676.
- Jeffery, G. (1984). Retinal ganglion cell death and terminal field retraction in the developing rodent visual system. *Brain Res.* *315*, 81–96.
- Jones, K.R., Spear, P.D., and Tong, L. (1984). Critical periods for effects of monocular deprivation: differences between striate and extrastriate cortex. *J. Neurosci.* *4*, 2543–2552.
- Kantor, D.B., Chivatakarn, O., Peer, K.L., Oster, S.F., Inatani, M., Hansen, M.J., Flanagan, J.G., Yamaguchi, Y., Sretavan, D.W., Giger, R.J., and Kolodkin, A.L. (2004). Semaphorin 5A is a bifunctional axon guidance cue regulated by heparan and chondroitin sulfate proteoglycans. *Neuron* *44*, 961–975.
- Katagiri, H., Fagiolini, M., and Hensch, T.K. (2007). Optimization of somatic inhibition at critical period onset in mouse visual cortex. *Neuron* *53*, 805–812.
- Kind, P.C., Mitchell, D.E., Ahmed, B., Blakemore, C., Bonhoeffer, T., and Sengpiel, F. (2002). Correlated binocular activity guides recovery from monocular deprivation. *Nature* *416*, 430–433.
- Kirkwood, A., Silva, A., and Bear, M.F. (1997). Age-dependent decrease of synaptic plasticity in the neocortex of alphaCaMKII mutant mice. *Proc. Natl. Acad. Sci. USA* *94*, 3380–3383.
- Knudsen, E.I. (2002). Instructed learning in the auditory localization pathway of the barn owl. *Nature* *417*, 322–328.
- Knudsen, E.I. (2004). Sensitive periods in the development of the brain and behavior. *J. Cogn. Neurosci.* *16*, 1412–1425.
- Knudsen, E.I., and Brainard, M.S. (1991). Visual instruction of the neural map of auditory space in the developing optic tectum. *Science* *253*, 85–87.
- Lachance, P.E., and Chaudhuri, A. (2004). Microarray analysis of developmental plasticity in monkey primary visual cortex. *J. Neurochem.* *88*, 1455–1469.
- Landi, S., Cenni, M.C., Maffei, L., and Berardi, N. (2007). Environmental enrichment effects on development of retinal ganglion cell dendritic stratification require retinal BDNF. *PLoS ONE* *2*, e346. 10.1371/journal.pone.0000346.
- LeVay, S., Wiesel, T.N., and Hubel, D.H. (1980). The development of ocular dominance columns in normal and visually deprived monkeys. *J. Comp. Neurol.* *191*, 1–51.
- Lewis, T.L., and Maurer, D. (2005). Multiple sensitive periods in human visual development: evidence from visually deprived children. *Dev. Psychobiol.* *46*, 163–183.
- Li, Y., Fitzpatrick, D., and White, L.E. (2006). The development of direction selectivity in ferret visual cortex requires early visual experience. *Nat. Neurosci.* *9*, 676–681.

- Liao, D.S., Krahe, T.E., Prusky, G.T., Medina, A.E., and Ramoa, A.S. (2004). Recovery of cortical binocularity and orientation selectivity after the critical period for ocular dominance plasticity. *J. Neurophysiol.* 92, 2113–2121.
- Linden, D.C., Guillery, R.W., and Cucchiari, J. (1981). The dorsal lateral geniculate nucleus of the normal ferret and its postnatal development. *J. Comp. Neurol.* 203, 189–211.
- Lindenhöker, B.A., von der Ohe, C.G., and Knudsen, E.I. (2005). Anatomical traces of juvenile learning in the auditory system of adult barn owls. *Nat. Neurosci.* 8, 93–98.
- Linkenhöker, B.A., and Knudsen, E.I. (2002). Incremental training increases the plasticity of the auditory space map in adult barn owls. *Nature* 419, 293–296.
- Liu, X., Grishanin, R.N., Tolwani, R.J., Renteria, R.C., Xu, B., Reichardt, L.F., and Copenhagen, D.R. (2007). Brain-derived neurotrophic factor and TrkB modulate visual experience-dependent refinement of neuronal pathways in retina. *J. Neurosci.* 27, 7256–7267.
- Lu, H.C., Gonzalez, E., and Crair, M.C. (2001). Barrel cortex critical period plasticity is independent of changes in NMDA receptor subunit composition. *Neuron* 32, 619–634.
- Lu, W., and Constantine-Paton, M. (2004). Eye opening rapidly induces synaptic potentiation and refinement. *Neuron* 43, 237–249.
- Maffei, A., Nelson, S.B., and Turrigiano, G.G. (2004). Selective reconfiguration of layer 4 visual cortical circuitry by visual deprivation. *Nat. Neurosci.* 7, 1353–1359.
- Maffei, A., Nataraj, K., Nelson, S.B., and Turrigiano, G.G. (2006). Potentiation of cortical inhibition by visual deprivation. *Nature* 443, 81–84.
- Majdan, M., and Shatz, C.J. (2006). Effects of visual experience on activity-dependent gene regulation in cortex. *Nat. Neurosci.* 9, 650–659.
- Mataga, N., Mizuguchi, Y., and Hensch, T.K. (2004). Experience-dependent pruning of dendritic spines in visual cortex by tissue plasminogen activator. *Neuron* 44, 1031–1041.
- McGee, A.W., Yang, Y., Fischer, Q.S., Daw, N.W., and Strittmatter, S.M. (2005). Experience-driven plasticity of visual cortex limited by myelin and Nogo receptor. *Science* 309, 2222–2226.
- Meister, M., Wong, R.O., Baylor, D.A., and Shatz, C.J. (1991). Synchronous bursts of action potentials in ganglion cells of the developing mammalian retina. *Science* 252, 939–943.
- Meliza, C.D., and Dan, Y. (2006). Receptive-field modification in rat visual cortex induced by paired visual stimulation and single-cell spiking. *Neuron* 49, 183–189.
- Mitchell, D.E. (1988). The extent of visual recovery from early monocular or binocular visual deprivation in kittens. *J. Physiol.* 395, 639–660.
- Movshon, J.A. (1976). Reversal of the physiological effects of monocular deprivation in the kitten's visual cortex. *J. Physiol.* 261, 125–174.
- Mower, G.D. (1991). The effect of dark rearing on the time course of the critical period in cat visual cortex. *Brain Res. Dev. Brain Res.* 58, 151–158.
- Mrsic-Flogel, T.D., Hofer, S.B., Ohki, K., Reid, R.C., Bonhoeffer, T., and Hubener, M. (2007). Homeostatic regulation of eye-specific responses in visual cortex during ocular dominance plasticity. *Neuron* 54, 961–972.
- Muir-Robinson, G., Hwang, B.J., and Feller, M.B. (2002). Retinogeniculate axons undergo eye-specific segregation in the absence of eye-specific layers. *J. Neurosci.* 22, 5259–5264.
- Nassi, J.J., and Callaway, E.M. (2007). Specialized Circuits from Primary Visual Cortex to V2 and Area MT. *Neuron* 55, 799–808.
- Nedivi, E., Hevroni, D., Naot, D., Israeli, D., and Citri, Y. (1993). Numerous candidate plasticity-related genes revealed by differential cDNA cloning. *Nature* 363, 718–722.
- Nelson, S.B., Hempel, C., and Sugino, K. (2006). Probing the transcriptome of neuronal cell types. *Curr. Opin. Neurobiol.* 16, 571–576.
- Ohki, K., Chung, S., Ch'ng, Y.H., Kara, P., and Reid, R.C. (2005). Functional imaging with cellular resolution reveals precise micro-architecture in visual cortex. *Nature* 433, 597–603.
- Ohki, K., Chung, S., Kara, P., Hubener, M., Bonhoeffer, T., and Reid, R.C. (2006). Highly ordered arrangement of single neurons in orientation pinwheels. *Nature* 442, 925–928.
- Oray, S., Majewska, A., and Sur, M. (2004). Dendritic spine dynamics are regulated by monocular deprivation and extracellular matrix degradation. *Neuron* 44, 1021–1030.
- Ossipow, V., Pellissier, F., Schaad, O., and Ballivet, M. (2004). Gene expression analysis of the critical period in the visual cortex. *Mol. Cell. Neurosci.* 27, 70–83.
- Penn, A.A., Riquelme, P.A., Feller, M.B., and Shatz, C.J. (1998). Competition in retinogeniculate patterning driven by spontaneous activity. *Science* 279, 2108–2112.
- Pettigrew, J.D. (1974). The effect of visual experience on the development of stimulus specificity by kitten cortical neurones. *J. Physiol.* 237, 49–74.
- Pfeiffenberger, C., Cutforth, T., Woods, G., Yamada, J., Renteria, R.C., Copenhagen, D.R., Flanagan, J.G., and Feldheim, D.A. (2005). Ephrin-As and neural activity are required for eye-specific patterning during retinogeniculate mapping. *Nat. Neurosci.* 8, 1022–1027.
- Pfeiffenberger, C., Yamada, J., and Feldheim, D.A. (2006). Ephrin-As and patterned retinal activity act together in the development of topographic maps in the primary visual system. *J. Neurosci.* 26, 12873–12884.
- Pham, T.A., Impey, S., Storm, D.R., and Stryker, M.P. (1999). CRE-mediated gene transcription in neocortical neuronal plasticity during the developmental critical period. *Neuron* 22, 63–72.
- Pham, T.A., Rubenstein, J.L., Silva, A.J., Storm, D.R., and Stryker, M.P. (2001). The CRE/CREB pathway is transiently expressed in thalamic circuit development and contributes to refinement of retinogeniculate axons. *Neuron* 31, 409–420.
- Pizzorusso, T., Medini, P., Berardi, N., Chierzi, S., Fawcett, J.W., and Maffei, L. (2002). Reactivation of ocular dominance plasticity in the adult visual cortex. *Science* 298, 1248–1251.
- Pizzorusso, T., Medini, P., Landi, S., Baldini, S., Berardi, N., and Maffei, L. (2006). Structural and functional recovery from early monocular deprivation in adult rats. *Proc. Natl. Acad. Sci. USA* 103, 8517–8522.
- Porciatti, V., Pizzorusso, T., and Maffei, L. (1999). The visual physiology of the wild type mouse determined with pattern VEPs. *Vision Res.* 39, 3071–3081.
- Prasad, S.S., Kojic, L.Z., Li, P., Mitchell, D.E., Hachisuka, A., Sawada, J., Gu, Q., and Cynader, M.S. (2002). Gene expression patterns during enhanced periods of visual cortex plasticity. *Neuroscience* 111, 35–45.
- Putignano, E., Lonetti, G., Cancedda, L., Ratto, G., Costa, M., Maffei, L., and Pizzorusso, T. (2007). Developmental downregulation of histone posttranslational modifications regulates visual cortical plasticity. *Neuron* 53, 747–759.
- Rakic, P. (1976). Prenatal genesis of connections subserving ocular dominance in the rhesus monkey. *Nature* 261, 467–471.
- Rao, Y., Fischer, Q.S., Yang, Y., McKnight, G.S., LaRue, A., and Daw, N.W. (2004). Reduced ocular dominance plasticity and long-term potentiation in the developing visual cortex of protein kinase A RII alpha mutant mice. *Eur. J. Neurosci.* 20, 837–842.
- Ren, M., Yoshimura, Y., Takada, N., Horibe, S., and Komatsu, Y. (2007). Specialized inhibitory synaptic actions between nearby neocortical pyramidal neurons. *Science* 316, 758–761.
- Renger, J.J., Hartman, K.N., Tsuchimoto, Y., Yokoi, M., Nakanishi, S., and Hensch, T.K. (2002). Experience-dependent plasticity without

- long-term depression by type 2 metabotropic glutamate receptors in developing visual cortex. *Proc. Natl. Acad. Sci. USA* 99, 1041–1046.
- Rhoades, R.W., and Chalupa, L.M. (1978). Receptive field characteristics of superior colliculus neurons and visually guided behavior in dark-reared hamsters. *J. Comp. Neurol.* 177, 17–32.
- Sale, A., Maya Vetencourt, J.F., Medini, P., Cenni, M.C., Baroncelli, L., De Pasquale, R., and Maffei, L. (2007). Environmental enrichment in adulthood promotes amblyopia recovery through a reduction of intracortical inhibition. *Nat. Neurosci.* 10, 679–681.
- Sawtell, N.B., Frenkel, M.Y., Philpot, B.D., Nakazawa, K., Tonegawa, S., and Bear, M.F. (2003). NMDA receptor-dependent ocular dominance plasticity in adult visual cortex. *Neuron* 38, 977–985.
- Scheiman, M.M., Hertle, R.W., Beck, R.W., Edwards, A.R., Birch, E., Cotter, S.A., Crouch, E.R., Jr., Cruz, O.A., Davitt, B.V., Donahue, S., et al. (2005). Randomized trial of treatment of amblyopia in children aged 7 to 17 years. *Arch. Ophthalmol.* 123, 437–447.
- Schoups, A.A., Elliott, R.C., Friedman, W.J., and Black, I.B. (1995). NGF and BDNF are differentially modulated by visual experience in the developing geniculocortical pathway. *Brain Res. Dev. Brain Res.* 86, 326–334.
- Sengpiel, F., and Kind, P.C. (2002). The role of activity in development of the visual system. *Curr. Biol.* 12, R818–R826.
- Sengpiel, F., Stawinski, P., and Bonhoeffer, T. (1999). Influence of experience on orientation maps in cat visual cortex. *Nat. Neurosci.* 2, 727–732.
- Shatz, C.J. (1983). The prenatal development of the cat's retinogeniculate pathway. *J. Neurosci.* 3, 482–499.
- Shepherd, G.M., Stepanyants, A., Bureau, I., Chklovskii, D., and Svoboda, K. (2005). Geometric and functional organization of cortical circuits. *Nat. Neurosci.* 8, 782–790.
- Sherk, H., and Stryker, M.P. (1976). Quantitative study of cortical orientation selectivity in visually inexperienced kitten. *J. Neurophysiol.* 39, 63–70.
- Smith, S.L., and Trachtenberg, J.T. (2007). Experience-dependent binocular competition in the visual cortex begins at eye opening. *Nat. Neurosci.* 10, 370–375.
- Sretavan, D., and Shatz, C.J. (1984). Prenatal development of individual retinogeniculate axons during the period of segregation. *Nature* 308, 845–848.
- Sretavan, D.W., and Shatz, C.J. (1986). Prenatal development of retinal ganglion cell axons: segregation into eye-specific layers within the cat's lateral geniculate nucleus. *J. Neurosci.* 6, 234–251.
- Stevens, B., Allen, N.J., Vazquez, L.E., Howell, G.R., Christopherson, K.S., Nouri, N., Micheva, K.D., Mehalow, A., Huberman, A.D., Stafford, B., et al. (2007). The classical complement cascade mediates CNS synapse elimination. *Cell*, in press.
- Stryker, M.P., and Sherk, H. (1975). Modification of cortical orientation selectivity in the cat by restricted visual experience: a reexamination. *Science* 190, 904–906.
- Stryker, M.P., and Harris, W.A. (1986). Binocular impulse blockade prevents the formation of ocular dominance columns in cat visual cortex. *J. Neurosci.* 6, 2117–2133.
- Tagawa, Y., Kanold, P.O., Majdan, M., and Shatz, C.J. (2005). Multiple periods of functional ocular dominance plasticity in mouse visual cortex. *Nat. Neurosci.* 8, 380–388.
- Tian, N., and Copenhagen, D.R. (2003). Visual stimulation is required for refinement of ON and OFF pathways in postnatal retina. *Neuron* 39, 85–96.
- Tohmi, M., Kitaura, H., Komagata, S., Kudoh, M., and Shibuki, K. (2006). Enduring critical period plasticity visualized by transcranial flavoprotein imaging in mouse primary visual cortex. *J. Neurosci.* 26, 11775–11785.
- Trachtenberg, J.T., Trepel, C., and Stryker, M.P. (2000). Rapid extragranular plasticity in the absence of thalamocortical plasticity in the developing primary visual cortex. *Science* 287, 2029–2032.
- Tropea, D., Kreiman, G., Lyckman, A., Mukherjee, S., Yu, H., Horng, S., and Sur, M. (2006). Gene expression changes and molecular pathways mediating activity-dependent plasticity in visual cortex. *Nat. Neurosci.* 9, 660–668.
- Turrigiano, G.G., Leslie, K.R., Desai, N.S., Rutherford, L.C., and Nelson, S.B. (1998). Activity-dependent scaling of quantal amplitude in neocortical neurons. *Nature* 391, 892–896.
- Wang, K.H., Majewska, A., Schummers, J., Farley, B., Hu, C., Sur, M., and Tonegawa, S. (2006). In vivo two-photon imaging reveals a role of arc in enhancing orientation specificity in visual cortex. *Cell* 126, 389–402.
- White, L.E., Coppola, D.M., and Fitzpatrick, D. (2001). The contribution of sensory experience to the maturation of orientation selectivity in ferret visual cortex. *Nature* 411, 1049–1052.
- Wiesel, T.N., and Hubel, D.H. (1963). Single-Cell Responses in Striate Cortex of Kittens Deprived of Vision in One Eye. *J. Neurophysiol.* 26, 1003–1017.
- Xu, H.T., Pan, F., Yang, G., and Gan, W.B. (2007). Choice of cranial window type for in vivo imaging affects dendritic spine turnover in the cortex. *Nat. Neurosci.* 10, 549–551.
- Yoshimura, Y., Dantzker, J.L., and Callaway, E.M. (2005). Excitatory cortical neurons form fine-scale functional networks. *Nature* 433, 868–873.
- Zaremba, S., Guimaraes, A., Kalb, R.G., and Hockfield, S. (1989). Characterization of an activity-dependent, neuronal surface proteoglycan identified with monoclonal antibody Cat-301. *Neuron* 2, 1207–1219.
- Zarrinpar, A., and Callaway, E.M. (2006). Local connections to specific types of layer 6 neurons in the rat visual cortex. *J. Neurophysiol.* 95, 1751–1761.
- Ziburkus, J., and Guido, W. (2006). Loss of binocular responses and reduced retinal convergence during the period of retinogeniculate axon segregation. *J. Neurophysiol.* 96, 2775–2784.
- Zuo, Y., Yang, G., Kwon, E., and Gan, W.B. (2005). Long-term sensory deprivation prevents dendritic spine loss in primary somatosensory cortex. *Nature* 436, 261–265.