

CENTER OF GRAVITY - If g is the same for all elements of a body then the center of gravity (COG) is coincident with the center of mass

REQUIREMENTS FOR EQUILIBRIUM

$$\sum F_x = 0$$

$$\sum F_y = 0$$

$$\sum F_z = 0$$

$$\sum \tau_{\text{ANY POINT}} = 0$$

EXAMPLE I

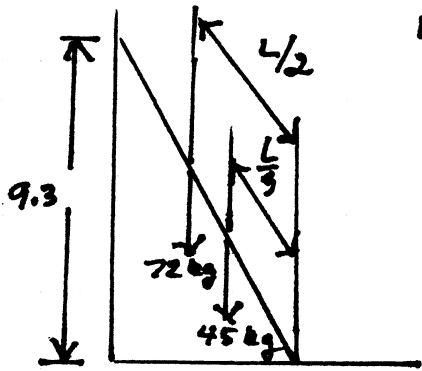

LADDER LENGTH = 12m = L

$$\sin \theta = \frac{9.3}{12} \quad \theta = 50.8^\circ$$

$$\sum F_y = 0 \quad F_v - (45 + 72)g = 0$$

$$F_v = 1150 \text{ N}$$

$$\sum F_x = 0$$

$$F_w - F_h \text{ (FRICTION FORCE)} = 0$$

$$F_w = F_h$$

$$\sum \tau_0 = 0$$

$$45g \left(\frac{L}{3}\right) \cos 50.8^\circ + 72g \left(\frac{L}{2}\right) \cos 50.8^\circ = 9.3 F_w$$

$$45(9.8)(4)(.632) + 72(9.8)(6)(.632) = 9.3 F_w$$

$$F_w = 410 \text{ N}$$

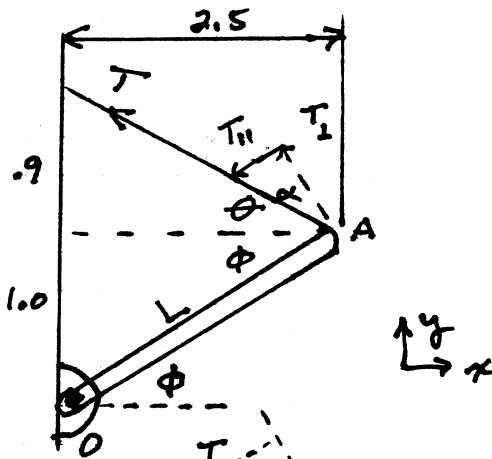

$$\begin{aligned} \tan \phi &= \frac{1.0}{2.5} & \phi &= 22^\circ \\ \tan \theta &= \frac{0.9}{2.5} & \theta &= 20^\circ \\ \alpha &= 90 - 20 - 22 = 48^\circ \end{aligned}$$

$$L = \sqrt{1^2 + 2.5^2} = 2.7$$

T_\perp is \perp to BAR OA
 T_H " " " " " "

$$\sum F_x = 0$$

$$F_H - T \cos 20 = 0$$

$$\sum F_y = 0$$

$$F_V + T \sin 20 - \underbrace{(85 + 430)g}_{5050} = 0$$

$$\begin{aligned} T_\perp &= T \cos \alpha \\ T_H &= T \sin \alpha \end{aligned}$$

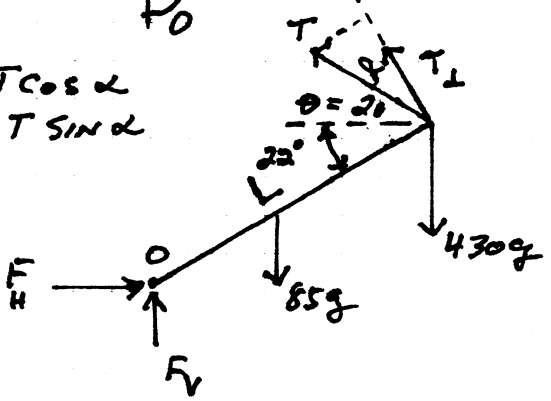

$$\sum \tau_0 = 0$$

$$\underbrace{T \cos 48 (2.7)}_{T_\perp} - \underbrace{85(9.8) \left(\frac{2.7}{2}\right) \cos 22}_{-1043} - \underbrace{430(9.8)(2.7) \cos 22}_{-10547} = 0$$

$$T = \frac{1043 + 10547}{2.7 \cos 48} = 6417 \text{ N}$$

$$F_H = T \cos 20 = 6030 \text{ N}$$

$$F_V = 5050 - 6417 \sin 20 = 2855 \text{ N}$$

13/5E

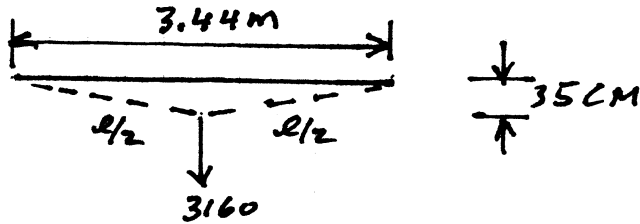

$$\tan \alpha = \frac{.35}{1.72} \quad \alpha = 11.5^\circ$$

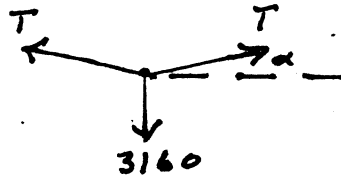

$$\sum F_x = 0 \quad T \cos \alpha - T \cos \alpha = 0$$

$$\sum F_y = 0 \quad -3160 + 2T \sin 11.5 = 0$$

$$T = \frac{3160}{2 \sin 11.5} = 7925 \text{ N}$$

13/7E

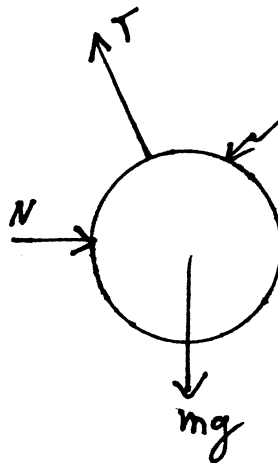
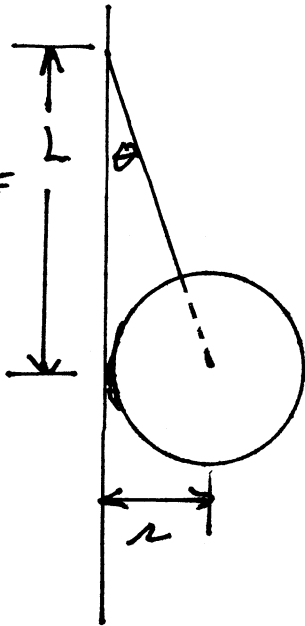

UNIFORM SPHERE OF RADIUS r & MASS m

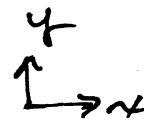

$$\sin \theta = \frac{r}{\sqrt{r^2 + L^2}}$$

$$\cos \theta = \frac{L}{\sqrt{r^2 + L^2}}$$

a) Find the Tension T in the Rope

$$\sum F_y = 0 \quad T \cos \theta - mg = 0 \quad T = \frac{mg}{\cos \theta}$$

$$\sum F_x = 0 \quad N - T \sin \theta = 0$$

FROM GEOMETRY $\cos \theta = \frac{L}{\sqrt{r^2 + L^2}} \Rightarrow T = mg \left(\frac{\sqrt{r^2 + L^2}}{L} \right)$

b) Find the Force on the Wall N

$$N = T \sin \theta = T \left(\frac{r}{\sqrt{r^2 + L^2}} \right) = mg \frac{\sqrt{r^2 + L^2}}{L} \times \frac{r}{\sqrt{r^2 + L^2}} = \frac{mg r}{L}$$

13/17 P

FIND F
FOR EQUILIB.

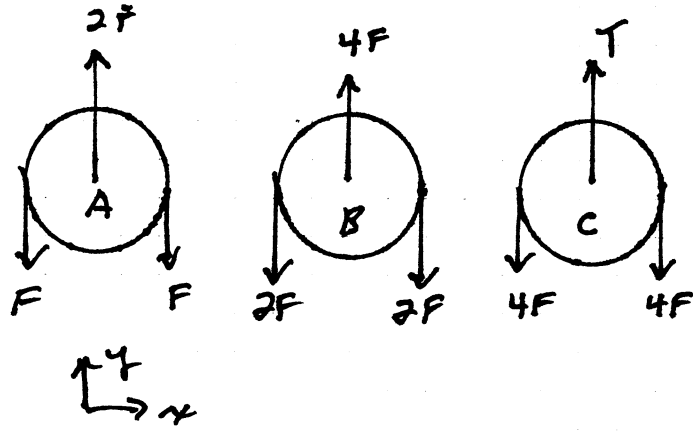
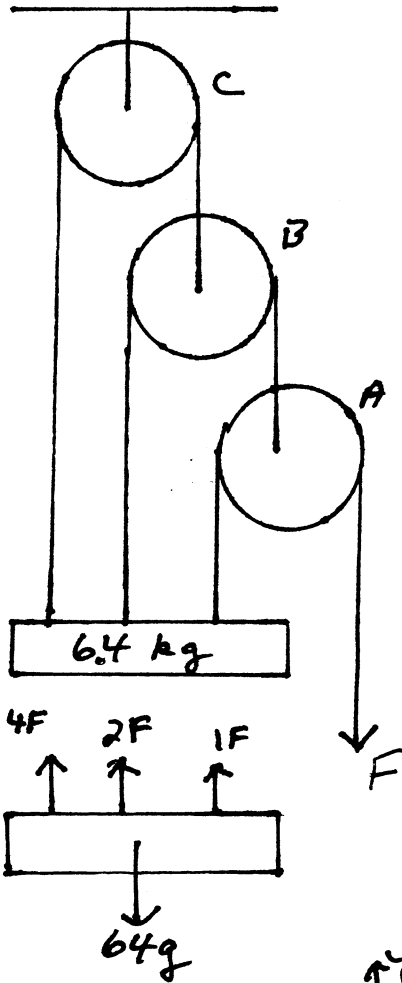

FOR THE 64 kg BLOCK $\sum F_y = 0$

$$F + 2F + 4F = 64g$$

$$F = \frac{64g}{7} = 8.96 \text{ N}$$

$$T = 8F = 8(8.96) = 71.7 \text{ N}$$

Find F_H, F_V and
FOR EQUILIB.

13/19

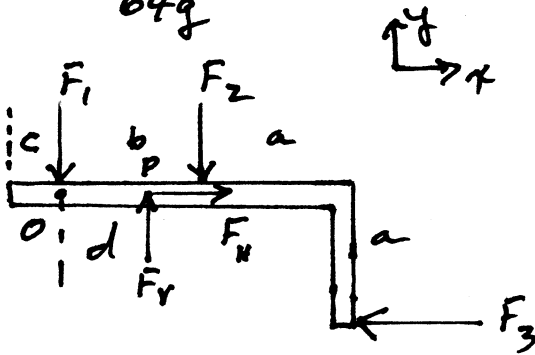

- $a = 2$ $F_1 = 20$
- $b = 3$ $F_2 = 10$
- $c = 1$ $F_3 = 5$

$$\sum F_x = 0 \quad F_H - F_3 = 0 \quad F_H = F_3 = 5 \text{ N}$$

$$\sum F_y = 0 \quad F_V - F_1 - F_2 = 0 \quad F_V = F_1 + F_2 = 10 + 20 = 30$$

$\sum \tau = 0$

$$\sum \tau_o = 0$$

$$+ F_V(d) - F_2(b) - F_3(a) = 0$$

$$d = \frac{F_2 b + F_3 a}{F_V} = \frac{10(3) + 5(2)}{30} = \frac{40}{30} = 1.33 \text{ m}$$

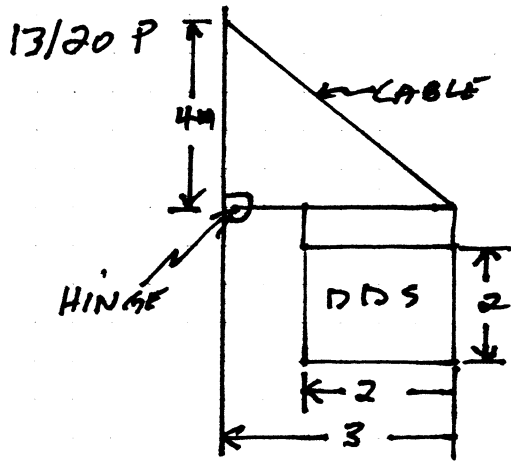

a) find the Tension T_1

b) find the REACTIONS AT THE PIN JOINT T_2 & T_3

$$\tan \theta = \frac{4}{3} \quad \theta = 53^\circ$$

$$\sum F_x = 0 \quad T_3 - T_1 \cos \theta = 0$$

$$\sum F_y = 0 \quad T_2 + T_1 \sin \theta - 50g = 0$$

$$T_2 + T_1 \sin 53 = 490$$

$$\sum \tau_o = 0 \quad T_1 \sin \theta (3) - mg(2) = 0$$

$$T_1 = \frac{50(9.8)2}{3 \sin 53} = 410 \text{ N}$$

$$T_2 = -T_1 \sin 53 + 490 = 247 \text{ N}$$

$$T_3 = T_1 \cos 53 = 247 \text{ N}$$

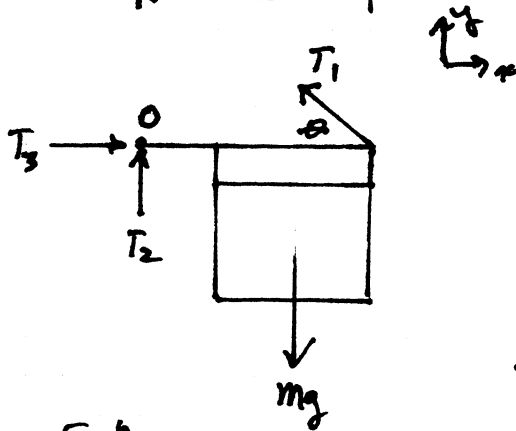

$$m_{\text{block}} = 50 \text{ kg}$$

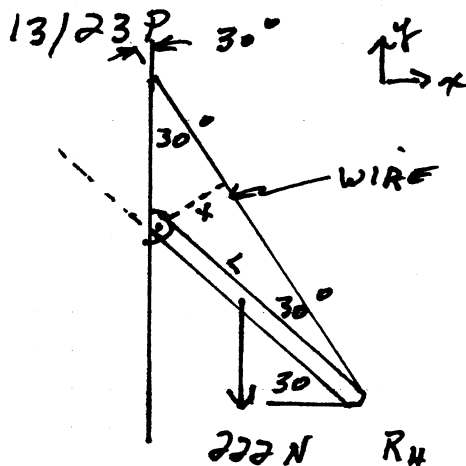

$$\sum F_x = 0 \quad R_H - T \sin 30 = 0$$

$$\sum F_y = 0 \quad R_V + T \cos 30 = 222$$

$$\sum \tau_{\text{HINGE}} = 0$$

$$+Tx - 222\left(\frac{L}{2} \cos 30\right) = 0$$

$$+T\left(\frac{L}{2}\right) - 222\left(\frac{L}{2}\right) \cos 30 = 0$$

$$T = 222 \cos 30 = 192 \text{ N}$$

$$R_V = 222 - T \cos 30 = 56 \text{ N}$$

$$R_H = T \sin 30 = 96 \text{ N}$$

$$x = L \sin 30 = \frac{L}{2}$$

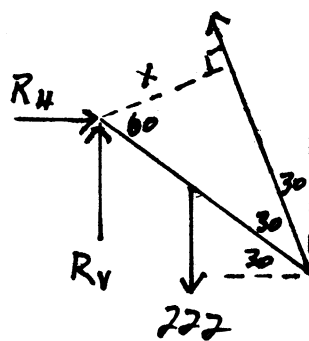

13/25P

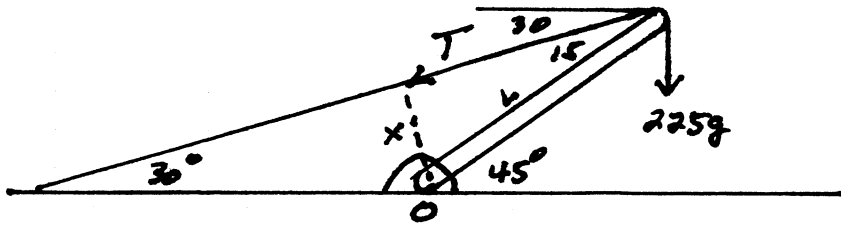

Mass = 45g
STRUT

$$x = L \sin 15$$

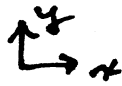

$$\sum F_x = 0 \quad R_H - T \cos 30 = 0$$

$$\sum F_y = 0 \quad R_V - (45 + 225)g - T \sin 30 = 0$$

$$\sum \tau_0 = 0$$

$$-45g \left(\frac{L}{2} \cos 45 \right) - 225g (L \cos 45) + T x = 0$$

$$441 L (.707) + 2205 L (.707) = T L (.259)$$

$$1564 + 15594 = .259 T L$$

$$T = 6622 \text{ N}$$

$$R_H = 6622 \cos 30 = 5735 \text{ N}$$

$$R_V = 270g + 6622 \sin 30 = 2646 + 3311 = 5960 \text{ N}$$

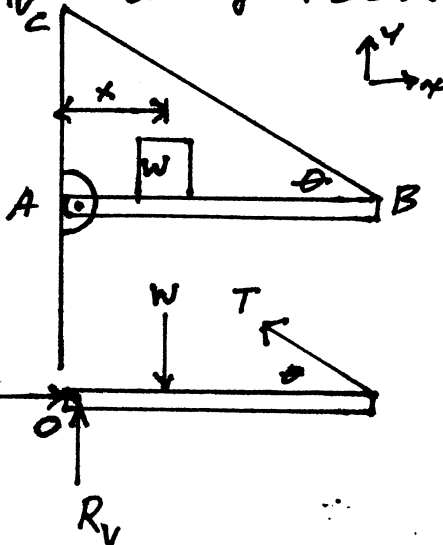

$$\sum F_x = 0 \quad R_H = T \cos \theta$$

$$\sum F_y = 0 \quad R_V + T \sin \theta = W$$

$$\sum \tau_0 = 0$$

$$-Wx + T \sin \theta L = 0$$

$$T = \frac{Wx}{L \sin \theta}$$

$$R_H = T \cos \theta = \frac{Wx \cos \theta}{L \sin \theta} = \frac{Wx}{L \tan \theta}$$

$$R_V = W - \frac{Wx \sin \theta}{L \sin \theta} = W \left(1 - \frac{x}{L} \right)$$

13/28

find

$R_H(x), R_V(x)$

13/29

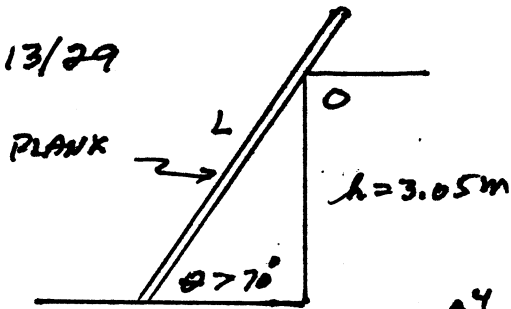

L = 6.1 m

W = 445 N ~~311~~ - 7find μ_s FOR THE PLANK

$$d = \frac{h}{\tan \theta}$$

$$\sum F_x = 0 \quad f - F \sin \theta = 0 \quad (1)$$

$$\sum F_y = 0 \quad F \cos \theta - W + N = 0 \quad (2)$$

$$\sum \tau = 0$$

$$-Nd + fh + W(d - \frac{L}{2} \cos \theta) = 0 \quad (3)$$

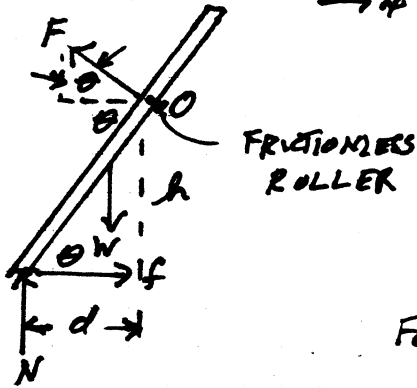
FOR $\theta = 70^\circ$ WE PROCEED AS FOLLOWS:

Putting (2) into (1) i.e.

$$\text{Putting } F = \frac{W - N}{\cos \theta} \text{ into (1) } f = \frac{(W - N) \sin \theta}{\cos \theta} = \frac{W - N}{\tan \theta} \quad (5)$$

SUBSTITUTING FOR f INTO (3)

$$N = \left(\frac{d - (\frac{L}{2}) \cos \theta + h \tan \theta}{d + h \tan \theta} \right) W$$

$$\frac{1}{f} d = \frac{h}{\tan \theta} \quad N = W \left(1 - \frac{L}{2h} \cos^2 \theta \sin \theta \right) \quad (4)$$

SUBSTITUTING (4) INTO (5)

$$f = \frac{WL}{2h} \sin^2 \theta \cos \theta$$

$$\mu = \frac{f}{N} = \frac{(WL/2h) \sin^2 \theta \cos \theta}{W \left(1 - \frac{L}{2h} \cos^2 \theta \sin \theta \right)}$$

$$\mu_s = \frac{L \sin^2 \theta \cos \theta}{2h - L \sin \theta \cos^2 \theta}$$

$$\mu = \frac{6.1 (\sin^2 70 \cos 70)}{2(3.05) - 6.1 \sin 70 \cos^2 70} = 0.34$$

PHYSICS 111 SAMPLE QUIZ III

1. A 2-kg object is acted upon by a single force in the x direction in a manner described by the graph shown. The momentum acquired by the object is:

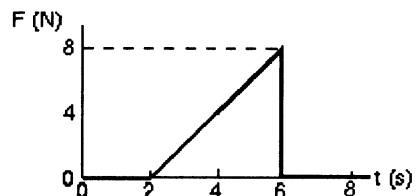

- A) 16 N · s
B) 30 N · s
C) 32 N · s
D) 40 N · s
E) 48 N · s
2. A 5-ton freight car, moving at 4 mph, collides and couples with an 8-ton freight car, which was initially at rest. The common final speed of these two cars is:
- A) 1 mph
B) 1.31 mph
C) 1.54 mph
D) 2.5 mph
E) 4 mph
3. Blocks A and B are moving toward each other. A has a mass of 2.0 kg and a velocity of 50 m/s, while B has a mass of 4.0 kg and a velocity of -25 m/s. They suffer a completely inelastic collision. The kinetic energy dissipated during the collision is:
- A) 0
B) 2500 J
C) 5000 J
D) 3750 J
E) 10000 J

4. Sphere A has mass m and is moving with velocity v . It makes a head-on elastic collision with a stationary sphere B of mass $2m$. After the collision their speeds (v_A , v_B) are:
- A) $-2v/3$, $v/3$
 - B) $-v$, v
 - C) none of these
 - D) $-v/3$, $2v/3$
 - E) 0 , $v/2$
5. A very massive object traveling at 10 m/s strikes a light object, initially at rest, and the light object moves off in the direction of travel of the heavy object. Its speed is:
- A) 5.0 m/s
 - B) 10 m/s
 - C) 15 m/s
 - D) 20 m/s
 - E) Can't tell from the information given.
6. If a wheel is turning at 3.0 rad/s , the time it takes to complete one revolution is about:
- A) 0.33 s
 - B) 0.67 s
 - C) 1.0 s
 - D) 1.3 s
 - E) 2.1 s
7. A wheel starts from rest and has an angular acceleration of 4.0 rad/s^2 . The time it takes to make 10 revolutions is:
- A) 0.50 s
 - B) 0.71 s
 - C) 1.4 s
 - D) 5.6 s
 - E) 3.1 s

8. A flywheel of diameter 4.0 ft has a constant angular acceleration of 5.0 rad/s^2 . The tangential acceleration of a point on its rim is:
- A) 10 rad/s^2
 B) 20 rad/s^2
 C) 5 ft/s^2
 D) 10 ft/s^2
 E) 20 ft/s^2
9. The rotational inertia of a disk about its axis is $0.70 \text{ kg}\cdot\text{m}^2$. When a 2.0 kg weight is added to its rim, 0.40 m from the axis, the rotational inertia becomes:
- A) $0.38 \text{ kg}\cdot\text{m}^2$
 B) $0.54 \text{ kg}\cdot\text{m}^2$
 C) $0.70 \text{ kg}\cdot\text{m}^2$
 D) $0.86 \text{ kg}\cdot\text{m}^2$
 E) $1.0 \text{ kg}\cdot\text{m}^2$
10. A rod is pivoted about its center. A 5 N force is applied 4 m from the pivot and another 5 N force is applied 2 m from the pivot, as shown. The magnitude of the total torque about the pivot (in $\text{N}\cdot\text{m}$) is:

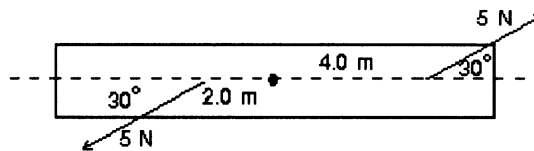

- A) 0
 B) 15
 C) 8.7
 D) 5
 E) 26

11. Possible units of angular momentum are:
- A) $\text{kg} \cdot \text{m}^2/\text{s}^2$
 - B) $\text{kg} \cdot \text{m}/\text{s}$
 - C) $\text{kg} \cdot \text{m}^2/\text{s}$
 - D) none of these
 - E) $\text{kg} \cdot \text{m}/\text{s}^2$
12. A single force acts on a particle situated on the positive x axis. The torque about the origin is in the negative z direction. The force might be:
- A) in the negative y direction
 - B) in the positive z direction
 - C) in the positive y direction
 - D) in the negative x direction
 - E) in the positive x direction
13. A man, with his arms at his sides, is spinning on a light frictionless turntable. When he extends his arms:
- A) his angular velocity increases
 - B) his angular velocity remains the same
 - C) his rotational inertia decreases
 - D) his rotational kinetic energy increases
 - E) his angular momentum remains the same
14. A playground merry-go-round has a radius of 3.0 m and a rotational inertia of $600 \text{ kg} \cdot \text{m}^2$. It is initially spinning at 0.80 rad/s when a 20-kg child crawls from the center to the rim. When the child reaches the rim the angular velocity of the merry-go-round is:
- A) 0.61 rad/s
 - B) 0.73 rad/s
 - C) 0.80 rad/s
 - D) 0.89 rad/s
 - E) 1.1 rad/s

15. An object M , on the end of a string, moves in a circle on a horizontal frictionless table as shown. As the string is slowly pulled through a small hole in the table:

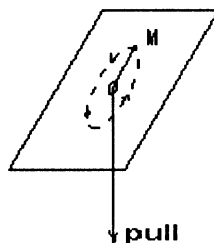

- A) the angular momentum of M decreases
- B) the kinetic energy of M decreases
- C) the angular momentum of M remains constant
- D) the kinetic energy of M remains constant
- E) none of the above

Answer Key

1. A
2. C
3. D
4. D
5. D
6. E
7. D
8. D
9. E
10. B
11. C
12. A
13. E
14. A
15. C