

Laboratory Manual and Supplementary  
Notes

ECE 429: Communication Laboratory

Version 1.0

Dr. Joseph Frank  
Dr. Sol Rosenstark

Department of Electrical and Computer Engineering  
New Jersey Institute of Technology  
Newark, New Jersey

© 2003  
New Jersey Institute of Technology  
All rights reserved

# Contents

<b>Acknowledgements</b>	<b>iii</b>
<b>Introduction and Tutorial Material</b>	<b>1</b>
Introduction . . . . .	1
The Spectrum Analyzer . . . . .	1
Laboratory Work . . . . .	2
<b>Experiment 1 — Circuits and Signals in the Time and Frequency Domains</b>	<b>5</b>
Introduction . . . . .	5
References . . . . .	5
The RC Integrating Circuit – A Tutorial . . . . .	5
The RC Integrating Circuit – The Experiment . . . . .	7
The RC Differentiating Circuit . . . . .	8
The RC Differentiating Circuit – The Experiment . . . . .	11
Determination of Circuit Elements Using Square Wave Testing . . . . .	11
Propagation and Reflection of Pulses on a Cable . . . . .	12
Observation of the Spectrum of Signals . . . . .	13
The Report . . . . .	13
<b>Experiment 2 — Frequency Modulation and Spectra of FM Signals</b>	<b>14</b>
Frequency Modulation — A Tutorial . . . . .	14
Frequency Modulation — Part 1 . . . . .	17
Frequency Modulation — Part 2 . . . . .	18
Frequency Modulation — Part 3 . . . . .	19
Frequency Modulation — Part 4 . . . . .	19
Frequency Modulation — Part 5 . . . . .	19
<b>Experiment 3 — Amplitude Modulation and Spectra of AM Signals</b>	<b>21</b>
Amplitude Modulation — A Tutorial . . . . .	21

Generation of AM Signals . . . . .	23
The Experiment . . . . .	25
<b>Experiment 4 — Distortion Analysis</b>	<b>28</b>
Distortion Analysis — A Tutorial . . . . .	28
The Experiment . . . . .	31
<b>Experiment 5 — Measurements on Noise</b>	<b>32</b>
Introduction . . . . .	32
Noise — A Tutorial . . . . .	32
The Experiment . . . . .	33

# Acknowledgement

Experiments 1 and 2 are based on experiments originally written by Dr. Jacob Klapper.

# Introduction and Tutorial Material

## Introduction

The purpose of this laboratory course is to give the student an opportunity to do experiments relating to the topics studied in the communication systems and related courses. The student will have the opportunity to observe AM and FM signals in the time and frequency domains and to learn about the generation and detection of modulated waveforms. The student also will be afforded a chance to learn about measurements of distortion and noise as well as get a familiarity with some instruments not previously encountered such as spectrum analyzers, audio analyzers and noise generators.

The work in this laboratory will stress and agreement between theory and measurement. It is very important that the student have a clear idea of what to expect from each measurement, in order to immediately determine if things are working correctly. The student should be constantly be wondering – is this reasonable, both qualitatively and quantitatively? If the lab observations are not in reasonable agreement with what was expected, then further observation or preparatory analysis are in order to determine the source of the discrepancy. There is no point in taking data and going home to write a lab report only to find out that the data is meaningless because there was on error in the lab set-up or procedure.

It is very important to get in the habit of working in a logical, scientific manner. The laboratory experience is valuable for showing us the small discrepancies between theory and practice, *but there must be reasonable agreement between what we observe and what we expect to observe.*

## The Spectrum Analyzer

The spectrum analyzer is an important and useful tool for examining signals in the frequency domain. As it is an instrument with which the student may

not be familiar, a brief explanation will be given here, and part of the first lab session will be devoted to becoming familiar with this instrument. For a more detailed explanation of this instrument see the manual which is available in the stockroom.

The spectrum analyzer can be thought of as a band pass filter whose center frequency is varied linearly over a range of frequencies. The center frequency of the filter is plotted on the horizontal axis and the output of the filter is plotted on the vertical axis. The filter must be swept over the frequency range slowly enough so we obtain the steady state filter output. The internal circuitry of the analyzer automatically changes the sweep rate as the filter's bandwidth is changed to insure this condition is met. There is a default setting for the filter bandwidth, but it can be changed using the front panel controls. A wide bandwidth allows a more rapid sweep, but a narrow bandwidth is necessary to resolve closely spaced signals. Suppose for example that we wanted to observe a signal that consisted of two sine waves, one at 500 kHz and one at 505 kHz. If we had a filter bandwidth of 30 kHz we would not be able to resolve them as two separate signals, they would appear as one. However, if we reduced the bandwidth to 1 kHz we would be able to resolve them into two distinct signals, and be able to measure their frequency separation and their individual amplitudes.

In operating the spectrum analyzer there are three principal parameters that the operator should set. These are, center frequency, span and amplitude. The center frequency setting determines the frequency that corresponds to the middle of the screen. The calibration of this setting is not very accurate on the older analyzers, but this is not a serious problem in using the analyzer as we are usually interested in frequency differences. The span determines the range of frequencies from one side of the screen to the other. For example, if we set the center frequency to 10 MHz and the span to 2 MHz, the screen would cover the range 9 MHz to 11 MHz and any signals in that frequency range applied to the input would be seen on the screen. The amplitude can be set to either the log or linear mode. The log mode is useful for looking at two or more signals that have large differences in amplitude. In this mode the scale is calibrated in dB/division, with a given reference value corresponding to the top line. In the linear mode, which is good for observing small differences in amplitude, the top line can be set to correspond to a given voltage.

## Laboratory Work

To get some experience in working with the spectrum analyzer, the first thing to observe is a single sine wave. Connect the signal generator both to the scope and the spectrum analyzer using a T connector. Adjust the generator so the signal frequency is 10 MHz and the peak to peak amplitude is 0.2 volts. Adjust the center frequency of the spectrum analyzer to 10 MHz, the span to 10 MHz and

the signal amplitude so the reference level is 0 dBm and the vertical calibration is 10 dB/div. You should see a line approximately in the middle of the screen. Vary the frequency of the generator and check that the line moves 1 box/MHz.

It is worthwhile to note that the spectrum analyzer is calibrated in dBm. The dBm is a unit of power which is defined as,

$$P_{dBm} = 10 \log_{10} \frac{P}{1 \text{ milliwatt}}$$

The input resistance of the spectrum analyzer is  $50 \Omega$ . A signal that has an amplitude of 0.1 volt has an rms value of 0.0707 volts and a peak to peak voltage of 0.2 volts. Its power is calculated from its rms value below

$$P = \frac{(0.0707)^2}{50} = .0001 \text{ watts} = 0.1 \text{ milliwatts}$$

When this power is referred to 1 milliwatt, we get

$$P_{dBm} = 10 \log_{10} \frac{0.1}{1} = -10 \text{ dBm}$$

If the spectrum analyzer amplitude settings are adjusted so that the reference is 0 dBm and the vertical scale is at 10 dB/div, then the height of the line on the screen should be one box below the top of the screen. If you turn the attenuator knob on the generator, the height of the line on the screen should decrease one box for each additional 10 dB of attenuation. If you change the amplitude mode to linear, then you should be able to measure the rms value of the signal. In this case, the original 0.2 volt peak to peak signal should measure 70.7 millivolts.

Now try to repeat this measurement using a 1 MHz signal. Adjust the center frequency and span to appropriate values. You will probably notice a line on the screen that corresponds to what the analyzer thinks is zero frequency. This is the zero marker.

**When measuring low frequency signals you have to be careful not to confuse the zero marker with the signal.** This is a very common error. It is very easy to tell the difference. If you make a change in the amplitude or frequency of the signal and the line does not move, then it is the zero marker. Another quick check is to just remove the input cable from the spectrum analyzer and see if the line disappears.

Having mastered the observation of a single sinusoidal signal on the spectrum analyzer we are ready to try the observation of closely spaced sinusoidal signals. An easy way to obtain three closely spaced sinusoidal signals is to use an amplitude modulated signal. Use the Wavetek generator with internal AM modulation to produce an AM signal with a 5 MHz carrier frequency modulated by a 10 kHz tone with a modulation index of 0.5. The equation of this signal is

$$x(t) = (1 + 0.5 \cos 2\pi 10^4 t) \cos 2\pi 5 \times 10^6 t$$

Before you proceed you should sketch the waveform of  $x(t)$  to get an idea of how it should appear on an oscilloscope. When displaying this signal, it is helpful to use the modulating signal on the external sync terminal of the oscilloscope to obtain a steady picture.

To see what kind of spectrum the above will produce, we use trigonometric identities in the above expression, to obtain

$$x(t) = \cos 2\pi 5 \times 10^6 t + 0.25 \cos 2\pi(5 \times 10^6 + 10^4)t + 0.25 \cos 2\pi(5 \times 10^6 - 10^4)t$$

It is now clear that on the spectrum analyzer you should see 3 lines separated by 10KHz, with the outer two lines having an amplitude  $\frac{1}{4}$  of the amplitude of the center line. On the log scale this corresponds to a 12 dB difference in amplitude.

What are sensible settings for center frequency and span to observe the amplitude modulated wave?

Try slowly reducing the modulating frequency – noting that the lines come closer together.

What is the closest spacing of the lines that allows you to see them as individual lines?

Reduce the resolution bandwidth of the spectrum analyzer when trying to resolve closely spaced signals.

There are many other interesting and useful features of the spectrum analyzer that you can investigate. Using the manual that is available in the stockroom is very helpful. One especially useful feature is the system of markers.



# Experiment 1 — Circuits and Signals in the Time and Frequency Domains

## Introduction

The description of signals used in communication systems, and the performance of circuits used in these systems can be described in either the time domain or the frequency domain. The domain to use is the one that is convenient for the specific situation. There is a mathematical relationship between the description in the two domains which is given by the Fourier transform or, in the case of periodic functions, by the Fourier series. Thus, if we have a description of a signal in one domain we can calculate its description in the other domain. In this experiment we will look at some signals in the time domain using the oscilloscope and in the frequency domain using the spectrum analyzer. This will help the student develop a “feel” for the relationship between these domains.

## References

References to all the material covered in this experiment can be found in the textbooks you used in ECE 231, ECE 232, ECE 368 and in ECE 421. This material is covered in a large number of texts on circuit and systems analysis, and is also usually covered in the introductory chapters of communication system texts.

## The RC Integrating Circuit — A Tutorial

The RC integrating circuit shown in figure 1.1a is also very simple low-pass filter. Its performance parameters can be established by performing measurements in

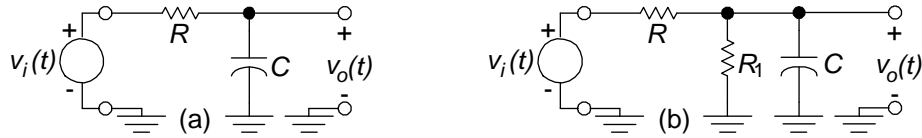

Figure 1.1: The basic RC integrating circuit (a) and a variant thereof (b).

either the time or the frequency domains. We will now examine the theoretical basis for these laboratory observations.

If the input to the integrating circuit is a step voltage, namely  $v_i(t) = Vu(t)$ , then the output  $v_o(t)$  is the step response of the circuit. The step response of this circuit is well known to be

$$v_o(t) = V \left( 1 - e^{-t/RC} \right) u(t) \quad (1.1)$$

A sketch of this waveform will reveal that in  $RC$  seconds the voltage reaches within 36.8% of its final value. It is the  $RC$  time constant

$$\tau = RC \quad (1.2)$$

that determines the speed of response of this circuit.

When the signal approaches  $V$  volts it is very difficult to determine accurately how close it has come to the steady state since the signal changes very slowly in that region. It is therefore best to perform time observations on the waveform substantially away from the steady state values. One of the methods of establishing experimentally the time constant of this is to measure the rise time,  $t_r$ , of its step response. By definition the *rise time* is *the time required for the step response to go from 10% to 90% of its final value*.

To determine the rise time of the RC integrating circuit, we evaluate (1.1) at the two desired values, subtract the two and discover that

$$t_r = 2.2RC \quad (1.3)$$

We can analyze the integrator circuit for the AC steady state and obtain its transfer function as a function of frequency. When that is done we find that

$$H(f) = \frac{V_o(f)}{V_i(f)} = \frac{1}{1 + jf/f_h} \quad (1.4)$$

This equation tells us that the integrator is also a low-pass filter. The magnitude of  $H(f)$  is unity at frequencies at which  $f \ll f_h$ . The magnitude of the transfer function decreases as  $f$  increases. At  $f = f_h$ ,  $|H(f)| = 1/\sqrt{2}$ , consequently  $f_h$  is considered the half power, or 3 dB, frequency of the circuit. This frequency is given by

$$f_h = \frac{1}{2\pi RC} \quad (1.5)$$

Multiplying (1.3) by (1.5) gives the result

$$f_h = \frac{0.35}{t_r} \quad (1.6)$$

The last relation is very interesting. It tells us that the 3 dB bandwidth of this circuit is inversely related to its rise time. Short rise times require large bandwidths. Narrow bandwidths lead to long rise times. We might say that fast circuits require substantial bandwidth.

We can measure the rise time of the integrator by putting in place of  $v_i(t)$  a square wave and observe the output  $v_o(t)$  on an oscilloscope. The frequency of the square wave has to be low enough so that we can see the final steady state values of the pulse train when observing  $v_o(t)$ , but not so low that it is difficult to discern the rise time of the square wave. The rise time will then determine the 3 dB frequency of the circuit.

Another test that can be performed is to put a sine-wave generator in place of  $v_i(t)$  and simultaneously observing the input  $v_i(t)$  and the output  $v_o(t)$  on an oscilloscope. The frequency of the sine wave is then varied to permit the measurement of the transfer function of (1.4). At the frequency  $f_h$  a 3 dB reduction in transfer function should be observed. That means that the magnitude of the transfer function should be reduced to  $1/\sqrt{2}$  and the phase shift should be  $-45^\circ$ .

Now that the cutoff frequency  $f_h$  and the rise time  $t_r$  have been measured, the relationship (1.6) can be verified.

**In your report answers the questions below.**

1. Derive (1.1) using Laplace transforms.
2. Determine how (1.3) was derived from (1.1).
3. Derive (1.4) using basic AC steady state analysis and show that (1.5) is the correct expression for  $f_h$ .
4. Derive the equivalent of (1.1 – 1.6) for the circuit shown in figure 1.1b.

## The RC Integrating Circuit – The Experiment

Construct an RC integrating circuit of the type shown in figure 1.1a. Apply a square wave to the input and sketch both input and output waveforms for the three conditions below.

$$(a) \quad \tau \ll T \quad (b) \quad \tau \approx T \quad (c) \quad \tau \gg T \quad (1.7)$$

Choose the value of  $\tau$  so you will be able to do this using square waves having frequencies that are easy to work with, those in the range 100 Hz – 100 kHz.

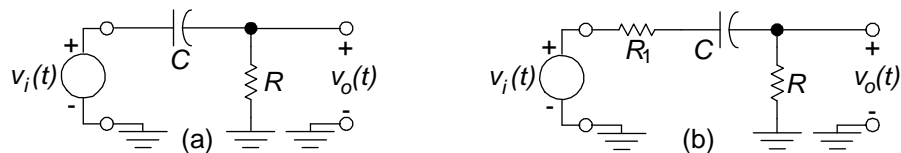

Figure 1.2: The basic RC differentiating circuit (a) and a variant thereof (b).

**Note:** The sketching should be done with great care and should include numerical values on amplitude and time scales.

Case (c) corresponds to conditions for approximate integration – the output waveform should be a good approximation to a triangular wave. The output is related to the input by

$$v_o(t) = \frac{1}{RC} \int v_i(t) dt \quad (1.8)$$

Using this idea, calculate the peak to peak amplitude you expect to observe for the triangular wave knowing  $R$ ,  $C$  and the period  $T$  for the square wave. Compare with the measured value.

Choose a convenient frequency for the square wave input and measure the rise time of the output.

Using a sinusoidal signal, take data to plot the magnitude of the transfer function of your circuit. Plot  $20 \log_{10}[V_o/V_{in}]$  (which is the gain of the circuit expressed in dB) as a function of frequency using semi-log paper. Find the frequency  $f_h$  for which the gain is -3 dB. Your plot should cover the frequency range  $f_h/10$  to  $50f_h$

The theoretical relationship between  $t_r$  and  $f_h$  is given in (1.6). Using your measured values for  $f_h$  and  $t_r$  check how closely your results agree with the theoretical value.

## The RC Differentiating Circuit

The RC differentiating circuit shown in figure 1.2a is also a very simple high-pass filter. In this case too, the performance of this circuit can be established by performing measurements in either the time or the frequency domains. The theoretical basis for these laboratory observations will now be presented.

If the input to the differentiating circuit is a step voltage, namely  $v_i(t) = Vu(t)$ , then the step response of this circuit is well known to be

$$v_o(t) = Ve^{-t/RC}u(t) \quad (1.9)$$

It is worthwhile to sketch this waveform and to observe that in  $RC$  seconds the voltage reaches within 36.8% of its final zero value. As before, the  $RC$  time constant of (1.2) determines the speed of response of this circuit.

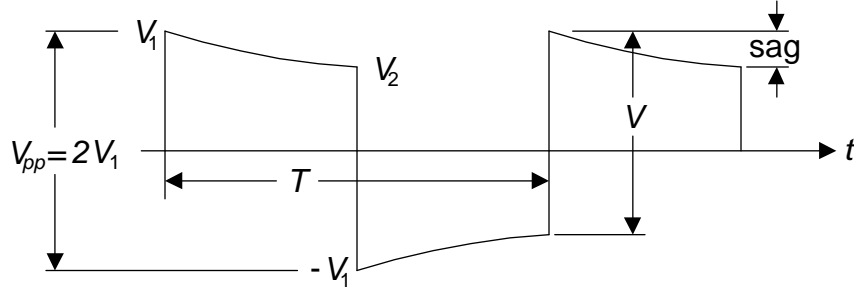

Figure 1.3: Output of the differentiating circuit when the input is a square wave.

If the input to this circuit is a rectangular pulse of duration  $T$ , then this input can be described as the difference of two step waves, namely

$$v_i(t) = V[u(t) - u(t - T)] \quad (1.10)$$

The response is then the superposition of two exponential pulses of (1.9) given by

$$v_o(t) = V \left[ e^{-t/RC} u(t) - e^{-(t-T)/RC} u(t - T) \right] \quad (1.11)$$

When the above is sketched, it is found that if the RC time constant of this circuit is very short in comparison with the duration of the rectangular pulse, then the output looks like two spikes. One spike at  $t = 0$  and another at  $t = T$ . Indeed, the derivative of a rectangular pulse consists of two delta functions, one at  $t = 0$  and another at  $t = T$ . This demonstrates the differentiating property of this circuit.

To test this circuit with a square wave, we would have to use one of very low frequency if we wanted to observe its full behavior at the output, from the initial value of  $V$  to the final value near 0. If the differentiating circuit is used in an amplifier interstage then it may well be that this device might have distortion and other problems at such a very low frequencies. Accordingly we prefer to perform the test with square waves of a somewhat higher frequency.

For the input  $v_i(t)$  use a square wave with a peak to peak amplitude  $V$ . Select a frequency so that the output waveform will have the appearance of the one demonstrated in figure 1.3.

Since the circuit of figure 1.2a cannot pass DC, the output waveform must be symmetrical with respect to the horizontal axis. The voltage on a capacitor cannot change instantaneously, hence any sudden jumps in the input must appear at the output. So the vertical transitions in the output waveform are of magnitude  $V$ , which correspond to the vertical transitions in the input waveform  $v_i(t)$ .

The tilt of the waveform is defined as the sag shown in figure 1.3 normalized with respect to  $V_1$ . It is given by

$$\text{tilt} = \frac{\text{sag}}{V_1} = \frac{V_1 - V_2}{V_1} \quad (1.12)$$

But  $V_2$  is the consequence of  $V_1$  which has decayed exponentially over a time duration  $T/2$ , so it is given by

$$V_2 = V_1 e^{-\frac{T}{2RC}} \quad (1.13)$$

which permits substitution of (1.13) into (1.12) to get the result

$$\text{tilt} = 1 - e^{-\frac{T}{2RC}} \quad (1.14)$$

The above can be used to accurately determine the value of the  $RC$  time constant from observations of the tilt of the output waveform. The resultant equation is

$$RC = -\frac{t}{2 \ln(1 - \text{tilt})} \quad (1.15)$$

When slide-rules were in use, the above  $\ln(\cdot)$  was approximated by its two term Taylor series expansion, replacing the above with

$$RC \approx \frac{T}{2 \cdot \text{tilt}} \quad (1.16)$$

This expression produced errors of less than 10% for values of tilt below 20%. Now that calculators are widely used, there is no particular reason to use the above approximation.

The differentiator circuit can be analyzed for the AC steady state to obtain its transfer function as a function of frequency. The result is

$$H(f) = \frac{V_o(f)}{V_i(f)} = \frac{1}{1 - jf_i/f} \quad (1.17)$$

The magnitude of  $H(f)$  is unity at frequencies at which  $f \gg f_i$ . The magnitude of the transfer function decreases as  $f$  decreases. This leads us to the conclusion that the differentiator is also a high-pass filter. At  $f = f_i$ ,  $|H(f)| = 1/\sqrt{2}$ , consequently  $f_i$  is the half power, or 3 dB, frequency of the circuit, given by

$$f_i = \frac{1}{2\pi RC} \quad (1.18)$$

We see that both the integrator and differentiator have two methods that can be used to evaluate the  $RC$  time constant. One method is square wave testing to observe the time response, the other is testing with a sequence of sine waves to determine the frequency response.

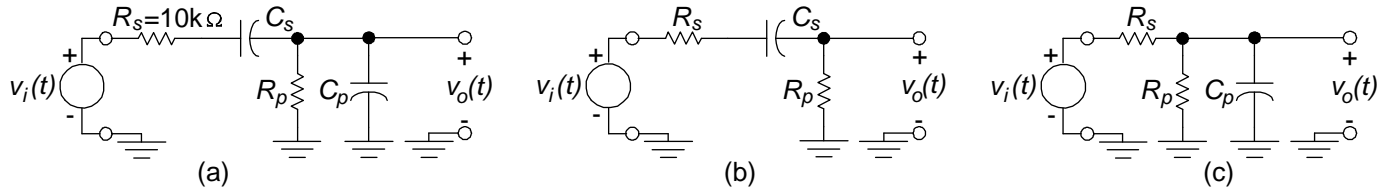

Figure 1.4: An RC coupling circuit (a). Its low frequency equivalent circuit (b) and its high frequency equivalent circuit (c).

**In your report answers the questions below.**

1. Derive (1.9) using Laplace transforms.
2. Determine how (1.16) was derived from (1.15).
3. Derive (1.17) using basic AC steady state analysis and show that (1.18) is the correct expression for  $f_l$ .
4. Derive the equivalent of (1.9 – 1.18) for the circuit shown in figure 1.2b.

## The RC Differentiating Circuit – The Experiment

Construct an RC differentiating circuit of the type shown in figure 1.2a. Apply a square wave to the input and sketch both input and output waveforms the three conditions mentioned in (1.7). Determine which one of these cases corresponds to the circuit acting as an approximate differentiator?

Using a sinusoidal signal, take data to plot the magnitude of the transfer function of your circuit. Plot  $20 \log_{10}[V_o/V_{in}]$ , which is the gain of the circuit expressed in dB, as a function of frequency using semi-log paper. Find the frequency  $f_l$  for which the gain is -3dB. Your plot should cover the frequency range  $f_l/50$  to  $10f_l$

## Determination of Circuit Elements Using Square Wave Testing

The circuit shown in figure 1.4a is enclosed in a box which has only four terminals available for applying signals and making measurements. This circuit happens to be the equivalent circuit of the coupling section for AC coupled amplifier stages. It can therefore be assumed that  $C_s$  has been selected to be much larger than  $C_p$ , the latter being the parasitic capacitance of the amplifier, that we would get rid of if we could.

It is known that  $R_s = 10\text{ k}\Omega$ . It is desired to determine the values of  $C_s$ ,  $R_p$  and  $C_p$  by performing some tests at the terminals. Since

$$C_s \gg C_p \tag{1.19}$$

it means that  $C_p$  will have a negligible effect on the performance of the coupling circuit at low frequencies. The coupling circuit of figure 1.4a can therefore be represented by the equivalent circuit of figure 1.4b for the purpose of low frequency measurements.

Because of the inequality of (1.19), we know that  $C_s$  will have a negligible effect on the performance of the coupling circuit at high frequencies. The coupling circuit of figure 1.4a can therefore be represented by the equivalent circuit of figure 1.4c when measurements are performed at high frequencies.

We see that we have in fact reduced the coupling circuit to the differentiating and integrating circuits investigated previously. To test it, it only remains for us to apply a square wave to the input, at some well chosen frequencies, and make suitable measurements on the output signal. This will produce the information needed to determine the values of  $C_s$ ,  $R_p$  and  $C_p$ .

## Propagation and Reflection of Pulses on a Cable

Some of the pieces of equipment available in this laboratory are spools of 1000 feet of RG58 cable fitted with BNC connectors at both the sending and receiving ends.

Apply a pulse train to the 1000 foot cable using a pulse generator, Choose a pulse width such that the reflected pulses do not overlap the transmitted pulses. To see the association of reflected pulses to their corresponding transmitted pulses, vary the oscillator pulse repetition frequency. Since the two-way transmission delay on the transmission line is fixed, you should be able to recognize the transmitted and reflected pulse pairs, as their time spacing remains fixed.

To determine the characteristic impedance,  $Z_0$ , of the cable, terminate the cable in a variable resistor. Observe the waveform at the sending end of the cable as the resistor is varied. When the load resistor equals  $Z_0$  the cable is matched and no reflections should take place. Compare the value of  $Z_0$  thus determined to the theoretical value for this cable.

Terminate the cable with an open circuit, a short circuit and with  $25\ \Omega$ ,  $50\ \Omega$  and  $100\ \Omega$  resistors. Sketch the waveforms observed at the input to the cable. Compare with what you would expect theoretically. From you observations determine the speed of signal propagation on RG58 cable.



## Observation of the Spectrum of Signals

1. Apply a rectangular pulse train to the spectrum analyzer and the oscilloscope. Choose a convenient frequency for easy viewing on the spectrum analyzer. Vary the pulse width so the ratio of the period to the width takes on values in the range from 3 to 6. Sketch the spectrum for two values of pulse width. Do your results agree with theory?
2. Observe the spectrum of a square wave and a triangular wave of a convenient frequency. Record the amplitude of the first few lines in each spectrum. Do the relative amplitudes of the lines agree with theory?

## The Report

There were two places in this chapter where you were asked to answer a number of questions to put in your report. In addition you will have to address the following engineering design problem, in which you will utilize the knowledge and experience you have acquired about RC circuits.

A system has available a source of a 2 kHz square wave having levels of 0 and +10 volts. The source has an output impedance of  $100\ \Omega$ . At another point in the system, a 2 kHz square wave is required having voltage levels of  $\pm 2$  volts. The input impedance at that point is  $30\text{K}\ \Omega$ . The tilt of the  $\pm 2$  volt square wave should be  $\leq 10\%$ .

Design a circuit to be connected between the two points which will satisfy the above requirements.

# Experiment 2 — Frequency Modulation and Spectra of FM Signals

## Frequency Modulation — A Tutorial

A frequency modulated (FM) wave is most readily described by the carrier signal

$$x_c(t) = A_c \cos \left[ \omega_c t + 2\pi k_f \int_{-\infty}^t x(\lambda) d\lambda \right] \quad (2.1)$$

The instantaneous angle,  $\theta(t)$ , of the above cosine wave is the value in the brackets,

$$\theta(t) = \omega_c t + 2\pi k_f \int_{-\infty}^t x(\lambda) d\lambda \quad (2.2)$$

The derivative of  $\theta(t)$  is the instantaneous radian frequency  $\omega(t)$  of the FM signal. Dividing that by  $2\pi$  produces the instantaneous frequency  $f(t)$ , given by

$$f(t) = \frac{1}{2\pi} \frac{d\theta(t)}{dt} = f_c + k_f x(t) \quad (2.3)$$

It is now clear that the instantaneous frequency of the FM signal varies around the carrier frequency  $f_c$  by an amount  $k_f x(t)$ , where  $k_f$  is the modulation constant. Positive values of  $x(t)$  produce increases in  $f(t)$ , whereas negative values of  $x(t)$  produce decreases in  $f(t)$ . If  $x(t)$  is restricted by

$$|x(t)| \leq x_{\max} \quad (2.4)$$

then the frequency of the FM wave varies around  $f_c$  by  $\pm k_f x_{\max}$ . This is the reason that  $k_f x_{\max}$  is referred to as the *maximum frequency deviation of the FM wave*

$$(\Delta f)_{\max} = k_f x_{\max} \quad (2.5)$$

It is nearly impossible to find the spectrum of an FM wave except for special waveforms of  $x(t)$ . The simplest is the sinusoidal case, given by

$$x(t) = A_m \cos \omega_m t \quad (2.6)$$

and we observe that for this sinusoid  $x_{\max} = A_m$ , hence the maximum frequency deviation in this case is

$$(\Delta f)_{\max} = k_f A_m \quad (2.7)$$

For this modulating waveform, (2.1) becomes

$$x_c(t) = A_c \cos \left( \omega_c t + \frac{k_f}{f_m} A_m \sin \omega_m t \right) \quad (2.8)$$

The notation can be simplified by defining

$$\beta = \frac{k_f}{f_m} A_m \quad (2.9)$$

so that

$$x_c(t) = A_c \cos(\omega_c t + \beta \sin \omega_m t) \quad (2.10)$$

It is obvious from the last equation that the parameter  $\beta$  is the *peak phase deviation* of the signal. It is also referred to as the *modulation index*. It is noteworthy that the modulation index is inversely related to the modulation frequency  $f_m$ .

We are now in a position to find the spectrum of the signal in (2.10). The easiest way to proceed is to write (2.10) in the exponential form

$$x_c(t) = A_c \operatorname{Re} e^{j(\omega_c t + \beta \sin \omega_m t)} \quad (2.11)$$

which can be recast into

$$x_c(t) = A_c \operatorname{Re} e^{j\omega_c t} e^{j\beta \sin \omega_m t} \quad (2.12)$$

In the above we use a well known mathematical identity in terms of  $J_n(\beta)$ , the Bessel functions of the first kind,

$$e^{j\beta \sin \omega_m t} = \sum_{n=-\infty}^{\infty} J_n(\beta) e^{jn\omega_m t} \quad (2.13)$$

to obtain

$$x_c(t) = A_c \operatorname{Re} e^{j\omega_c t} \sum_{n=-\infty}^{\infty} J_n(\beta) e^{jn\omega_m t} \quad (2.14)$$

or

$$x_c(t) = A_c \operatorname{Re} \sum_{n=-\infty}^{\infty} J_n(\beta) e^{j(\omega_c t + n\omega_m t)} \quad (2.15)$$

Table 2.1: A short table of Bessel Functions.

n	$J_n(0.1)$	$J_n(0.2)$	$J_n(0.5)$	$J_n(1.0)$	$J_n(2.0)$	$J_n(5.0)$	$J_n(10)$
0	1.00	0.99	0.94	0.77	0.22	-0.18	-0.25
1	0.05	0.10	0.24	0.44	0.58	-0.33	0.04
2			0.03	0.11	0.35	0.05	0.25
3				0.02	0.13	0.36	0.06
4					0.03	0.39	-0.22
5						0.26	-0.23
6						0.13	-0.01
7						0.05	0.22
8						0.02	0.32
9							0.29
10							0.21
11							0.12
12							0.06
13							0.03
14							0.01

The above is identical to

$$x_c(t) = A_c \sum_{n=-\infty}^{\infty} J_n(\beta) \cos(\omega_c t + n\omega_m t) \quad (2.16)$$

We finally have the result that allows us to plot the spectrum of the FM wave for a sinusoidal modulating signal. Some values of  $J_n(\beta)$  can be found in table 2.1 as well as in figure 2.1. Very thorough listings can be found in E. Jahnke, F. Emde and F. Lösch, *Tables of Higher Functions*, McGraw-Hill Book Company, 1960. A very affordable (but older) paperback version, by the first two authors, is available from Dover Books.

The procedure that was used to find the spectrum of the single tone modulated FM wave described in (2.10) can be used to find the spectrum of the multitone modulated signal

$$x_c(t) = A_c \cos(\omega_c t + \beta_1 \sin \omega_1 t + \beta_2 \sin \omega_2 t) \quad (2.17)$$

to obtain the result

$$x_c(t) = A_c \sum_{n=-\infty}^{\infty} \sum_{m=-\infty}^{\infty} J_n(\beta_1) J_m(\beta_2) \cos(\omega_c t + n\omega_1 t + m\omega_2 t) \quad (2.18)$$

The above procedure can be extended to more than two tones, but it can become rather messy. The above equation tells us that this wave contains four different kinds of frequency components.

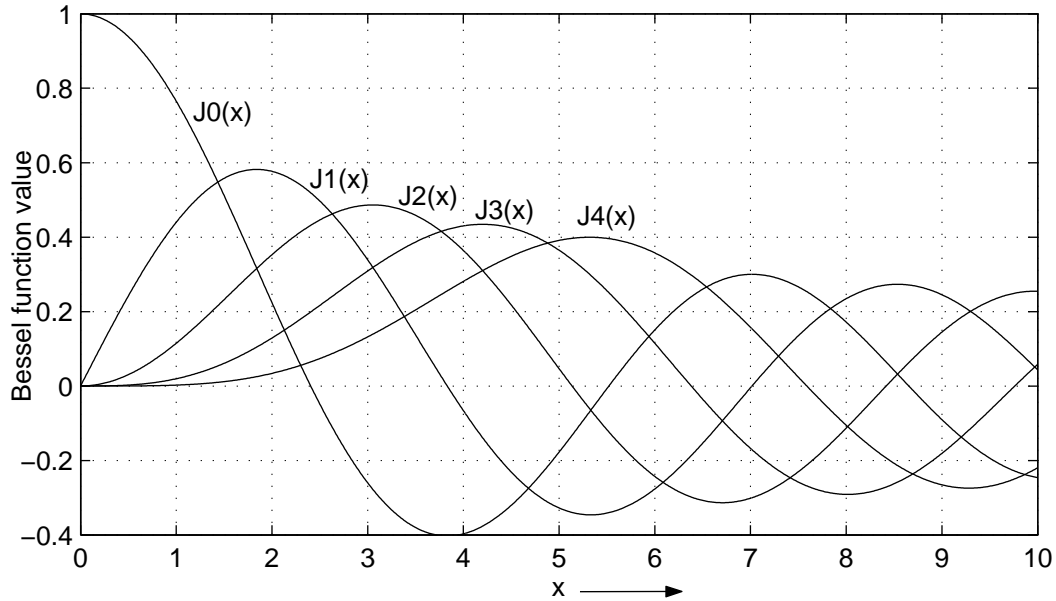

Figure 2.1: Curves of Bessel functions.

1. There is the carrier of magnitude  $A_c J_0(\beta_1) J_0(\beta_2)$ .
2. There are sidebands lines at  $f_c \pm n f_1$  due to the first tone.
3. There are sidebands lines at  $f_c \pm m f_2$  due to the second tone.
4. There are sidebands lines at  $f_c \pm n f_1 \pm m f_2$  due to both tones. This is somewhat surprising when compared to linear modulation schemes, such as AM, DSB-SC and SSB, where such lines would not appear at all. But FM is a *non-linear* modulation scheme, so this is not surprising after all.

**In your report address the item below.**

1. Derive the result in (2.18) by starting with (2.17) and using (2.13).

## Frequency Modulation — Part 1

The Wavetek generator can be used as an FM modulator by applying a modulating signal to the external input. This signal will change the frequency of the oscillator from the nominal value shown on the dial. To use this feature intelligently we have to know the change in frequency produced by a given external voltage.

Table 2.2: Values of  $\beta$  for zeros of Bessel functions.

	$J_0(\beta) = 0$	$J_1(\beta) = 0$	$J_2(\beta) = 0$
$\beta$ for 1st zero	2.40	3.83	5.14
$\beta$ for 2nd zero	5.52	7.02	8.42
$\beta$ for 3rd zero	8.65	10.17	11.62
$\beta$ for 4th zero	11.79	13.32	14.80
$\beta$ for 5th zero	14.93	16.47	17.96

Obtain data for a plot of output frequency as a function of input voltage, for DC input voltages in the range of approximately 1 volt. Set the frequency with zero input voltage to approximately 1 Mhz. Use a frequency counter for accurate determination of frequency. Use a power supply for the DC input voltage. (A  $10 \div 1$  voltage divider across the power supply will make it easier to adjust the voltage.) Draw a best fit straight line through your data. Since the slope of this straight line is the modulation constant  $k_f$  in kHz/volt, you can now determine  $k_f$  when the Wavetek is used as an FM modulator.

## Frequency Modulation — Part 2

The measurement of frequency deviation for a time varying modulating signal is not an easy thing to do in general. However, if the modulating signal is sinusoidal and we have a spectrum analyzer available, there is a nice method available for making accurate deviation measurements. This is based on the fact that at certain values of the modulation index some of the spectral components go to zero. We will use this method to measure the deviation of an FM signal produced by the Wavetek generator for a sinusoidal modulating signal and will compare our results with those of part 1. This will determine if the sensitivity of this modulator is the same for AC signals as it is for DC signals.

Apply a sinusoidal signal of some convenient frequency (10 kHz) to the modulation input (you can use the counter to measure the frequency accurately) and slowly increase the amplitude of the signal, starting with zero, until the carrier component goes to zero, or reaches a minimum. Measure the amplitude of the 10 kHz signal at this point.

Table 2.2 contains zeros of the Bessel functions. Using this table calculate the frequency deviation. Repeat this procedure using nulls of the first side band and other nulls of the carrier until you reach a deviation in the neighborhood of 100 kHz. Using this data you can plot peak deviation as a function of the peak value of the modulating signal on the same sheet as the plot of part 1. How do the two curves compare?

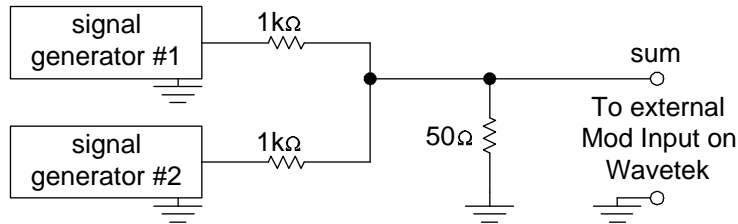

Figure 2.2: Method for summing two signals.

### Frequency Modulation — Part 3

Using the values for the sidebands given in table 2.1, adjust the amplitude of the modulating signal to produce modulation indices of 0.2, 1.0 and 5.0. Sketch the spectra for these values. Approximately how many sidebands are needed to represent the signals in each case?

### Frequency Modulation — Part 4

Using the same amplitude square waves as the sine wave amplitudes in part 3, sketch the spectrum for a square wave modulating signal. This will give you an idea of what the spectrum looks like when transmitting data using the FSK (frequency shift keying) method.

### Frequency Modulation — Part 5

In this part we will examine the spectrum of an FM signal where the modulating signal is the sum of two sinusoidal signals. This will illustrate the non-linear nature of FM. The mathematical expression for such a signal is given in (1.15) and (1.16). gives insight into the spectrum that can be expected. The sum of two signals can be obtained as shown in figure 2.2.

Choose the two audio frequencies so that the sum  $f_1 + f_2$  and the difference  $f_1 - f_2$  will not fall on harmonics of  $f_1$  or  $f_2$ . For example choosing  $f_1 = 20$  kHz and  $f_2 = 10$  kHz would not be a good choice as  $f_1 - f_2$  would fall on top of  $f_2$ .

With generator #2 disconnected adjust amplitude of generator #1 to make  $\beta_1 = 1$ . Now do the same backwards to adjust for  $\beta_2 = 1$ . Now connect both generators.

Note the appearance of spectral lines at  $f_c \pm (f_1 - f_2)$  and  $f_c \pm (f_1 + f_2)$  that were not present when either generator #1 or generator #2 was connected alone. Record the amplitudes and frequencies of terms large enough to be measurable. Identify them as the carrier, lines at  $f_c \pm n f_1$  due to the first tone, lines at  $f_c \pm m f_2$  due to the second tone and lines at  $f_c \pm n f_1 \pm m f_2$  due to both tones.

Compute the theoretical amplitude of these terms using (1.16), and compare measured and calculated values by tabulating the results neatly. Discuss how these results indicate that FM is a non-linear type of modulation.



# Experiment 3 — Amplitude Modulation and Spectra of AM Signals

## Amplitude Modulation — A Tutorial

The objective of this experiment is to become familiar with a method of generating an amplitude modulated (AM) signal and with a method of demodulating the AM signal to recover the original modulating signal.

The mathematical description of an ordinary AM signal is given by

$$x_c(t) = A_c[1 + x(t)] \cos \omega_c t \quad (3.1)$$

Where  $A_c$  is the carrier amplitude,  $x(t)$  is the modulating or message signal and  $f_c$  is the carrier frequency. To avoid overmodulation it is required that

$$|x(t)| \leq 1 \quad (3.2)$$

To facilitate both comprehension and testing, the modulating signal  $x(t)$  is taken to be a sinusoidal signal, of the form

$$x(t) = m \cos \omega_m t \quad (3.3)$$

so that (3.1) becomes

$$x_c(t) = A_c[1 + m \cos \omega_m t] \cos \omega_c t \quad (3.4)$$

The above waveform is illustrated in figure 3.1. In (3.4),  $f_m$  is the modulating frequency and  $m$  is the modulation index. Following the restriction of (3.2), the modulation index is fixed so that

$$|m| \leq 1 \quad (3.5)$$

By multiplying out (3.4) and using the trigonometric identity

$$2 \cos A \cos B = \cos(A + B) + \cos(A - B) \quad (3.6)$$

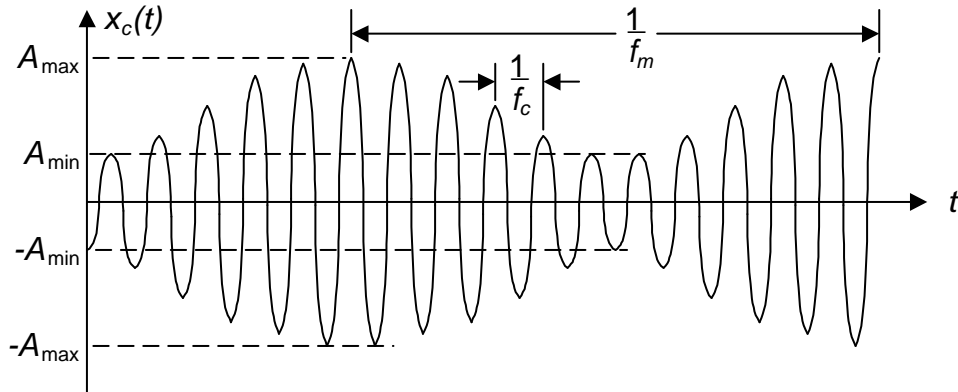

Figure 3.1: A sinusoidally modulated AM wave.

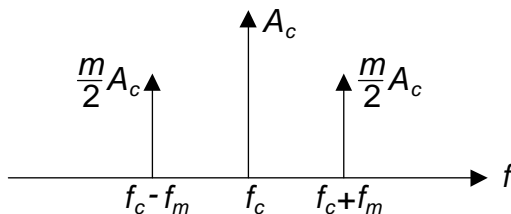

Figure 3.2: Spectrum of a sinusoidally modulated AM wave.

we obtain

$$x_c(t) = A_c[\cos \omega_c t + \frac{m}{2} \cos(\omega_c + \omega_m)t + \frac{m}{2} \cos(\omega_c - \omega_m)t] \quad (3.7)$$

This shows that the AM signal consists of the sum of three sinusoidal signals, one at the carrier frequency  $f_c$ , a sideband at  $f_c + f_m$  and another sideband at  $f_c - f_m$ . If the highest frequency contained in the signal  $x(t)$  is  $W$  Hz, then it is clear that to transmit an AM signal it is necessary to have a bandwidth of  $2W$  Hz centered at the carrier  $f_c$ .

The waveform corresponding to (3.4) is illustrated in figure 3.1. Figure 3.2 shows the spectrum corresponding to (3.7). This is the display the we should see on a spectrum analyzer when the input is the AM wave of (3.4).

The value of  $m$  can be obtained from either display. It is obvious from 3.2 how this is done using the spectrum analyzer display. To do it from the oscilloscope display, we observe that in figure 3.1 the maximum value of the AM waveform is  $A_{\max}$ , and from (3.4) we note that this equals  $A_c(1 + m)$ . In

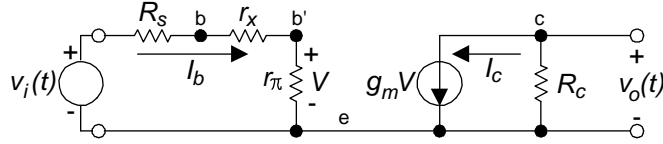

Figure 3.3: A small signal hybrid- $\pi$  model of a bipolar transistor.

other words

$$A_{\max} = A_c(1 + m) \quad (3.8)$$

Similarly for the minimum value we get

$$A_{\min} = A_c(1 - m) \quad (3.9)$$

Solving the last two equations for  $m$ , we obtain

$$m = \frac{A_{\max} - A_{\min}}{A_{\max} + A_{\min}} \quad (3.10)$$

We will now pass to the practical aspects of the subject of amplitude modulation.

## Generation of AM Signals

By examining (3.1) we see that the essence of the amplitude modulation process is the multiplication operation between  $x(t)$  and the sinusoid  $\cos \omega_c t$ . Therefore any amplitude modulator must in some way incorporate the multiplication operation. The method we will use in this experiment is illustrative of what is done in many sophisticated multipliers.

From figure 3.3 we see that the small signal collector current in a transistor operating in the active region depends on the product of  $g_m$  and  $V$ . The transconductance  $g_m$  is dependent on the operating point DC collector current. At room temperature  $g_m$  can be approximated by

$$g_m = 40I_c \quad (3.11)$$

where  $I_c$  is the DC collector current in Amperes. We also have an idea of the value of  $r_\pi$ , since

$$r_\pi = \frac{\beta}{g_m} \quad (3.12)$$

Working with the amplifier of figure 3.3, we use voltage division to find

$$V = \frac{r_\pi}{R_s + r_x + r_\pi} v_i(t) \quad (3.13)$$

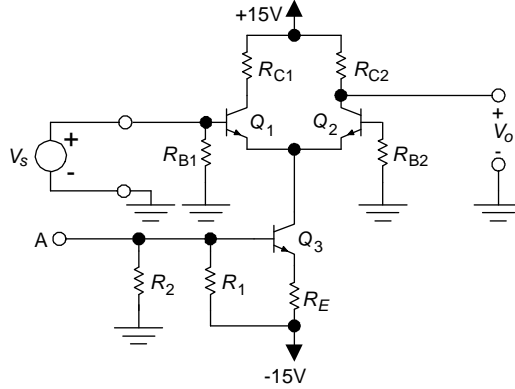

Figure 3.4: A difference amplifier.

Multiplying  $V$  by  $g_m$  gives the collector current  $I_c$ . This current passes in a negative sense through  $R_c$ . Accordingly, the gain of this stage is given by

$$A_v = \frac{v_o(t)}{v_i(t)} = -\frac{r_\pi}{R_s + r_x + r_\pi} g_m R_c \quad (3.14)$$

We are trying to create a circuit in which the gain  $A_v$  can be varied by controlling the collector current  $I_c$ . In the above expression  $g_m$  is directly proportional to  $I_c$ . Unfortunately  $r_\pi$  is inversely related to  $I_c$  which offsets somewhat the dependence of  $A_v$  on  $I_c$ . We are aided by the fact that the leading voltage divider term in the above expression can be dispensed with once we take into consideration the relative magnitudes of the terms which appear in it. An example will be helpful to make the point.

As an example we take a transistor which has a typical  $\beta = 200$ . Assume that it is biased at  $I_c = 5 \text{ mA}$ . Then from (3.11) we get  $g_m = 200 \text{ m}\Omega$ . From (3.12) it follows that this transistor has  $r_\pi = 1 \text{ k}\Omega$ . It is usual for small transistors to have  $r_x = 50 \Omega$ . If  $R_s$  is of the same order of magnitude, then the effect of  $R_s + r_x$  on the voltage  $V$  is quite small, so it causes only a small error to consider  $V \approx v_i(t)$ . This approximation allows us to rewrite (3.14) in the simpler form

$$A_v = \frac{v_o(t)}{v_i(t)} \approx -g_m R_c = -40 I_c R_c \quad (3.15)$$

In conclusion, we have established that it is possible to build amplifiers whose voltage gains are approximately proportional to  $I_c$ . It remains for us to use this principle to build an effective AM wave modulator.

A practical form of a circuit that can be used to carry out this operation is the difference amplifier shown in figure 3.4. In this circuit transistor  $Q_3$

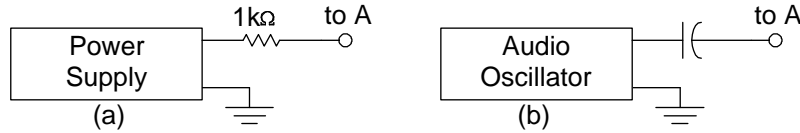

Figure 3.5: Two signal sources for connecting to point A of the difference amplifier.

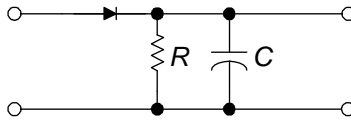

Figure 3.6: A simple envelope detector circuit.

functions as a fairly high impedance current source. Depending on how closely matched are the characteristics of transistors  $Q_1$  and  $Q_2$ , the collector current of  $Q_3$  splits almost equally between them.  $Q_3$  has almost no effect on the gain  $V_0/V_s$ , as the impedance seen looking into the collector of  $Q_3$  is very large. The gain, from the base of  $Q_1$  to the output, is given by

$$\text{gain} = \frac{V_0}{V_s} \approx \frac{g_m}{2} R_{C2} \quad (3.16)$$

Since the above gain is dependent on  $g_m$ , which in turn is dependent on  $I_c$ , then by controlling the collector current of  $Q_3$  it is possible to get multiplication of the signal at A with  $V_s$ .

## The Experiment

1. Complete the design of the circuit. Make  $R_{C1} = R_{C2} = 1 \text{ k}\Omega$ . Use small values of  $51 \Omega$  or  $100 \Omega$  for  $R_{B1}$  and  $R_{B2}$ . Design the values of  $R_E$ ,  $R_1$  and  $R_2$  for a collector current in  $Q_3$  of approximately 8 ma. Keep  $V_{CE3}$  around 8 volts and  $R_1$  and  $R_2$  in the  $3 \text{ k}\Omega$  to  $10 \text{ k}\Omega$  range.
2. Build the circuit of figure 3.4 using your design values. You can use 2N3904 for the transistors. Check and record the currents in the three transistors. This task is most easily performed by using a DVM to measure the voltages across  $R_{C1}$ ,  $R_{C2}$  and  $R_E$  and then using Ohm's law to get the currents. You can switch transistors to equalize  $I_{C1}$  and  $I_{C2}$ .

**Note: One side of the DVM must be connected to ground.**

3. When you are satisfied that the circuit is biased properly, apply a small signal  $V_s$  from the Wavetek generator at a frequency of about 100 kHz. A small signal is one that will produce an AC output about 2 volts peak to peak. Measure and record the gain  $V_0/V_s$ . Does this value agree with the result predicted by equation (3.16)? Increase the frequency of  $V_s$  until the gain decreases by 3 dB. Record this frequency. This last measurement indicates the useful frequency range of this amplifier.
4. Connect a power supply, as shown in figure 3.5a to the difference amplifier at point A. Vary the power supply voltage, in the positive and negative direction, over a range sufficient to vary the current through  $Q_3$  over the range 2 ma to 14 ma. Take data so you can plot the collector current  $I_{C3}$  and the peak to peak value of  $V_0$  as a function of power supply voltage. At all times make sure that  $V_s$  is small enough that no clipping takes place. Is the peak to peak AC output voltage a linear function of the power supply voltage?
5. Replace the power supply in the previous part with the audio oscillator circuit shown in figure 3.5b. Adjust the frequency of the audio oscillator to some convenient value between 1 kHz and 5Khz. Adjust its amplitude so that  $I_{C3}$  will vary between 4 ma and 12 ma. Observe  $V_0$  on the scope. Does it look like an AM signal? What is wrong?
6. The difficulty in the previous part can be cleared up by making  $R_{C2}$  a parallel tuned circuit. Put an coil  $L = 100 \mu\text{H}$  and a capacitor  $C$  in parallel with  $R_{C2}$ . Choose the capacitor and carrier frequency so that  $L$  and  $C$  are resonant at the frequency of the carrier. Observe and sketch the output voltage  $V_0$ . What is the maximum index of modulation for which the circuit works without appreciable distortion?
7. Design an envelope detector as shown in figure 3.6. To avoid diagonal clipping the RC product should satisfy

$$RC \leq \frac{\sqrt{1 - m^2}}{2\pi mW} \quad (3.17)$$

where  $W$  is the highest frequency contained in the AM signal. The equivalent input resistance is  $\approx R/2$ . Use this fact and (3.17) to select reasonable values of  $R$  and  $C$ . The detector input resistance should be high enough so it will not load down excessively the modulator when doing part 8.

Test your detector using the Wavetek generator as a source of an amplitude modulated signal.

Over what range of signal levels does the circuit function as a good detector? Choose a value of  $m$  in the range  $0.5 \leq m \leq 0.8$ , a modulating frequency in the range 1 to 5 kHz, and a carrier frequency of about 100 kHz.

8. Try detecting the output of your modulator with the detector you have built. Is the output of your detector a reasonable looking sinusoidal signal? Check the linearity of the system by plotting the amplitude of the AC signal output of the detector against the amplitude of the AC modulating signal into the modulator for  $0.1 \leq m \leq 0.8$ .
9. If you have time, check the performance of your system by measuring the percent distortion of the signal at the output of your detector.

# Experiment 4 — Distortion Analysis

## Distortion Analysis — A Tutorial

The object of this experiment is to become familiar with the concept of distortion and to get some practical experience in the performance of distortion measurements. Before proceeding, a short review will be undertaken.

A distortionless device is one that produces an output  $v(t)$  which is a scaled and delayed version of an input  $x(t)$ . We could summarize the relationship by

$$v(t) = kx(t - t_d) \quad (4.1)$$

where  $k$  is the scale factor and  $t_d$  is the delay of the device.

You might argue that a telephone conversation that is scaled in amplitude, provided it is audible and not earshattering, is equally as comprehensible as the unscaled version. Within reasonable bounds, a short delay in the reception of a message will not change anything. After all, we tolerate delays of more than 15 milliseconds in coast to coast conversations without taking notice.

If a device is not linear then it causes distortion. In (4.1), we will leave the delay  $t_d$  out of the discussion without losing any generality. So a distortionless device should obey the linear relation

$$v(t) = kx(t) \quad (4.2)$$

Any device in which the output is not linearly related to the input causes distortion. For example

$$v(t) = k_1x(t) + k_2x^2(t) + k_3x^3(t) + \dots \quad (4.3)$$

will cause distortion.

The easiest way of quantifying distortion is to use a sinusoidal test signal. If we use

$$x(t) = A \cos \omega_0 t \quad (4.4)$$



in (4.2) then we get an output

$$v(t) = kA \cos \omega_0 t \quad (4.5)$$

which is a scaled replica of the sinusoidal input.

If, on the other hand, we use (4.4) in (4.3) then we get the output

$$v(t) = k_1 A \cos \omega_0 t + k_2 (A \cos \omega_0 t)^2 + k_3 (A \cos \omega_0 t)^3 + \dots \quad (4.6)$$

To the above we apply some trigonometric identities to obtain

$$v(t) = A_1 \cos \omega_0 t + A_2 \cos 2\omega_0 t + A_3 \cos 3\omega_0 t + \dots \quad (4.7)$$

which indicates that at the output we have signals that we did not have at the input. The excessive signals represent distortion.

For a periodic signal, which can always be written as a Fourier expansion, the distortion is defined as the ratio of the rms value of all components other than the fundamental to the rms value of the fundamental. The distortion  $D$ , of the signal in (4.7), is

$$D = \frac{\sqrt{A_2^2 + A_3^2 + \dots}}{A_1} \quad (4.8)$$

The analyzer at our disposal does not measure the above quantity, but rather

$$DM = \frac{\sqrt{A_2^2 + A_3^2 + \dots}}{\sqrt{A_1^2 + A_2^2 + A_3^2 + \dots}} \quad (4.9)$$

It uses as a definition of distortion the ratio of the rms value of all components other than the fundamental to the rms value of the entire signal.

It is very easily verified that the measured and defined distortion are related by

$$D = \frac{DM}{\sqrt{1 - DM^2}} \quad (4.10)$$

and

$$DM = \frac{D}{\sqrt{1 + D^2}} \quad (4.11)$$

For small values of distortion,  $D$  and  $DM$  are very close to each other. For values of measured distortion greater than 0.1 it is worthwhile to use (4.10) to find the true distortion, particularly if greater accuracy is desired.

When dealing with a periodic waveshape of known form we may use a shortcut in calculating the distortion. We base this method on the idea that the mean square value of the waveform is the sum of the mean square values of all of its harmonics. Thus

$$V_{\text{rms}}^2 = \frac{A_1^2}{2} + \frac{A_2^2}{2} + \frac{A_3^2}{2} + \dots \quad (4.12)$$

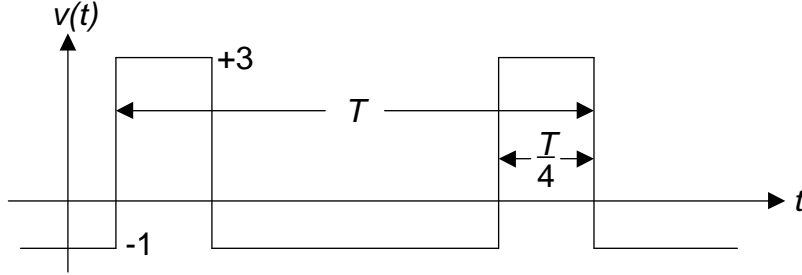

Figure 4.1: A 25% duty cycle rectangular wave.

where we used  $V_{\text{rms}}$  to represent the rms value of the signal in (4.7).

We rearrange the last equation into

$$\text{mean square value of distortion} = \frac{A_2^2}{2} + \frac{A_3^2}{3} + \dots = V_{\text{rms}}^2 - \frac{A_1^2}{2} \quad (4.13)$$

Taking the square root of both sides we obtain

$$\text{rms value of distortion} = \sqrt{\frac{A_2^2}{2} + \frac{A_3^2}{2} + \dots} = \sqrt{V_{\text{rms}}^2 - \frac{A_1^2}{2}} \quad (4.14)$$

The left hand side of the above equation is the rms value of all the distortion harmonics. This value divided by  $V_{\text{rms}}$  is the reading that the audio analyzer should display.

These ideas will be illustrated with an example. Consider the 25% duty cycle rectangular wave shown in figure 4.1. We wish find the expected reading of the analyzer in terms of  $DM$ .

For this example the rms value can be calculated by simply looking at the wave. The result is

$$V_{\text{rms}} = \sqrt{\frac{1}{4}(3)^2 + \frac{3}{4}(-1)^2} = \sqrt{3} \quad (4.15)$$

For a rectangular pulse train with pulse height  $V$ , period  $T$  and duty cycle  $\tau/T$  we find that the Fourier coefficients are given by

$$A_n = V \frac{\tau}{T} \frac{\sin(n\pi\tau/T)}{n\pi\tau/T} \quad (4.16)$$

In our example  $V = 4$  and  $\tau/T = 1/4$ . Therefore the above reduces to

$$A_n = \frac{\sin(n\pi/4)}{n\pi/4} \quad (4.17)$$

and we only need to know  $A_1$ , which is

$$A_1 = \frac{\sin(\pi/4)}{\pi/4} = 0.9003 \quad (4.18)$$

According to (4.14)

$$\text{rms value of distortion} = \sqrt{\frac{A_2^2}{2} + \frac{A_3^2}{2} + \dots} = \sqrt{3 - \frac{(0.9003)^2}{2}} = 1.61 \quad (4.19)$$

The measured value of  $DM$  should therefore be close to

$$DM = \frac{1.61}{\sqrt{3}} = 0.93 \quad (4.20)$$

Now we know what we could expect for a distortion measurement of the rectangular wave of figure 4.1.

**In your report answers the questions below.**

1. What is the relationship of the coefficients of (4.7) to those in (4.6)?
2. Derive (4.11) from (4.10) and vice versa.

## The Experiment

The required equipment is an HP 8903B audio analyzer and instruction manual, which are available in the stockroom.

1. Measure the distortion of the internal source of the analyzer. (This is just a check of the instrument.)
2. Measure the distortion of the sine wave output of the Wavetek generator at several frequencies between 100 Hz and 10 kHz.
3. Repeat for a triangle wave and a square wave at a frequency of 1 kHz. In your report, compare the measured values and what you would expect from theoretical considerations.
4. Build a one stage transistor or OP-AMP amplifier with a voltage gain of  $\approx 40$ . Increase the input signal so the output signal is barely showing signs of distortion. Measure the distortion using the distortion analyzer so that you can answer the question which follows.

What is the approximate value of the minimum distortion you are able to observe visually on the oscilloscope?

# Experiment 5 — Measurements on Noise

## Introduction

The ultimate limitations on the performance of communication systems are due to noise. Thermal noise, which is caused by the random motion of electrons in resistors cannot be eliminated and must be considered by designers of communication systems. These thermal noise voltages are typically in the order of microvolts and are not noticed when working with voltages in the order of volts. At the input of communication receivers, however, where the received signal powers may be on the order of  $10^{-12}$  watts, thermal noise power cannot be neglected. For this reason engineers working with communication systems should have some knowledge of the properties of noise.

## Noise — A Tutorial

The thermal noise produced by a resistor has an rms value that is given by

$$V_{\text{rms}} = \sqrt{4kTRB} \text{ volts} \quad (5.1)$$

The variables appearing in the above equation are defined below

$$T = \text{temperature in degrees Kelvin (}^\circ\text{K)} \quad (5.2)$$

$$k = \text{Boltzmann's constant} = 1.38 \times 10^{-23} \text{ joules/}^\circ\text{K} \quad (5.3)$$

$$R = \text{resistance in Ohms} \quad (5.4)$$

$$B = \text{bandwidth in Hz over which the noise voltage is measured} \quad (5.5)$$

As an example take a  $100 \text{ k}\Omega$  resistor at a room temperature of  $300^\circ\text{K}$ . When measured with an ideal rms voltmeter having a bandwidth of  $1 \text{ MHz}$ , it would have a noise voltage of  $20 \mu\text{V}$ .

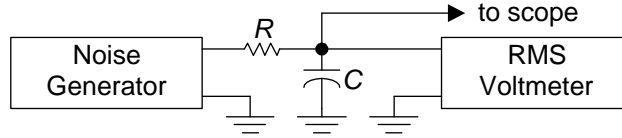

Figure 5.1: Noise measurement setup.

The two properties of an electrical noise signal we are most interested in are:

1. How its power is distributed in the frequency domain, namely we would like to know its Power Spectral Density.
2. How its amplitude is distributed in a statistical sense, namely the probability density function of its amplitude.

The thermal noise we deal with in communication systems is closely modeled as White Gaussian Noise (WGN), which means that its power spectral density is uniform over a large frequency range and the probability density function of its amplitude is Gaussian. The noise generator we will use in this experiment has an output which approximates WGN over the frequency range  $0 \leq f \leq 500$  kHz.

The relation between the power spectral density at the input and output of a linear system is given by

$$S_o(f) = S_{in}(f)|H(f)|^2 \quad (5.6)$$

Power is related to the one sided spectral density  $S(f)$  by

$$P = \int_0^{\infty} S(f)df \quad (5.7)$$

In this experiment we will not measure power, but rms voltage, which is more convenient to measure. Power is related to  $V_{\text{rms}}$  by

$$P = \frac{V_{\text{rms}}^2}{R} \quad (5.8)$$

## The Experiment

The experiment will attempt to verify that the output of the noise generator has a constant power spectral density ( $V_{\text{rms}}^2/\text{Hz}$ ) over a frequency range from DC to several hundred kilohertz. It should also familiarize the student with the appearance of Gaussian noise when viewed on an oscilloscope.

Set up the circuit shown in figure 5.1. Choose  $R$  to be some convenient value such as  $1 \text{ k}\Omega$ . Use 5 or 6 different values of  $C$  chosen such that the bandwidth of

the RC lowpass filter varies from a few hundred hertz to a few hundred kilohertz. For each value of  $C$  measure the rms voltage across the capacitor and observe it on the scope. Make rough sketches, showing height of peaks, for one value of  $C$ .

Plot the  $V_{\text{rms}}^2$  as a function of the bandwidth of the filter. Since the bandwidth will vary over a range of a few thousand, as will  $V_{\text{rms}}^2$ , so a log-log plot would be desirable. From your plot determine  $V_{\text{rms}}^2/\text{Hz}$  for the generator.

**In your report answer the following questions.** Use your communication systems book or any other communication systems book as a reference.

1. What is meant by the noise bandwidth of a filter? For the RC lowpass filter used in this experiment how are the 3 dB bandwidth and the noise bandwidth related?
2. Why is it necessary to use a “true rms meter” when measuring noise if you are to obtain accurate results?
3. How is the height of “fairly frequently seen” peaks related to the rms value of a signal. (This is meant to be a rough approximation as this term is not well defined.)