

ENGINEERED WOOD CONSTRUCTION GUIDE



WOOD

The Miracle Material



Engineered wood products are a good choice for the environment. They are manufactured for years of trouble-free, dependable use. They help reduce waste by decreasing disposal costs and product damage. Wood is a renewable, recyclable, biodegradable resource that is easily manufactured into a variety of viable products.

A few facts about wood.

■ *We're growing more wood every day.* Forests fully cover one-third of the United States' and one-half of Canada's land mass. American landowners plant more than two billion trees every year. In addition, millions of trees seed naturally. The forest products industry, which comprises about 15 percent of forestland ownership, is responsible for 41 percent of replanted forest acreage. That works out to more than one billion trees a year, or about three million trees planted every day. This high rate of replanting accounts for the fact that each year, 27 percent more timber is grown than is harvested. Canada's replanting record shows a fourfold increase in the number of trees planted between 1975 and 1990.



■ *Life Cycle Assessment shows wood is the greenest building product.* A 2004 Consortium for Research on Renewable Industrial Materials (CORRIM) study gave scientific validation to the strength of wood as a green building product. In examining building products' life cycles – from extraction of the raw material to demolition of the building at the end of its long lifespan – CORRIM found that wood was better for the environment than steel or concrete in terms of embodied energy, global warming potential, air emissions, water emissions, and solid waste production. For the complete details of the report, visit www.CORRIM.org.

■ *Manufacturing wood is energy efficient.* Wood products made up 47 percent of all industrial raw materials manufactured in the United States, yet consumed only 4 percent of the energy needed to manufacture all industrial raw materials, according to a 1987 study.

Material	Percent of Production	Percent of Energy Use
Wood	47	4
Steel	23	48
Aluminum	2	8



■ *Good news for a healthy planet.* For every ton of wood grown, a young forest produces 1.07 tons of oxygen and absorbs 1.47 tons of carbon dioxide.

Wood: It's the miracle material for the environment, for design, and for strong, lasting construction.



engineered wood products are used in a wide range of construction applications. Time-tested panel products are used in traditional wood-frame construction and in combination with other engineered wood products and systems. For low in-place cost, versatility, and superior performance, engineered wood systems are simply hard to beat.

This guide from APA is designed as a reference manual for both residential and commercial construction. It contains up-to-date information on APA Performance Rated Panels, glulam, I-joists, specification practices, floor, wall and roof systems, diaphragms and shear walls, fire-rated systems and methods of finishing.

If what you want to know about engineered wood construction systems isn't fully explained here, chances are it is in one of our many other publications. Simply write for the appropriate title or titles cited throughout this publication. Product and application information can also be found on the APA web site, at www.apawood.org. Or, for individual assistance with specific application questions or problems, contact the APA Product Support Help Desk at (253) 620-7400.

CONTENTS

GUIDE TO ENGINEERED WOOD PRODUCTS	5	WALL CONSTRUCTION	41
PANEL SELECTION AND SPECIFICATION	5	APA Sturd-I-Wall	41
Manufacturing and Performance Standards	5	APA Panel and Lap Siding Over Nailable Sheathing	43
Grade Designations	6	APA Panel Wall Sheathing	45
Sanded, Unsanded and Touch-Sanded Panels	6	APA Sheathing Under Stucco	46
Bond Classification	6	Siding Joint Details	46
Moisture Exposure Recommendations	7	APA Rated Siding Patterns and Grades	47
Group Number	7	Finishing Plywood for Exterior Exposure	49
Span Ratings	12	Interior Paneling	50
How To Order APA Panels	12	Panel Backing	51
Grade Availability	13	APA Panel Shear Walls	52
Nail Sizes	13	ROOF CONSTRUCTION	54
Metric Conversions	14	APA Panel Roof Sheathing	54
Panel Storage and Handling	14	Preframed Roof Panels	56
Panel Specification Guide	15	Long Span Systems	58
GLULAM SELECTION AND SPECIFICATION	19	Plywood Under Special Coatings	59
Balanced and Unbalanced Beams	19	APA Panel Soffits	59
Allowable Design Properties	19	APA Panel Roof Diaphragms	61
Sizes	19	BUILDING REQUIREMENTS AND	
Appearance Classification	20	RELATED PANEL SYSTEMS	63
Section Properties and Capacities	21	Fire-resistant Construction	63
Camber	21	Wind-resistive Roofs	67
Trademarks and Acceptances	22	Noise Transmission Control	68
Glulam Beam Storage and Handling	22	Energy Conservation	69
Glulam Specification Guide	23	Condensation: Its Cause and Control	70
I-JOIST SELECTION AND SPECIFICATION	24	Thermal Resistance of Wood Structural Panels	71
APA PRI-400	24	The Permanent Wood Foundation	72
Residential Floor Spans	24	Plywood for Outdoor Decks	72
I-Joist Storage and Handling	25	Plywood for Concrete Forming	72
APA Performance Rated I-Joist Specification Guide	26	Structural Insulated Panels	73
LVL SELECTION AND SPECIFICATION	27	APA Panels Over Metal Framing	73
Allowable Strength Properties	27	APA Panel Systems Over Concrete Slabs	74
Laminated Veneer Lumber (LVL) Specification Guide	27	Special Floor Surfacing	74
FLOOR CONSTRUCTION	28	ADDITIONAL INFORMATION	75
APA Rated Sturd-I-Floor	28	About APA – The Engineered Wood Association and	
Sturd-I-Floor 32 oc and 48 oc	30	Engineered Wood Systems	75
APA Performance Rated Rim Board	31		
The APA Glued Floor System	32		
APA Panel Subflooring	33		
Lightweight Concrete Over APA Panels	35		
APA Plywood Underlayment	35		
Hardwood Flooring Over APA Panel Subfloors	37		
Ceramic Tile Over APA Plywood Floors	38		
APA Panel Stair Treads and Risers	39		
Heavy Duty Plywood Floors	39		

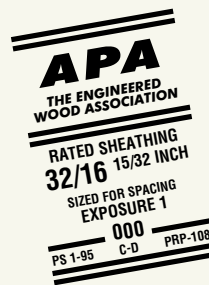
**NOTICE:**

The recommendations in this guide apply only to products that bear the APA trademark. Only products bearing the APA trademark are subject to the Association's quality auditing program.

GUIDE TO ENGINEERED WOOD PRODUCTS

Product Selection, Specification, and Handling

The evolution of engineered wood products over the past few decades has greatly expanded building options and methods in all forms of residential and commercial construction. The next 23 pages of this APA Design/Construction guide provide product information and specification recommendations for several of the most common engineered wood products – plywood, oriented strand board, glulam, and I-joists. Other engineered wood products that are often used in the construction systems described in this guide include rim board and laminated veneer lumber (LVL).

“Engineered wood” describes wood products that are engineered for structural applications. Having been used since the 1940s, plywood is considered by many to be the original engineered wood product. All glued engineered wood products are made by combining wood strands, veneers, lumber or other wood fiber with glue to form a larger composite structural unit. They are designed and manufactured to maximize the natural strength and stiffness characteristics of wood by optimally orienting the wood veneers, strands or laminations and by combining wood with durable adhesives.

PANEL SELECTION AND SPECIFICATION

Manufacturing and Performance Standards

Panels for construction and industrial applications can be manufactured in a variety of ways – as plywood (cross-laminated wood veneer), as oriented strand board (OSB), or other wood-based panel products.

Some plywood panels are manufactured under the detailed manufacturing specifications or under the performance testing provisions of Voluntary Product Standard PS 1-95 for Construction and Industrial Plywood, developed cooperatively by the plywood industry and the U.S. Department of Commerce. Other plywood panels, however, as well as composite and OSB panels, are manufactured under the provisions of APA PRP-108, Performance Standards and Qualification Policy for Structural-Use Panels, or under Voluntary Product Standard PS 2-04, Performance Standard for Wood-Based Structural-Use Panels, that establish performance criteria for specific designated construction applications.

These APA Performance Rated Panels are easy to use and specify because the recommended end use and maximum support spacings are clearly indicated in the APA trademark. By broadening the range of panel configuration and composition, APA Performance Rated Panels allow more efficient use of raw materials. APA PRP-108 Performance Standards are recognized through NER-108 by the International Code Council Evaluation Service (ICC-ES) and HUD.^(a) PRP-108, PS-1 and/or the PS-2 grade conformance where applicable are given in the lower portion of the APA trademark. Plywood panels, depending on glueline classification, veneer species and thickness, etc., are in many instances identical to panel grades as defined in Product Standard PS 1-95.

Typical APA Performance Rated Panel trademarks are illustrated and explained on page 6.

(a) ICC-ES is a nonprofit, public-benefit corporation that does technical evaluations of building products, components, methods, and materials. The evaluation process culminates with the issuance of reports on code compliance, which are made available free of charge, on the worldwide web, to building regulators, contractors, specifiers, architects, engineers, and anyone else with an interest in the building industry and construction.

ICC-ES came into being on February 1, 2003, when America’s four building-product evaluation services officially combined their operations. The four “legacy” evaluation services that came together to form ICC-ES were the National Evaluation Service, Inc.; BOCA Evaluation Services; ICBO Evaluation Service, Inc.; and SBCCI Public Service Testing and Evaluation Services, Inc.

Contact APA for the latest information about code recognition of wood structural panels.

HUD recognition of wood-based APA Performance Rated Panels is contained in Use of Materials Bulletin UM-40.

TABLE 1

VENEER GRADES

A Smooth, paintable. Not more than 18 neatly made repairs, boat, sled, or router type, and parallel to grain, permitted. Wood or synthetic repairs permitted. May be used for natural finish in less demanding applications.

B Solid surface. Shims, sled or router repairs, and tight knots to 1 inch across grain permitted. Wood or synthetic repairs permitted. Some minor splits permitted.

C Improved C veneer with splits limited to 1/8-inch width and knot-holes or other open defects limited to 1/4 x 1/2 inch. Wood or synthetic repairs permitted. Admits some broken grain.

C Tight knots to 1-1/2 inch. Knotholes to 1 inch across grain and some to 1-1/2 inch if total width of knots and knotholes is within specified limits. Synthetic or wood repairs. Discoloration and sanding defects that do not impair strength permitted. Limited splits allowed. Stitching permitted.

D Knots and knotholes to 2-1/2-inch width across grain and 1/2 inch larger within specified limits. Limited splits are permitted. Stitching permitted. Limited to Exposure 1 or Interior panels.

Grade Designations

Structural panel grades are generally identified in terms of the veneer grade used on the face and back of the panel (e.g., A-B, B-C, etc.), or by a name suggesting the panel’s intended end use (e.g., APA RATED SHEATHING, APA RATED STURD-I-FLOOR, etc.). See [Tables 2-4](#).

Veneer grades define veneer appearance in terms of natural unrepaired growth characteristics and allowable number and size of repairs that may be made during manufacture. See [Table 1](#). The highest quality commonly available veneer grade is A. The minimum grade of veneer permitted in Exterior plywood is C-grade. D-grade veneer is used in panels intended for interior use or applications protected from long-term exposure to weather.

Sanded, Unsanded and Touch-Sanded Panels

Panels with B-grade or better veneer faces are always sanded smooth in manufacture to fulfill the requirements of their intended end use – applications such as cabinets, shelving, furniture, built-ins, etc. APA RATED SHEATHING panels are unsanded since a smooth surface is not a requirement of their intended end use. Still other panels – APA UNDERLAYMENT, APA RATED STURD-I-FLOOR, APA C-D PLUGGED, and APA C-C PLUGGED – require only touch sanding for “sizing” to make the panel thickness more uniform.

Unsanded and touch-sanded panels, and panels with B-grade or better veneer on one side only, usually carry the APA trademark on the panel back. Panels with both sides of B-grade or better veneer, or with special overlaid surfaces (such as HIGH DENSITY OVERLAY) usually carry the APA trademark on the panel edge.

Bond Classification

APA trademarked panels may be produced in three bond classifications – Exterior, Exposure 1, and Interior. The bond classification relates to moisture resistance of the glue bond, and thus to structural integrity of the panel. Since aesthetic (nonstructural) attributes of panels may be compromised to some degree by exposure to weather, installation recommendations in this publication are designed to provide optimum overall performance.

Panel surfaces may become uneven and irregular under prolonged moisture exposure. Panels should be allowed to dry, and panel joints and surfaces may need to be sanded before applying some finish materials.

Bond classification of the glue bond **does not** relate to fungal decay resistance of the panel. Fungal decay of wood products may occur when the moisture content exceeds 20% for an extended period. See [APA Technical Note R495, Controlling Decay in Wood Construction](#), for a discussion of fungal decay. Prevention of fungal decay is a function of proper design, material specification, construction and maintenance of the structure. While this publication includes many of the applicable provisions, reference to local building codes and other design documents is also necessary.

The diagram illustrates three APA panel specifications with callouts 1 through 15 explaining the components of the designation. The specifications are:

- APA RATED STURD-I-FLOOR:** 1 — RATED STURD-I-FLOOR, 2 — 24 OC 23/32 INCH, 3 — SIZED FOR SPACING T&G NET WIDTH 47-1/2, 4 — EXPOSURE 1, 5 — PS 1-95 UNDERLAYMENT PRP-108, 7 — 000, 8 —
- APA RATED SHEATHING:** 1 — RATED SHEATHING, 2 — 48/24 23/32 INCH, 4 — SIZED FOR SPACING EXPOSURE 1, 5 — PS 2-84 SHEATHING PRP-108 HUD-UM-40, 7 — 000, 8 —, 11 —, 13 — CONSTRUCTION SHEATHING 2R48/2F24, 14 — 17.5mm CSA 0325, 15 — STRENGTH AXIS THIS DIRECTION
- APA RATED SIDING:** 1 — RATED SIDING 303-18-S/W, 2 — 16 OC 11/32 INCH GROUP 1, 3 — SIZED FOR SPACING EXTERIOR, 4 — 000, 5 — PS 1-95 PRP-108 HUD-UM-40, 7 —, 8 —, 9 —, 10 —, 11 —, 12 —

Legend for callouts:

- Panel grade
- Span Rating
- Tongue-and-groove
- Bond classification
- Product Standard
- Thickness
- Mill number
- APA's performance rated panel standard
- Siding face grade
- Species group number
- HUD recognition
- Panel grade, Canadian standard
- Panel mark – Rating and end-use designation per the Canadian standard
- Canadian performance rated panel standard
- Panel face orientation indicator

Exterior panels are suitable for repeated wetting and redrying or long-term exposure to weather or other conditions of similar severity.

Exposure 1 panels are suitable for uses **not** permanently exposed to weather. Panels classified as Exposure 1 are intended to resist the effects of moisture due to construction delays, or other conditions of similar severity. Exposure 1 panels may also be used when exposure to the outdoors is on the under-side only, such as at roof overhangs, although appearance characteristics of the panel grade should also be considered. Exposure 1 panels are made with the same exterior adhesives used in Exterior panels. However, because other compositional factors may affect bond performance, only Exterior panels should be used for long-term exposure to the weather.

Plywood APA Rated Sheathing Exposure 1, sometimes called “CDX” in the trade, is occasionally mistaken as an Exterior panel and erroneously used in applications for which it does not possess the required resistance to weather. “CDX” should only be used for applications as outlined under Exposure 1 above. For sheathing grade panels that will be exposed long-term to the weather, specify APA Rated Sheathing Exterior (C-C Exterior plywood under PS 1).

Interior panels which lack further glue-line information in their trademarks are manufactured with interior glue and are intended for interior applications only.

Moisture Exposure Recommendations

APA recommendations take into account bond classification as well as other panel compositional factors that may affect bond or panel performance.

The table below provides guidance regarding moisture content and recommended bond classification.

By far, most wood structural panels are used in interior or dry-use moisture conditions, where in-service moisture content will be less than 16% over the service life. In North America the typical in-service equilibrium moisture content is in the 8% to 12% range for wood structural panels. Occasionally, however, an application will subject panels to higher long-term moisture conditions, such as in locations where relative humidity is 90% or more for long periods of time.

In-Service Moisture Content	End-Use Conditions	Bond Classification	Design Moisture Conditions ^(a)
Less than 16%	Dry uses	Exposure 1 or Exterior	Dry
16% to 19%	Humid interior or protected uses	Exposure 1 or Exterior	Wet
Greater than 19%	Long-term exposure to weather	Exterior	Wet
	Other very humid or wet uses	Exterior	Wet
	Ground contact	Exterior	Wet

(a) Contact APA for specific design provisions.

Group Number

Plywood can be manufactured from over 70 species of wood. These species are divided on the basis of strength and stiffness into five Groups under Voluntary Product Standard PS 1. Strongest species are in Group 1; the next strongest in Group 2, and so on. The Group number that appears in the trademark on some APA trademarked panels – primarily sanded grades – is based on the species used for face and back veneers. Where face and back veneers are not from the same species Group, the higher Group number is used, except for sanded panels 3/8 inch thick or less and Decorative panels of any thickness. These are identified by face species because they are chosen primarily for appearance and used in applications where structural integrity is not critical. Sanded panels greater than 3/8 inch are identified by face species if C or D grade backs are at least 1/8 inch and are no more than one species group number larger. Some species are used widely in plywood manufacture; others rarely. Check local availability if a particular species is desired.

TABLE 2

**GUIDE TO APA PERFORMANCE RATED PANELS^{(a)(b)}
FOR APPLICATION RECOMMENDATIONS, SEE FOLLOWING PAGES.**

APA RATED SHEATHING
Typical Trademark

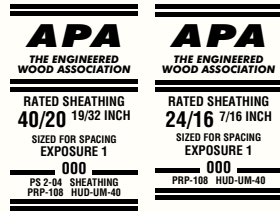

Specially designed for subflooring and wall and roof sheathing. Also good for a broad range of other construction and industrial applications. Can be manufactured as OSB, plywood, or other wood-based panel. BOND CLASSIFICATIONS: Exterior, Exposure 1. COMMON THICKNESSES: 5/16, 3/8, 7/16, 15/32, 1/2, 19/32, 5/8, 23/32, 3/4.

APA STRUCTURAL I
RATED SHEATHING^(c)
Typical Trademark

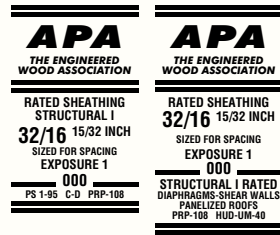

Unsanded grade for use where shear and cross-panel strength properties are of maximum importance, such as panelized roofs and diaphragms. Can be manufactured as OSB, plywood, or other wood-based panel. BOND CLASSIFICATIONS: Exterior, Exposure 1. COMMON THICKNESSES: 5/16, 3/8, 7/16, 15/32, 1/2, 19/32, 5/8, 23/32, 3/4.

APA RATED
STURD-I-FLOOR
Typical Trademark

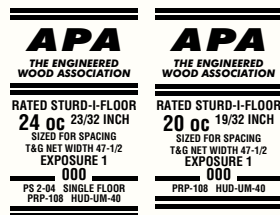

Specially designed as combination subfloor-underlayment. Provides smooth surface for application of carpet and pad and possesses high concentrated and impact load resistance. Can be manufactured as OSB, plywood, or other wood-based panel. Available square edge or tongue and-groove. BOND CLASSIFICATIONS: Exterior, Exposure 1. COMMON THICKNESSES: 19/32, 5/8, 23/32, 3/4, 1, 1-1/8.

APA RATED SIDING
Typical Trademark

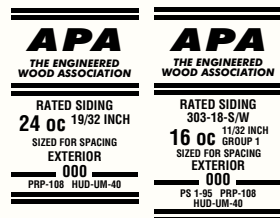

For exterior siding, fencing, etc. Can be manufactured as plywood, as other wood-based panel or as an overlaid OSB. Both panel and lap siding available. Special surface treatment such as V-groove, channel groove, deep groove (such as APA Texture 1-11), brushed, rough sawn and overlaid (MDO) with smooth- or texture-embossed face. Span Rating (stud spacing for siding qualified for APA Sturd-I-Wall applications) and face grade classification (for veneer-faced siding) indicated in trademark. BOND CLASSIFICATION: Exterior. COMMON THICKNESSES: 11/32, 3/8, 7/16, 15/32, 1/2, 19/32, 5/8.

(a) Specific grades, thicknesses and bond classifications may be in limited supply in some areas. Check with your supplier before specifying.

(b) Specify Performance Rated Panels by thickness and Span Rating. Span Ratings are based on panel strength and stiffness. Since these properties are a function of panel composition and configuration as well as thickness, the same Span Rating may appear on panels of different thickness. Conversely, panels of the same thickness may be marked with different Span Ratings.

(c) All plies in Structural I plywood panels are special improved grades and panels marked PS 1 are limited to Group 1 species. Other panels marked Structural I Rated qualify through special performance testing.

TABLE 3

GUIDE TO APA SANDED AND TOUCH-SANDED PLYWOOD PANELS^(a)(b)(c)
FOR APPLICATION RECOMMENDATIONS, SEE FOLLOWING PAGES.

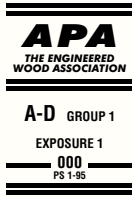
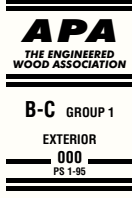
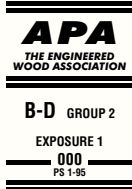
<p>APA A-A Typical Trademark (mark on panel edge)</p>	<p>A-A • G-1 • EXPOSURE 1-APA • 000 • PS1-95</p>	<p>Use where appearance of both sides is important for interior applications such as built-ins, cabinets, furniture, partitions; and exterior applications such as fences, signs, boats, shipping containers, tanks, ducts, etc. Smooth surfaces suitable for painting. BOND CLASSIFICATIONS: Interior, Exposure 1, Exterior. COMMON THICKNESSES: 1/4, 11/32, 3/8, 15/32, 1/2, 19/32, 5/8, 23/32, 3/4.</p>
<p>APA A-B Typical Trademark (mark on panel edge)</p>	<p>A-B • G-1 • EXPOSURE 1-APA • 000 • PS1-95</p>	<p>For use where appearance of one side is less important but where two solid surfaces are necessary. BOND CLASSIFICATIONS: Interior, Exposure 1, Exterior. COMMON THICKNESSES: 1/4, 11/32, 3/8, 15/32, 1/2, 19/32, 5/8, 23/32, 3/4.</p>
<p>APA A-C Typical Trademark</p>		<p>For use where appearance of only one side is important in exterior or interior applications, such as soffits, fences, farm buildings, etc.^(f) BOND CLASSIFICATION: Exterior. COMMON THICKNESSES: 1/4, 11/32, 3/8, 15/32, 1/2, 19/32, 5/8, 23/32, 3/4.</p>
<p>APA A-D Typical Trademark</p>		<p>For use where appearance of only one side is important in interior applications, such as paneling, built-ins, shelving, partitions, flow racks, etc.^(f) BOND CLASSIFICATIONS: Interior, Exposure 1. COMMON THICKNESSES: 1/4, 11/32, 3/8, 15/32, 1/2, 19/32, 5/8, 23/32, 3/4.</p>
<p>APA B-B Typical Trademark (mark on panel edge)</p>	<p>B-B • G-2 • EXT-APA • 000 • PS1-95</p>	<p>Utility panels with two solid sides. BOND CLASSIFICATIONS: Interior, Exposure 1, Exterior. COMMON THICKNESSES: 1/4, 11/32, 3/8, 15/32, 1/2, 19/32, 5/8, 23/32, 3/4.</p>
<p>APA B-C Typical Trademark</p>		<p>Utility panel for farm service and work buildings, boxcar and truck linings, containers, tanks, agricultural equipment, as a base for exterior coatings and other exterior uses or applications subject to high or continuous moisture.^(f) BOND CLASSIFICATION: Exterior. COMMON THICKNESSES: 1/4, 11/32, 3/8, 15/32, 1/2, 19/32, 5/8, 23/32, 3/4.</p>
<p>APA B-D Typical Trademark</p>		<p>Utility panel for backing, sides of built-ins, industry shelving, slip sheets, separator boards, bins and other interior or protected applications.^(f) BOND CLASSIFICATIONS: Interior, Exposure 1. COMMON THICKNESSES: 1/4, 11/32, 3/8, 15/32, 1/2, 19/32, 5/8, 23/32, 3/4.</p>

Continued on next page

TABLE 3 Continued

**GUIDE TO APA SANDED AND TOUCH-SANDED PLYWOOD PANELS^{(a)(b)(c)}
FOR APPLICATION RECOMMENDATIONS, SEE FOLLOWING PAGES.**

APA UNDERLAYMENT
Typical Trademark

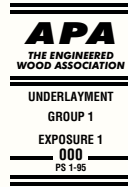

For application over structural subfloor. Provides smooth surface for application of carpet and pad and possesses high concentrated and impact load resistance. For areas to be covered with resilient flooring, specify panels with “sanded face.”^(e) BOND CLASSIFICATIONS: Interior, Exposure 1. COMMON THICKNESSES^(d): 1/4, 11/32, 3/8, 15/32, 1/2, 19/32, 5/8, 23/32, 3/4.

APA C-C PLUGGED^(g)
Typical Trademark

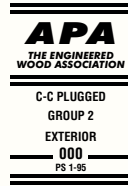

For use as an underlayment over structural subfloor, refrigerated or controlled atmosphere storage rooms, pallet fruit bins, tanks, boxcar and truck floors and linings, open soffits, and other similar applications where continuous or severe moisture may be present. Provides smooth surface for application of carpet and pad and possesses high concentrated and impact load resistance. For areas to be covered with resilient flooring, specify panels with “sanded face.”^(e) BOND CLASSIFICATION: Exterior. COMMON THICKNESSES^(d): 11/32, 3/8, 15/32, 1/2, 19/32, 5/8, 23/32, 3/4.

APA C-D PLUGGED
Typical Trademark

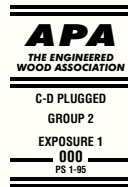

For open soffits, built-ins, cable reels, separator boards and other interior or protected applications. Not a substitute for Underlayment or APA Rated Sturd-I-Floor as it lacks their puncture resistance. BOND CLASSIFICATIONS: Interior, Exposure 1. COMMON THICKNESSES: 3/8, 15/32, 1/2, 19/32, 5/8, 23/32, 3/4.

- (a) Specific plywood grades, thicknesses and bond classifications may be in limited supply in some areas. Check with your supplier before specifying.
- (b) Sanded Exterior plywood panels, C-C Plugged, C-D Plugged and Underlayment grades can also be manufactured in Structural I (all plies limited to Group 1 species).
- (c) Some manufacturers also produce plywood panels with premium N-grade veneer on one or both faces. Available only by special order. Check with the manufacturer.
- (d) Some panels 1/2 inch and thicker are Span Rated and do not contain species group number in trademark.

- (e) Also available in Underlayment A-C or Underlayment B-C grades, marked either “touch sanded” or “sanded face.”
- (f) For nonstructural floor underlayment, or other applications requiring improved inner ply construction, specify panels marked either “plugged inner plies” (may also be designated plugged crossbands under face or plugged crossbands or core); or “meets underlayment requirements.”
- (g) Also may be designated APA Underlayment C-C Plugged.

TABLE 4

**GUIDE TO APA SPECIALTY PLYWOOD PANELS^(a)
FOR APPLICATION RECOMMENDATIONS, SEE FOLLOWING PAGES.**

APA Decorative
Typical Trademark

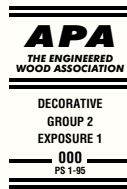

Rough-sawn, brushed, grooved, or striated faces. For paneling, interior accent walls, built-ins, counter facing, exhibit displays. Can also be made by some manufacturers in Exterior for exterior siding, gable ends, fences and other exterior applications. Use recommendations for Exterior panels vary with the particular product. Check with the manufacturer. BOND CLASSIFICATIONS: Interior, Exposure 1, Exterior. COMMON THICKNESSES: 5/16, 3/8, 1/2, 5/8.

APA High Density Overlay (HDO)^(b)
Typical Trademark (mark on panel edge)

HDO • A-A • G-1 • EXT-APA • 000 • PS 1-95

Has a hard semi-opaque resin-fiber overlay on both faces. Abrasion resistant. For concrete forms, cabinets, countertops, signs, tanks. Also available with skid-resistant screen-grid surface. BOND CLASSIFICATION: Exterior. COMMON THICKNESSES: 3/8, 1/2, 5/8, 3/4.

APA Medium Density Overlay (MDO)^(b)
Typical Trademark

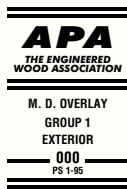

Smooth, opaque, resin-fiber overlay on one or both faces. Ideal base for paint, both indoors and outdoors. For exterior siding, paneling, shelving, exhibit displays, cabinets, signs. BOND CLASSIFICATION: Exterior. COMMON THICKNESSES: 11/32, 3/8, 15/32, 1/2, 19/32, 5/8, 23/32, 3/4.

APA Marine
Typical Trademark (mark on panel edge)

MARINE • A-A • EXT-APA • 000 • PS 1-95

Ideal for boat hulls. Made only with Douglas-fir or western larch. Subject to special limitations on core gaps and face repairs. Also available with HDO or MDO faces. BOND CLASSIFICATION: Exterior. COMMON THICKNESSES: 1/4, 3/8, 1/2, 5/8, 3/4.

APA Plyform Class I^(b)
Typical Trademark

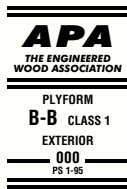

Concrete form grades with high reuse factor. Sanded both faces and mill-oiled unless otherwise specified. Special restrictions on species. Also available in HDO for very smooth concrete finish, and with special overlays. BOND CLASSIFICATION: Exterior. COMMON THICKNESSES: 19/32, 5/8, 23/32, 3/4.

APA Plyron
Typical Trademark (mark on panel edge)

PLYRON • EXPOSURE 1 • APA • 000

Hardboard face on both sides. Faces tempered, untempered, smooth or screened. For countertops, shelving, cabinet doors, flooring. BOND CLASSIFICATIONS: Interior, Exposure 1, Exterior. COMMON THICKNESSES: 1/2, 5/8, 3/4.

(a) Specific plywood grades, thicknesses and bond classifications may be in limited supply in some areas. Check with your supplier before specifying.

(b) Can also be manufactured in Structural I (all plies limited to Group 1 species).

Span Ratings

APA RATED SHEATHING, APA RATED STURD-I-FLOOR and APA RATED SIDING carry numbers in their trademarks called Span Ratings. These denote the maximum recommended center-to-center spacing in inches of supports over which the panels should be placed in construction applications. Except for APA RATED SIDING panels, the Span Rating applies when the long panel dimension or strength axis is across supports, unless the strength axis is otherwise identified. The Span Rating of APA RATED SIDING panels applies when installed vertically.

The Span Rating on APA RATED SHEATHING panels appears as two numbers separated by a slash, such as 32/16, 48/24, etc.^(a) The left-hand number denotes the maximum recommended spacing of supports when the panel is used for roof sheathing with the **long dimension or strength axis of the panel across three or more supports**. The right-hand number indicates the maximum recommended spacing of supports when the panel is used for subflooring with the **long dimension or strength axis of the panel across three or more supports**. A panel marked 32/16, for example, may be used for roof decking over supports up to 32 inches on center or for subflooring over supports up to 16 inches on center.

The Span Rating on APA RATED STURD-I-FLOOR and APA RATED SIDING panels appears as a single number. APA RATED STURD-I-FLOOR panels are designed specifically for single-floor (combined subfloor-underlayment) applications under carpet and pad and are manufactured with Span Ratings of 16, 20, 24, 32 and 48 inches. The Span Ratings for APA RATED STURD-I-FLOOR panels, like those for APA RATED SHEATHING, are based on application of the panel with the **long dimension or strength axis across three or more supports**.

APA RATED SIDING is available with Span Ratings of 16 and 24 inches. Span-rated panels and lap siding may be used direct to studs or over nonstructural wall sheathing (Sturd-I-Wall construction), or over nailable panel or lumber sheathing (double wall construction). Panels and lap siding with a Span Rating of 16 inches may be applied direct to studs spaced 16 inches on center. Panels and lap siding bearing a Span Rating of 24 inches may be used direct to studs 24 inches on center. All RATED SIDING panels may be applied horizontally direct to studs 16 or 24 inches on center provided horizontal joints are blocked. When used over nailable structural sheathing, the Span Rating of APA RATED SIDING panels refers to the maximum recommended spacing of vertical rows of nails rather than to stud spacing.

For a description of Span Ratings under the Canadian Standard for Construction Sheathing, refer to the *APA Product Guide: Oriented Strand Board*, Form W410.

How to Order APA Panels

Sanded and Touch-Sanded Panels: Designate thickness, APA trademark, grade, Group number^(b), bond classification, dimensions, number of pieces. For example:

- 3/4" APA A-A, Group 1, Exterior, 48" x 96", 100 pcs.
- 3/8" APA Underlayment, Group 1, Exposure 1, 48" x 96", 100 pcs.

(Designate "sanded face" if touch-sanded grades are to be used under resilient flooring, or see [Table 12 for additional grades](#).)

(a) Exceptions are APA RATED SHEATHING intended for use as wall sheathing only, and APA RATED WALL BRACING. The trademarks for such panels contain a single number similar to the Span Rating for APA RATED SIDING.

(b) Underlayment and C-C Plugged panels 1/2 inch and thicker are generally span rated and do not contain species group number in trademark. Designate Span Rating.

Performance Rated Panels: Designate thickness, APA trademark, grade, Span Rating, bond classification, dimensions, number of pieces. For example:

- 15/32" APA RATED SHEATHING, 32/16, Exposure 1, 48" x 96", 100 pcs.
- 23/32" APA RATED STURD-I-FLOOR 24 oc, Exterior, 48"^(c) x 96", 100 pcs. (Note “square edge” or “tongue-and-groove” as desired.)

(c) Most tongue-and-groove panels are manufactured with a 47-1/2-inch net face width, although manufacturing practices vary. Check with your supplier.

Rated Sidings: Designate thickness, APA trademark, face grade (for APA RATED SIDING-303), Span Rating, texture, pattern, dimensions, number of pieces. For example:

- 19/32" APA RATED SIDING 303-18-W, 16 oc, rough-sawn Texture 1-11[®], grooves 4" o.c., 48" x 96", 100 pcs. (Note manufacturer’s trade name if desired.)

Concrete Form: Designate thickness, APA trademark, Class, dimensions, number of pieces. For example:

- 5/8" APA PLYFORM Class I, 48" x 96", 100 pcs. (Plyform panels are manufactured only as Exterior panels and are mill-oiled unless otherwise specified.)

Overlaid Panels: Designate thickness, APA trademark, grade, Group number, dimensions, number of pieces. For example:

- 1/2" APA MEDIUM DENSITY OVERLAY (MDO) or (APA RATED SIDING 303-OL in the case of overlaid panels produced under the APA RATED SIDING-303 manufacturing specification), Group 1, 48" x 96", 100 pcs. (Any special requirements, such as only one side overlaid, surface texture or weight of surfacing material, should be stated after the standard specification.)

Grade Availability

Some panel grades, thicknesses, Span Ratings, or species may be difficult to obtain in some areas. Check with your supplier for availability or include an alternate panel in specifications. Standard panel dimensions are four feet by eight feet, although some mills also produce panels nine or ten feet or longer.

Nail Sizes

Various nail penny sizes are referenced throughout this document. For most cases, the appropriate lengths and wire sizes can be found in Table 5.

TABLE 5

NAIL SIZES (ASTM F 1667)

Penny Size (d)	Type	Length (in.)	Wire Diameter (in.)
3d	Ring- or screw-shank	1-1/4	0.099*
	Finish	1-1/2	0.072
4d	Box and casing	1-1/2	0.080
	Ring- or screw-shank	1-1/2	0.099*
6d	Finish	2	0.092
	Box and casing	2	0.099
	Siding	1-7/8	0.106
	Common	2	0.113
	Ring- or screw-shank	2	0.120
8d	Finish	2-1/2	0.099
	Box and casing	2-1/2	0.113
	Siding	2-3/8	0.128
	Common	2-1/2	0.131
	Ring- or screw-shank	2-1/2	0.131*
10d	Box and casing	3	0.128
	Common	3	0.148
	Ring- or screw-shank	3	0.148

*ISANTA NER-272

Metric Conversions

Metric equivalents of nominal thicknesses and common sizes of wood structural panels are tabulated below (1 inch = 25.4 millimeters):

PANEL NOMINAL DIMENSIONS (Width x Length)		
ft	mm	m (approx.)
4 x 8	1219 x 2438	1.22 x 2.44
4 x 9	1219 x 2743	1.22 x 2.74
4 x 10	1219 x 3048	1.22 x 3.05

PANEL NOMINAL THICKNESS	
in.	mm
1/4	6.4
5/16	7.9
11/32	8.7
3/8	9.5
7/16	11.1
15/32	11.9
1/2	12.7
19/32	15.1
5/8	15.9
23/32	18.3
3/4	19.1
7/8	22.2
1	25.4
1-3/32	27.8
1-1/8	28.6

Panel Storage and Handling

Like all building materials, APA trademarked structural wood panels should be properly stored, handled and installed to assure superior in-service performance.

Protect the edges and ends of panels, especially tongue-and-groove and shiplap-edged panels. Place panels to be moved by forklift on pallets or bunks when received to avoid damage by fork tines.

Panels to be transported on open truck beds should be covered with standard tarpaulins. For open railcar shipment, use “lumber wrap” to avoid extended weather exposure.

Store panels whenever possible under a roof, especially if they won’t be used soon after received. Keep sanded and other appearance grades away from open doorways, and weight down the top panel in a stack to help avoid any possible warpage from humidity. If moisture absorption is expected, cut steel banding on panel bundles to prevent edge damage.

Panels to be stored outside should be stacked on a level platform supported by 4x4 stringers or other blocking. Never leave panels or the platform in direct contact with the ground. Use at least three full-width supports along the eight-foot length of the panel – one centered and the others 12 to 16 inches from each end.

Cover the stack loosely with plastic sheets or tarps. Anchor the covering at the top of the stack, but keep it open and away from the sides and bottom to assure good ventilation. Tight coverings prevent air circulation and, when exposed to sunlight, create a “greenhouse” effect which may encourage mold formation.

PANEL STORAGE

Build platform of cull panel and scrap lumber 4x4s for stacking panels.

Stretch plastic film over platform to block passage of ground moisture.

Nail film to top panel and drape over ends for protection against driving rain. Weight lower end with 2x4.

Lay two 2x4s on top of stack. Pad corners with rags.

Stretch film over stack and secure to tie-down stakes.

PANEL SPECIFICATION GUIDE⁽¹⁾

CSI* Division 3 – Concrete Formwork

A. Materials

1. Forms – Plywood concrete forms shall be (specify appropriate grade):⁽²⁾

APA PLYFORM CLASS I EXT, or
 APA HIGH DENSITY OVERLAY
 PLYFORM CLASS I EXT.

Use plywood thickness sufficient to support concrete at temperature and rate poured⁽³⁾; securely brace and shore forms to prevent displacement and to safely support construction loads.

CSI* Division 6 – Wood and Plastics

A. General Provisions

1. Identification Requirements – Each panel shall be identified with the appropriate trademark of APA, and shall meet the requirements of the latest edition of Voluntary Product Standard PS 1, Voluntary Product Standard PS 2 or APA PRP-108 Performance Standards.

2. All panels which have any edge or surface exposed long term to the weather shall be classed Exterior.⁽⁴⁾⁽⁵⁾

3. Panel thickness, grade, and Group number or Span Rating shall be at least equal to that shown on the drawings.⁽⁶⁾ Application shall be in accordance with recommendations of APA.⁽⁷⁾

B. Roof Sheathing

1. Panel roof sheathing shall be (specify appropriate grade):

APA RATED SHEATHING EXP 1
 APA RATED SHEATHING EXT
 APA RATED SHEATHING/CEILING
 DECK EXP 1
 APA STRUCTURAL I RATED
 SHEATHING EXP 1, or
 APA STRUCTURAL I RATED
 SHEATHING EXT.

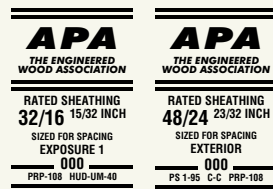

Sheathing exposed long term to weather shall be classed Exterior.⁽⁵⁾

Install with the long dimension or strength axis of the panel across supports, except where noted⁽⁸⁾, and with panel continuous over two or more spans. For pitched roofs, place screened surface or side with skid-resistant coating up, if OSB panels are used. Wear skid-resistant shoes when installing roof sheathing and keep roof deck free of dirt, debris and sawdust during construction. Suitable edge support shall be provided where indicated on drawings (or in recommendations of APA)⁽⁶⁾ by use of panel clips, tongue-and-groove edges, or lumber blocking between joists. Panel end joints shall occur over framing.

Spacing of 1/8" is recommended at all panel ends and edges, unless otherwise indicated by the panel manufacturer.⁽⁹⁾

Nail 6" o.c. along supported panel edges and 12" o.c. at intermediate supports, except that when supports are spaced 48" o.c. or more, space nails 6" o.c. at all supports. Use 8d common nails, except that when panels are 1-1/8", use 8d ring-shank or 10d common.⁽¹⁰⁾⁽¹¹⁾⁽¹²⁾⁽²⁴⁾

Cover roof sheathing as soon as possible with roofing felt or shingle underlayment for protection against excessive moisture prior to roofing application.

C. Floors

1. Subflooring (under structural finish floor such as wood strip or underlayment) – Panel subflooring shall be (specify appropriate grade):

APA RATED SHEATHING EXP 1
 APA RATED SHEATHING EXT
 APA STRUCTURAL I RATED
 SHEATHING EXP 1, or
 APA STRUCTURAL I RATED
 SHEATHING EXT.

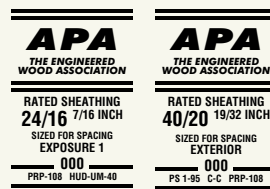

Install with the long dimension or strength axis of the panel across supports and with panel continuous over two or more spans. Panel end joints shall occur over framing. **Spacing of 1/8" is recommended at panel ends and edges**, unless otherwise indicated by the panel manufacturer.⁽⁹⁾

Nail 6" o.c. along supported panel edges and 12" o.c. at intermediate supports with 6d common nails for panels 1/2" or less, 8d for greater thicknesses.⁽²⁴⁾ Where panels are 1-1/8" thick and supports are 48" o.c., nails shall be 8d ring-shank or 10d common and spaced 6" o.c. at all supports.⁽¹⁰⁾⁽¹¹⁾⁽¹²⁾⁽²⁴⁾

Sand subfloor joints if necessary to smooth surface prior to installing underlayment or finish flooring.

2. Combined subfloor-underlayment (under carpet and pad)⁽¹³⁾ – Combined subfloor-underlayment panels shall be (specify appropriate grade):

APA RATED STURD-I-FLOOR EXP 1, or
 APA RATED STURD-I-FLOOR EXT.

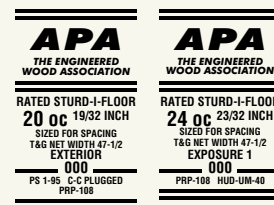

Install with the long dimension or strength axis of the panel across supports and with panel continuous over two or more spans. Panel edges shall be tongue-and-groove or supported on 2-inch lumber blocking installed between joists. Protect against damage until finish floor is installed.

Stagger panel end joints. Panel end joints shall occur over framing. **Spacing of 1/8" is recommended at panel ends and edges**, unless otherwise indicated by the panel manufacturer.⁽⁹⁾

*Construction Specifications Institute
 Notes to Specifiers on page 18

For nailed floors, nail panels 6" o.c. at supported panel edges and 12" o.c. at intermediate supports, except that when supports are spaced 48" o.c., space nails 6" o.c. at all supports. Use 6d ring- or screw-shank nails for panels 3/4" thick or less, and 8d for thicker panels.⁽²⁴⁾ With 1-1/8" panels, 10d common nails may be used if supports are well seasoned.⁽¹⁰⁾⁽¹¹⁾⁽¹²⁾⁽²⁴⁾

Fill and thoroughly sand edge joints.⁽¹⁴⁾ Lightly sand any surface roughness, particularly around fasteners.

For field-glued floors, use adhesives meeting **APA Specification AFG-01** or **ASTM D3498**, applied in accordance with the manufacturer's recommendations. If OSB panels with sealed surfaces and edges are used, use only solvent-based glues; check with panel manufacturer. Apply continuous line of glue (1/4" thick) on joists, and continuous or spaced line of glue (1/8" thick) in groove of tongue-and-groove panels. Use 6d ring- or screw-shank nails spaced 12" o.c. at panel ends and intermediate bearings.⁽¹⁰⁾⁽¹⁵⁾⁽²⁴⁾

3. Underlayment (over subflooring) – Plywood underlayment shall be (specify appropriate grade)⁽¹⁶⁾:

- APA UNDERLAYMENT INT
- APA UNDERLAYMENT EXP 1
- APA UNDERLAYMENT C-C PLUGGED EXT, or
- APA C-C PLUGGED EXT.

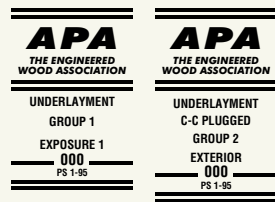

When 19/32" or thicker, APA RATED STURD-I-FLOOR EXP 1 or 2 or APA RATED STURD-I-FLOOR EXT may be specified. Apply underlayment just prior to laying finish floor and protect against damage until finish floor is installed.

For maximum stiffness, install underlayment with the face grain across supports. Stagger panel end joints (optional under carpet and pad) with respect to each other and offset all joints by at least

two inches from joints in the subfloor panels. **Butt panel ends and edges to a close but not tight fit (1/32" space is recommended).** Nail 6" o.c. along panel edges and 8" o.c. each way throughout remainder of panel with 3d ring-shank nails for panel thicknesses of 11/32" to 1/2", or 4d spaced 6" o.c. along edges and 12" o.c. each way for thicker panels up to 3/4".⁽¹¹⁾⁽¹⁷⁾⁽²⁴⁾ Fastener length should be approximately equal to the total thickness of the underlayment and sub-floor.

Fill and thoroughly sand edge joints.⁽¹⁴⁾ Lightly sand any surface roughness, particularly around fasteners.

D. Wall Sheathing

1. Panel wall sheathing shall be (specify appropriate grade):

- APA RATED SHEATHING EXP 1
- APA RATED SHEATHING EXT
- APA STRUCTURAL I RATED SHEATHING EXP 1,
- APA STRUCTURAL I RATED SHEATHING EXT, OR
- APA RATED WALL BRACING EXP 1.

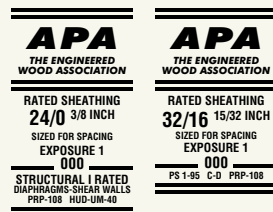

Spacing of 1/8" is recommended at panel ends and edges, unless otherwise indicated by the panel manufacturer.⁽⁹⁾

Nail 6" o.c. along supported panel edges and 12" o.c. at intermediate supports with 6d common nails for panels 1/2" and less, and 8d for greater thicknesses.⁽¹⁰⁾⁽¹²⁾⁽²⁴⁾

Apply building paper over panel wall sheathing.

E. Treated Plywood

1. Fire-retardant-treated plywood – All plywood shall be pressure-treated in accordance with American Wood-Preservers' Association Standard AWPA C27 with an approved (low hygroscopic, high temperature Interior Type A-HT) (Exterior Type) fire retardant. Each panel shall be labeled or marked by an approved independent testing agency.

After treatment, plywood shall be dried to an average moisture content of 15 percent or less.

Plywood shall be all-veneer APA RATED SHEATHING (or better, depending on appearance desired) EXP 1 or EXT.

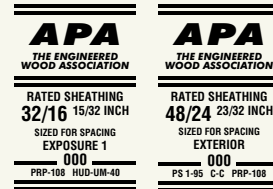

Note: Span Ratings and load capacities are based on untreated panels, and may not apply following fire-retardant treatment (FRT). Obtain structural performance characteristics of FRT panels from the company providing the treatment and redrying service.

2. Preservative-treated plywood –

Treated plywood for (state application) shall be pressure-treated in accordance with AWPA C9 with (creosote) (penta-chlorophenol) (waterborne) preservatives, as required for (coastal water) (wood foundation) (ground contact) (above ground) exposure. Plywood treated with waterborne preservatives shall be dried after treatment to a moisture content of 18 percent or less.

All treated plywood used in the Permanent Wood Foundation System (PWF) shall be marked by an approved inspection agency certified to inspect preservative-treated wood, indicating compliance with the treating, drying, retention and penetration requirements of AWPA Standard C22, or equivalent code-approved preservative-treating and quality control requirements.

Plywood shall be all-veneer APA RATED SHEATHING (or better, depending on appearance desired) EXP 1 or EXT.

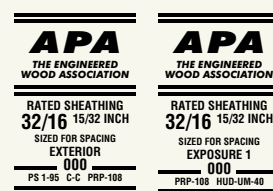

[Notes to Specifiers on page 18](#)

F. Glued Plywood Components

1. General – All plywood components shall be fabricated in accordance with the appropriate APA Fabrication Specification.⁽¹⁸⁾ Each original plywood panel shall bear the appropriate trademark of APA. Glue shall be of resorcinol or phenolic resin base (for outdoor exposure), or casein with a mold inhibitor (for indoor exposure).

CSI* Division 7 – Thermal and Moisture Protection

A. Siding

Siding shall be (specify appropriate grade):⁽¹⁹⁾

APA RATED SIDING EXT, or

APA MEDIUM DENSITY OVERLAY (MDO) EXT.

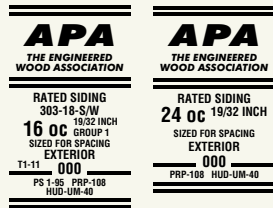

Spacing of 1/8" is recommended at panel ends and edges, unless otherwise indicated by the panel manufacturer. Nail panel siding 6" o.c. along panel edges and 12" o.c. at intermediate supports with 6d nonstaining⁽²⁰⁾ box, casing or siding nails for panels 1/2" and less, and 8d for greater thicknesses.⁽¹⁰⁾⁽²⁴⁾

Nail lap siding installed over nailable panel or lumber sheathing 8" o.c. along bottom edge, unless otherwise recommended by manufacturer. Nail lap siding installed direct to studs or over nonstructural sheathing at each stud. Use 6d nonstaining⁽²⁰⁾ box, casing, or siding nails for siding 1/2" thick, and 8d for thicker panels.⁽²⁴⁾ If siding is applied over nonstructural sheathing, use next regular nail size. Use nonstaining box nails for siding installed over foam insulation sheathing.

Prior to installing siding, apply building paper over studs or sheathing.⁽⁶⁾

All panel edges should be sealed. For panels to be painted, sealer can be paint primer; for panels to be stained, sealer should be a water-repellent preservative compatible with the finish.

B. Soffits

Soffits shall be (specify appropriate grade):⁽⁵⁾

APA A-C EXT

APA B-C EXT

APA C-C P&TS EXT

APA RATED SIDING 303 EXT,⁽¹⁹⁾ or

APA MEDIUM DENSITY OVERLAY (MDO) EXT.⁽²¹⁾

Nail 6" o.c. at supported panel edges and 12" o.c. at intermediate supports, with 6d nonstaining⁽²⁰⁾ box, casing, or siding nails for panels 1/2" and less, and 8d for thicker panels up to 3/4".⁽²⁴⁾

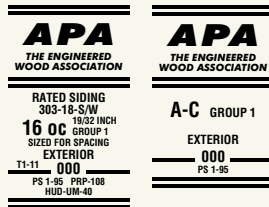

CSI* Division 9 – Finishes (Painting)⁽¹⁹⁾

A. Preparation of Surfaces

1. Exterior Panels – Panels to be exposed outdoors shall have all edges sealed. With paint, sealer may be a liberal coat of exterior house paint primer. With stain, seal with water-repellent preservative compatible with finish coat.

Surface shall be clean, dry and free of loose wood fibers.

2. Interior Panels – Surface shall be clean, dry and free of loose wood fibers. Holes and cracks shall be filled with putty or plastic wood (except for rustic type panels intended for stain finish). After dry, sand lightly in the direction of the grain of face veneer or texture to match existing surfaces.

Any tree pitch or sap spots shall be first touched up with a sealer.

B. Application of Finish

(Specify by brush, roller, or spray; brush application of the first coat gives best performance.)

Exterior Panels, Painted – *First coat:*

Exterior stain-blocking primer as recommended by manufacturer of finish coat. (May be tinted.) Apply quantity as recommended by paint manufacturer.

Second coat: Top-quality exterior all-acrylic latex house paint designed for use with primer; color as selected. Two topcoats provide better performance.

Exterior Panels, Stained – *First coat:*

Top-quality exterior penetrating semitransparent oil stain where grain showthrough is desired⁽²²⁾; or heavily pigmented solid-color oil or latex stain where grain is to be masked⁽²³⁾; color as selected. Apply in one or two coats as recommended by manufacturer.

Use stain-blocking primer with light-colored solid-color latex stains.

Interior Panels, Painted – *First coat:*

Stain-blocking primer as recommended by manufacturer of finish coat.

Second coat: Flat, semi-gloss or gloss topcoat designed for use with primer; color as selected. Use two topcoats if needed to cover.

Interior Panels, Color Tone – *First coat:*

Stain and companion sealer mixed to selected color (or sealer, then stain applied separately).

Second coat: Interior satin varnish (additional coats can be applied as desired for depth of luster).

Interior Panels, Light Stain – *First coat:*

Pigmented resin sealer (wiped off when tacky).

Second coat: Clear resin sealer.

Third coat: Tinted undercoat; thin enamel; pigmented sealer; or light stain applied thinly and wiped to the desired color depth; color as selected.

Fourth coat: Interior satin varnish (additional coats can be applied as desired for depth of luster).

*Construction Specifications Institute Notes to Specifiers on page 18

Notes to Specifiers:

- (1) The APA trademarks shown here are typical examples only. Refer to the following sections for specific panel grade and thickness recommendations.
- (2) Structural I grade (all plies limited to Group 1 species) can be specified when greater stiffness or strength is required.
- (3) Thickness recommendations are contained in [APA Design/Construction Guide: Concrete Forming, Form V345](#).
- (4) Exposure 1 may be specified for applications where temporary exposure to the weather will be required.
- (5) Open soffits or roof sheathing exposed on the underside may be any panel classed Exposure 1 where appearance is not a major consideration.
- (6) Refer to the appropriate application recommendations in this brochure.
- (7) References to APA's recommendations may allow subsequent specification concerning nailing, edge support and panel orientation to be omitted.
- (8) Long dimension of panel may be parallel to supports if panel has adequate thickness. See [Table 28](#) for roof panels applied parallel to supports.
- (9) Supported panel joints shall occur approximately along the centerline of framing with a minimum bearing of 1/2".
- (10) Engineered shear walls and diaphragms may require additional nailing. See recommendations in [Tables 24](#) and [33](#). Diagonal bracing is not required for braced wall sections when panel wall sheathing, APA RATED WALL BRACING or panel siding (APA RATED SIDING) is used.
- (11) Other code-approved fasteners may be used.
- (12) Fasteners shall be located 3/8" from panel edges.
- (13) Specify veneer-faced STURD-I-FLOOR with "sanded face" when resilient flooring is to be applied (or see Footnote 16 for additional grades). Otherwise, an additional layer of "sanded face" underlayment is recommended when resilient flooring is to be applied over STURD-I-FLOOR.
- (14) This step may not be necessary under some carpet and structural flooring products – check with flooring manufacturer.
- (15) Major model building codes accept 12" spacing with glue but some local codes may require closer spacing at edges. When panels greater than 3/4" thick are used in glued floors, use same fastener schedule as for nailed-only construction.
- (16) For areas to be covered with resilient flooring or fully adhered carpeting, specify Underlayment or C-C Plugged panel grades marked "sanded face." Underlayment A-C, Underlayment B-C, Marine EXT or sanded plywood grades marked "Plugged Crossbands Under Face," "Plugged Crossbands (or Core)," "Plugged Inner Plies" or "Meets Underlayment Requirements" may also be used under resilient flooring or fully adhered carpeting.
- (17) For 1/4"-thick panels, nail 3" o.c. along panel edges and 6" o.c. each way throughout remainder of panel, with 3d ring-shank nails.
- (18) Design and fabrication specifications for plywood box beams, stressed-skin panels, curved panels, sandwich panels and all-plywood beams are available from APA.
- (19) See [APA Product Guide: Performance Rated Siding, E300](#).
- (20) Hot-dip or hot-tumbled galvanized steel nails are recommended for most siding applications. For best performance, stainless steel nails or aluminum nails should be considered. APA tests also show that electrically or mechanically galvanized steel nails appear satisfactory when plating meets or exceeds thickness requirements of ASTM A641 Class 2 coatings, and is further protected by yellow chromate coating.
Note: Galvanized fasteners may react under wet conditions with the natural extractives of some wood species and may cause staining if left unfinished. Such staining can be minimized if the siding is finished in accordance with APA recommendations, or if the roof overhang protects the siding from direct exposure to moisture and weathering.
- (21) Specify MDO plywood with one face of Medium Density Overlay as described in Voluntary Product Standard PS 1.
- (22) Semitransparent stains may be used on plywood face grades 303-OC, 303-NR and 303-6-W. Other 303 face grades should not be finished with semitransparent stains unless specifically recommended by the panel manufacturer.
- (23) Only latex formulations are recommended on APA 303-SR and 303-NR grades of plywood siding.
- (24) See [Table 5](#) for nail dimensions.

GLULAM SELECTION AND SPECIFICATION

A glulam is made up of wood laminations, or “lams” that are bonded together with adhesives. The grain of all laminations runs parallel with the length of the member. Individual lams typically are 1-3/8 inches thick for southern pine and 1-1/2 inches thick for Western species, although other thicknesses may also be used. Glulam products typically range in net widths from 2-1/2 to 10-3/4 inches although virtually any width can be custom produced.

Balanced and Unbalanced Beams

Glulam may be manufactured as unbalanced or balanced members.

The most critical zone of a glulam bending member with respect to controlling strength is the outermost tension zone. In unbalanced beams, the quality of lumber used on the tension side of the beam is higher than the lumber used on the corresponding compression side, allowing a more efficient use of the timber resource. Therefore, unbalanced beams have different bending stresses assigned to the compression and tension zones and must be installed accordingly. To assure proper installation of unbalanced beams, the top of the beam is clearly stamped with the word “TOP.” Unbalanced beams are primarily intended for simple-span applications even though they can also be used in multiple-span applications when properly designed.

Balanced members are symmetrical in lumber quality about the mid-height. Balanced beams are used in applications such as long cantilevers or continuous spans, where either the top or bottom of the member may be highly stressed in tension due to service loads. They can also be used in single span applications, although an unbalanced beam is more efficient for this use.

STANDARD BEAM LAYUP

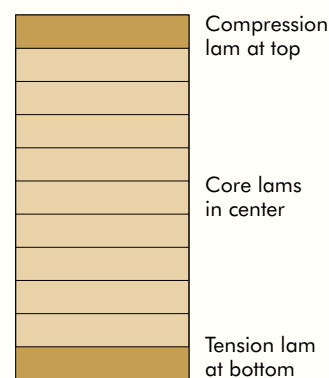

Allowable Design Properties

Allowable design properties are a key factor in specifying glulam. Bending members are typically specified on the basis of the maximum allowable bending stress of the member. For example, a 24F designation indicates a member with an allowable bending stress of 2400 psi. Similarly, a 20F designation refers to a member with an allowable bending stress of 2000 psi. These different stress levels are achieved by varying the species and percentages and grade of higher quality lumber in the beam layup.

To identify whether the lumber used in the beam is visually or mechanically graded, the stress combination also includes a second set of designations. For example, for an unbalanced 24F layup using visually graded lumber, the layup designation may be identified as a 24F-V4. The “V” indicates that the layup uses visually graded lumber. (“E” is used for mechanically graded lumber.) The number “4” further indicates a specific combination of lumber used to which a full set of design stresses such as horizontal shear, MOE, etc., are assigned. The glulam industry recently introduced the concept of specifying glulam based on a stress class system similar to that used for MSR lumber or LVL. This requires only specifying an Fb - E value. Typical stress classifications are in [Table 6](#). See also [Engineered Wood Systems Data File: Glulam Design Properties and Layup Combinations, Form EWS Y117](#).

Sizes

Glulam is available in both custom and stock sizes. Stock beams are manufactured in commonly used dimensions and cut to length when the beam is ordered from a distributor or dealer. Typical stock beam widths used in residential construction include: 3-1/8", 3-1/2", 5-1/8", 5-1/2", and 6-3/4".

TABLE 6

DESIGN VALUES FOR STRUCTURAL GLUED LAMINATED SOFTWOOD TIMBER**(Members stressed primarily in bending)** (Tabulated design values are for normal load duration and dry service conditions.)

Stress Class	Bending About X-X Axis Loaded Perpendicular to Wide Faces of Laminations					Bending About Y-Y Axis Loaded Parallel to Wide Faces of Laminations				Axially Loaded			Fasteners
	Extreme Fiber in Bending		Compression Perpendicular to Grain	Shear Parallel to Grain (Horizontal)	Modulus of Elasticity	Extreme Fiber in Bending	Compression Perpendicular to Grain	Shear Parallel to Grain (Horizontal)	Modulus of Elasticity	Tension Parallel to Grain	Compression Parallel to Grain	Modulus of Elasticity	Specific Gravity for Fastener Design
	Tension Zone Stressed in Tension (Positive Bending)	Compression Zone Stressed in Tension (Negative Bending)											
F_{bx}^+ (psi)	$F_{bx}^{-(1)}$ (psi)	$F_{c\perp x}$ (psi)	$F_{vx}^{(4)}$ (psi)	E_x (10 ⁶ psi)	F_{by} (psi)	$F_{c\perp y}$ (psi)	$F_{vy}^{(5)}$ (psi)	E_y (10 ⁶ psi)	F_t (psi)	F_c (psi)	E_{axial} (10 ⁶ psi)	G	
16F-1.3E	1600	925	315	195	1.3	800	315	170	1.1	675	925	1.2	0.42
20F-1.5E	2000	1100	425	210 ⁽⁶⁾	1.5	800	315	185	1.2	725	925	1.3	0.42
24F-1.7E	2400	1450	500	210 ⁽⁶⁾	1.7	1050	315	185	1.3	775	1000	1.4	0.42
24F-1.8E	2400	1450 ⁽²⁾	650	265 ⁽³⁾	1.8	1450	560	230 ⁽³⁾	1.6	1100	1600	1.7	0.50 ⁽¹⁰⁾
26F-1.9E ⁽⁷⁾	2600	1950	650	265 ⁽³⁾	1.9	1600	560	230 ⁽³⁾	1.6	1150	1600	1.7	0.50 ⁽¹⁰⁾
28F-2.1E SP ⁽⁷⁾	2800	2300	740	300	2.1 ⁽⁹⁾	1600	650	260	1.7	1250	1750	1.7	0.55
30F-2.1E SP ⁽⁷⁾⁽⁸⁾	3000	2400	740	300	2.1 ⁽⁹⁾	1750	650	260	1.7	1250	1750	1.7	0.55

Notes:

- (1) For balanced layups, F_{bx}^- shall be equal to F_{bx}^+ for the stress class. Designer shall specify when balanced layup is required.
- (2) Negative bending stress, F_{bx}^- , is permitted to be increased to 1850 psi for Douglas-fir and to 1950 psi for southern pine for specific combinations. Designer shall specify when these increased stresses are required.
- (3) For structural glued laminated timber of **southern pine**, the basic shear design values, F_{vx} and F_{vy} , are permitted to be increased to **300 psi**, and **260 psi**, respectively.
- (4) The design value for shear, F_{vx} , shall be decreased by multiplying by a factor of 0.72 for non-prismatic members, notched members, and for all members subject to impact or cyclic loading. The reduced design value shall be used for design of members at connections that transfer shear by mechanical fasteners. The reduced design value shall be used for determination of design values for radial tension and torsion.
- (5) Design values are for timbers with laminations made from a single piece of lumber across the width or multiple pieces that have been edge bonded. For timbers manufactured from multiple piece laminations (across width) that are not edge bonded, value shall be multiplied by 0.4 for members with 5, 7, or 9 laminations or by 0.5 for all other members. This reduction shall be cumulative with the adjustment in footnote 4.
- (6) Certain southern pine combinations may contain lumber with wane. If lumber with wane is used, the design value for shear parallel to grain, F_{vx} , shall be multiplied by 0.67 if wane is allowed on both sides. If wane is limited to one side, F_{vx} shall be multiplied by 0.83. This reduction shall be cumulative with the adjustment in footnote 4.
- (7) 26F, 28F, and 30F beams are not produced by all manufacturers, therefore, availability may be limited. Contact supplier or manufacturer for details.
- (8) 30F combinations are restricted to a maximum 6 in. nominal width.
- (9) For 28F and 30F members with more than 15 laminations, $E_x = 2.0$ million psi.
- (10) For structural glued laminated timber of southern pine, specific gravity for fastener design is permitted to be increased to 0.55.

Design values in this table represent design values for groups of similar glued laminated timber combinations. Higher design values for some properties may be obtained by specifying a particular combination in *Glulam Design Properties and Layup Combinations, Form EWS Y117*. Design values are for members with 4 or more laminations. Some stress classes are not available in all species. Contact manufacturer for availability.

For nonresidential applications, where long spans, unusually heavy loads, or other circumstances control design, custom members are typically specified. Common custom shapes include straight beams, curved beams, pitched and curved beams, radial arches and tudor arches.

Appearance Classification

Glulam is available in a range of appearances, all looking different but having the same structural characteristics for a given strength grade. Glulam appearance classifications are:

Framing. An EWS classification that denotes the member is intended only for use in concealed applications. Beams with this appearance classification are provided in widths designed to fit flush with 2x4 and 2x6 wall framing. **Framing-L** is the same as Framing but denotes that LVL has been used for the outer tension laminations.

Industrial. Used for concealed applications or where appearance is not of primary importance. **Industrial-L** is the same as Industrial but denotes that LVL has been used for outer tension laminations.

Architectural. The appearance of choice in applications where members are exposed to view, because they have a smooth, attractive finish. Stock beams are often supplied with this appearance so they may be exposed to view in the finished structure.

Premium. Available only as a custom order where finished appearance is of primary importance.

All appearance classifications permit natural growth characteristics with varying degrees of open voids permitted. Voids are filled as required by the appearance grade specified using inserts and wood fillers. The appearance classification is not related to lumber layup requirements and thus does not affect design values for the beam. For additional information, refer to [Engineered Wood Systems Technical Note: Glued Laminated Timber Appearance Classifications for Construction Applications, Form EWS Y110.](#)

Section Properties and Capacities

When selecting a glulam member, the builder, designer, or specifier must use a member with the required section properties to satisfy the load carrying requirements. Different load capacities are possible for different stress level combinations of glulam. Tables giving the load carrying capacities for glulam are included in the [Engineered Wood Systems Data File: Glued Laminated Beam Design Tables, Form EWS S475.](#)

Camber

Camber is curvature built into a fabricated member (see figure below) which is opposite in direction and magnitude to the calculated deflection which will occur under gravity loads.

The glulam industry recommends that roof beams be cambered for 1-1/2 times the calculated dead load deflection. This will generally be sufficient to assure that the beam will not exhibit a sag over a period of many years of loading, as may occur with non-cambered wood products. To achieve a level profile it is recommended that floor beams be only cambered for 1.0 times the calculated dead load deflection.

Camber for glulam beams is specified as either “inches of camber” or as a radius of curvature that is to be used in the manufacturing process. Commonly used curvature radii for commercial applications are 1,600 and 2,000 feet although any camber may be specified.

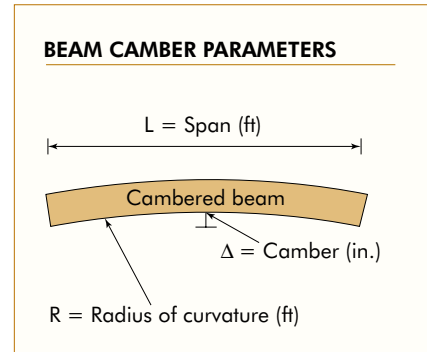

Most residential applications require very little or no camber which, in turn, makes glulam the ideal choice. Stock beams are typically supplied with a relatively flat camber radius of 3,500 feet as shown in Table 7, or zero camber.

TABLE 7
CAMBER FOR 3,500-FOOT RADIUS

Span in feet:	10	12	14	16	18	20	22	24	26	28
Camber in inches:	.04	.06	.08	.11	.14	.17	.21	.25	.29	.34

Thus, they have just the right camber for residential construction. If, however, more camber is required, such as for a long span roof beam, custom beams are available through manufacturers to meet the most exacting specifications.

For additional information on cambering glulam beams, refer to [Engineered Wood Systems Technical Note: Glulam Beam Camber, Form EWS S550,](#) which provides a camber table for various beam spans and radii of curvature.

Trademarks and Acceptances

Glulam beams manufactured by *Engineered Wood Systems* members are certified with the *APA EWS* trademark. The mark (as shown) signifies that the manufacturer is committed to a rigorous program of quality verification and testing and that products are manufactured in conformance with ANSI Standard A190.1-2002, American National Standard for Structural Glued Laminated Timber. The *APA EWS* trademark is recognized by all major model building codes.



The diagram shows the APA EWS trademark with the following text elements: **APA EWS** (top), **B IND** (left), **EWS Y117** (right), **EWS 24F-1.8E** (center), **WW** (right), **MILL 0000** (left), and **ANSI A190.1-2002** (right). Numbered callouts 1 through 7 point to these elements.

- 1 Indicates structural use: B-Simple span bending member. C-Compression member. T-Tension member. CB-Continuous or cantilevered span bending member.
- 2 Mill number.
- 3 Identification of ANSI Standard A190.1, Structural Glued Laminated Timber. ANSI A190.1 is the American National Standard for glulam beams.
- 4 Applicable laminating specification.
- 5 Western woods (see note 6).
- 6 Structural grade designation. The *APA EWS 24F-1.8E* designation is a glulam grade commonly used in residential applications. Combining a group of six layup combinations made with Douglas fir-larch, spruce-pine-fir, southern pine, and/or hem-fir, this grade provides strength (allowable bending stress of 2,400 psi and allowable shear stress of 215 psi) and stiffness (modulus of elasticity of 1.8×10^6 psi) needed for typical residential applications, while greatly simplifying the design specification.
- 7 Designation of appearance grade. FRAMING, FRAMING-L*, INDUSTRIAL, INDUSTRIAL-L*, ARCHITECTURAL, or PREMIUM.
*LVL used for tension laminations.

Typical information included in an *APA EWS* trademark is shown above. This information may vary depending on whether the member is supplied as a custom or stock product.

Glulam Beam Storage and Handling

APA EWS trademarked glued laminated beams (glulam) are commonly protected with sealants, primers or wrappings when they leave the mill. But care must be taken during loading, unloading and transporting as well as in the yard and on the job site.

Sealants on the ends of beams help guard against moisture penetration and checking. Apply a coat of sealant to the ends of beams after trimming. Surface sealants, which can be applied to the top, bottom and sides of beams, resist dirt and moisture and help control checking and grain raising. Use a penetrating sealant if beams will be stained or given a natural finish.

A primer coat also protects beams from moisture and dirt and provides a paintable surface.

Water-resistant wrappings are another way to protect beams from moisture, dirt and scratches. Because sunlight can discolor beams, opaque wrappings are recommended. Beams can be wrapped individually, by the bundle or by the load. In situations where appearance is especially important, the wrapping can be removed after installation to avoid damage.

If possible, store glulam under cover to protect them from rain and sunlight. Place the beams on spaced lumber bunks on level, well-drained ground. In some instances, the wrappings can be used to protect beams until installation. Again, seal ends of beams immediately after trimming. Once beams are installed, allow them to gradually season and adjust to the temperature and moisture conditions of the structure.

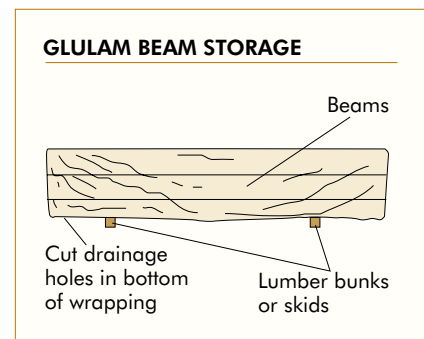

GLULAM SPECIFICATION GUIDE

The following is a guide for preparing specifications for structural glued laminated timber used for bending members such as purlins, beams, or girders or for axially loaded members such as columns or truss chords.

A. General

1. Structural glued laminated timber shall be furnished as shown on the plans and in accordance with the following specifications. (Where other uses or requirements are applicable, modify specifications accordingly.)

2. For custom designed members, shop drawings and details shall be furnished by the (manufacturer) (seller) and approval obtained from the (architect) (engineer) (general contractor) (buyer) before fabrication is begun.

3. The (manufacturer) (seller) (general contractor) shall furnish connection steel and hardware for joining structural glued laminated timber members to each other and to their supports, exclusive of anchorage embedded in masonry or concrete, setting plates, and items field-welded to structural steel. Steel connections shall be finished with one coat of rust-inhibiting paint.

B. Manufacture

1. Materials, Manufacture and Quality Assurance – Structural glued laminated timber of softwood species shall be in conformance with *ANSI Standard A190.1, American National Standard for Structural Glued Laminated Timber*, or other code-approved design, manufacturing and/or quality assurance procedures.

2. End-Use Application – Structural glued laminated timber members shall be manufactured for the following structural uses as applicable: (Simple span bending member – B) (continuous or cantilever span bending member – CB) (compression member – C) (tension member – T).

3. Design Values – Structural glued laminated timber shall provide design values for normal load duration and dry-use condition.⁽¹⁾⁽²⁾ The design should specify a layup combination from [Form EWS Y117](#) or specify a stress combination from [Table 6](#).

4. Appearance Grade – Glulam shall be (framing) (framing-L) (industrial) (industrial-L) (architectural) (premium) grade⁽³⁾ in accordance with ANSI Standard A190.1.

5. Laminating Adhesives – Adhesives used in the manufacture of structural glued laminated timber shall meet requirements for (wet-use) (dry-use) service conditions.⁽¹⁾

6. Camber (when applicable) – Structural glued laminated timber (shall) (shall not) be manufactured with a built-in camber.

7. Preservative Treatment (when applicable) – Glulam shall be pressure treated after manufacture in accordance with American Wood-Preservers' Association (AWPA) Standard C28 with (creosote or creosote/coal tar solution) (pentachlorophenol in oil) (pentachlorophenol in light solvent) preservatives as required for (soil contact) (above ground) exposure.

8. Fire Resistance (when applicable) – Glulam shall be sized and manufactured for one-hour fire resistance.⁽⁴⁾

9. Protective Sealers and Finishes – Unless otherwise specified, sealer shall be applied to the ends of all members. Surfaces of members shall be (not sealed) (sealed with penetrating sealer) (sealed with primer/sealer coating).⁽⁵⁾

10. Trademarks – Members shall be marked with the Engineered Wood Systems APA EWS trademark indicating conformance with the manufacturing, quality assurance and marking provisions of ANSI Standard A190.1.

11. Certificates (when applicable) – A Certificate of Conformance may be provided by the (manufacturer) (seller) to indicate conformance with ANSI Standard A190.1 if requested.

12. Protection for Shipment – Members shall be (not wrapped) (load wrapped) (bundle wrapped) (individually wrapped) with a water-resistant covering for shipment.

Notes to Specifiers:

- (1) Dry service condition – moisture content of the member will be below 16% in service; wet service condition – moisture content of the member will be at or above 16% in service. When structural glued laminated timber members are to be preservative treated, wet-use adhesives must be specified.
- (2) An alternative to specifying a layup combination or stress combination is to specify the required allowable design stresses for the specific design application.
- (3) Appearance classifications are described in [Engineered Wood Systems Technical Note EWS Y110, Glued Laminated Timber Appearance Classifications for Construction Applications](#).
- (4) When structural glued laminated timber with one-hour fire resistance is specified, minimum size limitations and additional lamination requirements are applicable. Supporting steel connectors and fasteners also must be protected to achieve a one-hour fire rating. Cover with fire-rated (Type X) gypsum wallboard or sheathing, or 1-1/2" wood, to provide the needed protection.
- (5) Specify a penetrating sealer when the finish will be natural or a semitransparent stain. Primer/sealer coatings have a higher solids content and provide greater moisture protection, and are suitable for use with opaque or solid-color finishes.

I-JOIST SELECTION AND SPECIFICATION

I-joists are “I”-shaped engineered wood structural members designed for use in residential and nonresidential construction. The product is prefabricated using sawn or structural composite lumber flanges and plywood or OSB webs, bonded together with exterior type adhesives. To simplify the specification and use of I-joists, APA introduced the APA Performance Rated I-Joist (PRI). The joist is limited to a L/480 live load maximum deflection (where L = span) for glued-nailed residential floor applications, a criteria which provides superior floor performance.

APA Performance Rated I-Joists are identified by their net depth followed by a designation such as PRI-30 which relates to the joist strength and stiffness. APA PRIs are available in four depths: 9-1/2, 11-7/8, 14, and 16 inches.

Most manufacturers supply I-joists to distributors and dealers in lengths up to 60 feet. These are then cut to frequently used lengths such as 16 to 36 feet. Check local supplier for availability.

APA PRI-400

APA PRIs are manufactured in accordance with [Performance Standard for APA EWS I-Joists, PRI-400](#). This Performance Standard provides an easy-to-use table of allowable spans for applications in residential floor construction, allowing designers and builders to select and use I-joists from various member manufacturers using just one set of span tables.

Residential Floor Spans

Some APA PRIs include in their trademarks allowable spans for uniformly loaded residential floor construction at various I-joist spacings. The specific I-joist needed is easily determined by selecting the span and then choosing the I-joist that meets the span, spacing, and loading criteria. [See Tables 8 and 9](#).

TABLE 8

ALLOWABLE SPANS FOR APA EWS PERFORMANCE RATED I-JOISTS – SIMPLE SPAN ONLY

Depth	Joist Designation	Simple Span On Center Spacing			
		12"	16"	19.2"	24"
9-1/2"	PRI-20	16'-7"	15'-2"	14'-4"	13'-5"
	PRI-30	17'-1"	15'-8"	14'-10"	13'-10"
	PRI-40	18'-0"	16'-5"	15'-6"	14'-6"
	PRI-50	17'-10"	16'-4"	15'-5"	14'-5"
	PRI-60	18'-11"	17'-4"	16'-4"	15'-3"
11-7/8"	PRI-20	19'-10"	18'-2"	17'-2"	16'-0"
	PRI-30	20'-6"	18'-9"	17'-8"	16'-6"
	PRI-40	21'-5"	19'-7"	18'-6"	16'-8"
	PRI-50	21'-4"	19'-6"	18'-5"	17'-2"
	PRI-60	22'-7"	20'-8"	19'-6"	18'-2"
	PRI-70	23'-0"	21'-0"	19'-10"	18'-6"
	PRI-80	24'-11"	22'-8"	21'-4"	19'-10"
	PRI-90	25'-8"	23'-4"	22'-0"	20'-5"
14"	PRI-40	24'-4"	22'-3"	20'-6"	18'-4"
	PRI-50	24'-4"	22'-2"	21'-0"	19'-7"
	PRI-60	25'-9"	23'-6"	22'-2"	20'-8"
	PRI-70	26'-1"	23'-10"	22'-6"	20'-11"
	PRI-80	28'-3"	25'-9"	24'-3"	22'-7"
	PRI-90	29'-1"	26'-5"	24'-11"	23'-2"
16"	PRI-40	26'-11"	24'-3"	22'-1"	19'-9"
	PRI-50	27'-0"	24'-8"	23'-4"	20'-2"
	PRI-60	28'-6"	26'-0"	24'-7"	22'-10"
	PRI-70	29'-0"	26'-5"	24'-11"	23'-1"
	PRI-80	31'-4"	28'-6"	26'-10"	25'-0"
	PRI-90	32'-2"	29'-3"	27'-7"	25'-7"

Notes:

1. Allowable **clear** span applicable to simple-span residential floor construction with a design dead load of 10 psf and live load of 40 psf. The live load deflection is limited to span/480.
2. Spans are based on a composite floor with glued-nailed sheathing meeting the requirements for APA Rated Sheathing or APA Rated STURD-I-FLOOR conforming to PRP-108, PS 1, or PS 2 with a minimum thickness of 19/32 inch (40/20 or 20 oc) for a joist spacing of 19.2 inches or less, or 23/32 inch (48/24 or 24 oc) for a joist spacing of 24 inches. Adhesive shall meet APA Specification AFG-01 or ASTM D3498. Spans shall be reduced 1 foot when the floor sheathing is nailed only.
3. Minimum bearing length shall be 1-3/4 inches for the end bearings.
4. Bearing stiffeners are **not** required when I-joists are used with the spans and spacings given in this table, except as required for hangers.
5. This span chart is based on uniform loads. For applications with other than uniformly distributed loads, an engineering analysis may be required based on the use of the design properties in Table 7 of [APA Performance Rated I-Joists, Form Z725](#).

TABLE 9

ALLOWABLE SPANS FOR APA EWS PERFORMANCE RATED I-JOISTS – MULTIPLE SPAN ONLY

Depth	Joist Designation	Multiple Span On Center Spacing				Notes:
		12"	16"	19.2"	24"	
9-1/2"	PRI-20	18'-1"	16'-6"	15'-7"	13'-5"	Notes: 1. Allowable clear span applicable to multiple-span residential floor construction with a design dead load of 10 psf and live load of 40 psf. The end spans shall be 40% or more of the adjacent span. The live load deflection is limited to span/480. 2. Spans are based on a composite floor with glued-nailed sheathing meeting the requirements for APA Rated Sheathing or APA Rated STURD-I-FLOOR conforming to PRP-108, PS 1, or PS 2 with a minimum thickness of 19/32 inch (40/20 or 20 oc) for a joist spacing of 19.2 inches or less, or 23/32 inch (48/24 or 24 oc) for a joist spacing of 24 inches. Adhesive shall meet APA Specification AFG-01 or ASTM D3498. Spans shall be reduced 1 foot when the floor sheathing is nailed only. 3. Minimum bearing length shall be 1-3/4 inches for the end bearings, and 3-1/2 inches for the intermediate bearings. 4. Bearing stiffeners are not required when I-joists are used with the spans and spacings given in this table, except as required for hangers. 5. This span chart is based on uniform loads. For applications with other than uniformly distributed loads, an engineering analysis may be required based on the use of the design properties in Table 7 of APA Performance Rated I-Joists, Form Z725 .
	PRI-30	18'-7"	17'-0"	16'-1"	15'-0"	
	PRI-40	19'-7"	17'-11"	16'-4"	14'-7"	
	PRI-50	19'-5"	17'-9"	16'-9"	15'-7"	
	PRI-60	20'-8"	18'-10"	17'-9"	16'-6"	
11-7/8"	PRI-20	21'-8"	19'-7"	16'-9"	13'-5"	
	PRI-30	22'-4"	20'-5"	18'-10"	15'-0"	
	PRI-40	23'-5"	20'-5"	18'-7"	16'-7"	
	PRI-50	23'-3"	21'-2"	20'-0"	16'-1"	
	PRI-60	24'-8"	22'-6"	21'-2"	19'-7"	
	PRI-70	25'-1"	22'-10"	21'-7"	18'-6"	
	PRI-80	27'-1"	24'-8"	23'-3"	21'-7"	
PRI-90	27'-11"	25'-5"	23'-11"	22'-2"		
14"	PRI-40	25'-11"	22'-5"	20'-5"	18'-3"	
	PRI-50	26'-6"	24'-2"	20'-2"	16'-1"	
	PRI-60	28'-0"	25'-7"	24'-1"	19'-9"	
	PRI-70	28'-5"	25'-11"	23'-2"	18'-6"	
	PRI-80	30'-10"	28'-0"	26'-5"	23'-11"	
PRI-90	31'-8"	28'-10"	27'-1"	25'-2"		
16"	PRI-40	27'-11"	24'-2"	22'-0"	19'-8"	
	PRI-50	29'-6"	24'-3"	20'-2"	16'-1"	
	PRI-60	31'-1"	28'-4"	24'-9"	19'-9"	
	PRI-70	31'-7"	27'-10"	23'-2"	18'-6"	
	PRI-80	34'-2"	31'-1"	29'-3"	23'-11"	
PRI-90	35'-1"	31'-10"	30'-0"	26'-7"		

For more information on selecting APA I-joists, and for design tables, refer to [APA Performance Rated I-Joists, Form Z725](#), available on APA's web site at www.apawood.org.

APA Performance Rated Rim Board

See [page 31](#) for a description of APA Performance Rated Rim Board.

I-Joist Storage and Handling

Store, stack and handle I-joists vertically, and try to keep joists level. Do not store I-joists in direct contact with the ground. Protect I-joists from weather, and use stickers to separate the bundles. If I-joists are delivered wrapped, do not open bundles until time of installation.

When handling I-joists with a crane on the job site ("picking"), take a few simple precautions to prevent damage to the joists and injury to the work crew: pick I-joists in bundles as shipped by the supplier; orient the bundles so that the webs of the I-joists are vertical; and pick the bundles using a spreader bar if necessary. Do not twist or apply loads to the I-joists when they are horizontal. Never use or try to repair a damaged I-joist.

I-joists are not stable until completely installed, and will not carry any load until fully braced and sheathed. Do not allow workers to walk on joists until the joists are fully installed and braced. To avoid accidents, brace and nail each I-joist as it is installed, using hangers, blocking panels, rim board, and/or cross-bridging at joist ends and over each support. For additional storage and handling recommendations, refer to the [Builder Tip: Storage, Handling and Safety Recommendations for APA Performance Rated I-Joists, Form Z735](#).

APA PERFORMANCE RATED I-JOIST SPECIFICATION GUIDE

The following is a guide for specifying APA Performance Rated I-Joists (PRI) to be used in residential floor applications. These structural products are available in net depths of 9-1/2 inches, 11-7/8 inches, 14 inches, and 16 inches, and can be used for simple- or multiple-span floor construction. Exterior use, or use of wood I-joists in other than protected dry conditions, is not recommended.

A. General

1. APA PRIs shall be furnished and installed as shown by the approved building plans and installation instructions.
2. The designation of APA PRI shall be based on the applicable loading, joist spacing and spans shown in the plans. PRIs may be selected using [Tables 1 and 2 of APA Performance Rated I-Joists, Form Z725](#). For non-uniform loading conditions requiring an engineering analysis, see Table 7 of the above-mentioned guide for PRI joist design properties.

The specification for I-joists required for a specific floor application shall include joist depth, designation, length, and number of pieces required.

*Example: 21 pieces –
APA 9-1/2" PRI-30 x 30 feet long*

3. All accessory products such as I-joist blocking panels, rim boards, squash blocks, web stiffeners, etc., shall be provided and installed in accordance with the applicable installation details shown in [Form Z725](#).
4. APA EWS trademarked glued-laminated timber (glulam) or approved structural composite lumber (SCL) shall be furnished for load-bearing joist headers. The depth of these components shall be specified to match the I-joist depth when flush framing is required.
5. The contractor shall use approved connection hardware (joist hangers) as specified in the plans. Such hardware shall be compatible with the width and depth of APA PRIs furnished, to provide flush nailing surfaces at adjoining members and to prevent rotation.

B. Manufacture

1. Materials, Manufacture, and Quality Assurance. Product quality shall conform to the manufacturer's approved quality control manual, with compliance assurance services provided by APA in accordance with building code requirements and the applicable code evaluation report.

2. Trademarks. I-joists shall be marked with the APA EWS trademark indicating conformance with the manufacturing, quality assurance, and marking provisions of [APA EWS Standard PRI-400, Performance Standard for APA EWS I-Joists](#) or the applicable manufacturer's code evaluation report.

3. Jobsite Shipment. I-joists shall be protected from direct exposure to weather prior to installation.

LVL SELECTION AND SPECIFICATION

Laminated veneer lumber (LVL) is an engineered wood product created by bonding dried and graded wood veneers with exterior type adhesives into long solid blocks known as billets, which are subsequently resawn into specified sizes. Because it is made with scarfed or lapped jointed veneers, LVL is available in lengths far beyond conventional lumber lengths. LVL is available in a variety of thicknesses with the most common being 1-3/4", and in various widths. It is easily sawn and fastened in the field using conventional construction tools and methods. Because LVL generally has the grain of all the veneers running in the long direction, rather than as cross-laminations as with engineered wood products like plywood, it has high strength in the long direction. The design strength properties for LVL generally exceed those of conventional lumber grades, and variability is lower due to greater dispersion of natural growth characteristics of the wood.

Typical uses for LVL include rafters, headers, beams, joists, studs, and columns. Two or three sections of LVL can be joined together to form 3-1/2" or 5-1/4" members. These thicker sections readily nest into 2x4 or 2x6 framed walls as headers or columns.

Allowable Strength Properties

Structural properties of LVL are evaluated using methods specified in ASTM Standard Specification D5456 for Structural Composite Lumber. Ongoing quality auditing of LVL is performed by APA. The structural design values for LVL are published on a proprietary basis by manufacturers of LVL and are recognized in their evaluation reports published by model code agencies. [A list of APA EWS LVL manufacturers](#) is available on APA's web site (www.apawood.org).

LAMINATED VENEER LUMBER (LVL) SPECIFICATION GUIDE

A. General

1. LVL shall be furnished and installed as shown on the approved building plans and in accordance with the specifications of the LVL manufacturer.
2. The contractor shall use approved hardware and connections as specified in the plans.

B. Manufacture

1. **Materials, Manufacture and Quality Assurance.** Product quality shall conform to the manufacturer's approved quality control manual, with certification services provided by APA EWS in accordance with building code requirements and the applicable code evaluation report.

2. **Trademarks.** LVL shall be marked with the APA EWS trademark, indicating conformance with the manufacturer's evaluation report.

3. **Jobsite Shipment.** LVL shall be protected from direct exposure to weather prior to installation.



FLOOR CONSTRUCTION

APA Rated Sturd-I-Floor®

APA RATED STURD-I-FLOOR is a span-rated APA proprietary product designed specifically for use in single-layer floor construction beneath carpet and pad. The product provides all of the proven cost-saving and performance benefits of combined subfloor-underlayment construction. It is manufactured in conformance with [APA PRP-108 Performance Standards](#) and/or [Voluntary Product Standard PS 1](#) or [PS 2](#). It's easy to use and specify because the maximum recommended spacing of floor joists – or Span Rating – is stamped on each panel. Panels are manufactured with Span Ratings of 16, 20, 24, 32 and 48 inches. **These assume use of the panel continuous over two or more spans with the long dimension or strength axis across supports.***

Glue-nailing is recommended for STURD-I-FLOOR panels, though panels may be nailed only. Recommendations for both methods are given in [Table 10](#). (See “[The APA Glued Floor System](#),” page 32, for more detailed gluing recommendations.) Always protect smooth panel faces and tongue-and-groove edges from damage prior to and during application. Install with smooth side up. Recommended live loads are given in [Table 11](#).

If long-term exposure to the weather is required, specify Exterior panels.



*Note: The Span Rating in the trademark applies when the long panel dimension or strength axis is across supports unless the strength axis is otherwise identified.

FIGURE 1

APA RATED STURD-I-FLOOR 16, 20, AND 24 oc

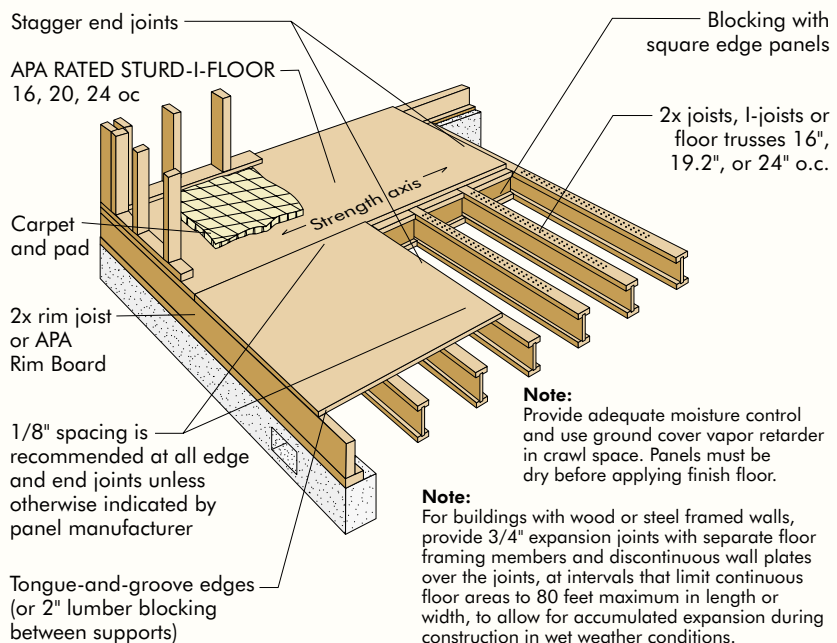

Although STURD-I-FLOOR is suitable for direct application of carpet and pad, an additional thin layer of underlayment is recommended under tile, sheet flooring or fully adhered carpet. This added layer restores a smooth surface over panels that may have been scuffed or roughened during construction, or over panels that may not have received a sufficiently sanded surface. When veneer-faced STURD-I-FLOOR with “sanded face” is specified, the surface is also suitable for direct application of resilient floor covering. Glued T&G edges are recommended under thin floor coverings to assure snug joints.

TABLE 10

APA RATED STURD-I-FLOOR^(a)

Span Rating (Maximum Joist Spacing) (in.)	Panel Thickness ^(b) (in.)	Fastening: Glue-Nailed ^(c)			Fastening: Nailed-Only		
		Nail Size and Type ⁽ⁱ⁾	Maximum Spacing (in.) ^(h)		Nail Size and Type ⁽ⁱ⁾	Maximum Spacing (in.) ^(h)	
			Supported Panel Edges ^(g)	Intermediate Supports		Supported Panel Edges ^(g)	Intermediate Supports
16	19/32, 5/8	6d ring- or screw-shank ^(d)	12	12	6d ring- or screw-shank	6	12
20	19/32, 5/8	6d ring- or screw-shank ^(d)	12	12	6d ring- or screw-shank	6	12
24	23/32, 3/4	6d ring- or screw-shank ^(d)	12	12	6d ring- or screw-shank	6	12
	7/8	8d ring- or screw-shank ^(d)	6	12	8d ring- or screw-shank	6	12
32	7/8	8d ring- or screw-shank ^(d)	6	12	8d ring- or screw-shank	6	12
48	1-3/32, 1-1/8	8d ring- or screw-shank ^(e)	6	(f)	8d ring- or screw-shank ^(e)	6	(f)

(a) Special conditions may impose heavy traffic and concentrated loads that require construction in excess of the minimums shown. See page 39 for heavy duty floor recommendations.

(b) Panels in a given thickness may be manufactured in more than one Span Rating. Panels with a Span Rating greater than the actual joist spacing may be substituted for panels of the same thickness with a Span Rating matching the actual joist spacing. For example, 19/32-inch-thick Sturd-I-Floor 20 oc may be substituted for 19/32-inch-thick Sturd-I-Floor 16 oc over joists 16 inches on center.

(c) Use only adhesives conforming to APA Specification AFG-01 or ASTM D3498, applied in accordance with the adhesive manufacturer’s recommendations. If OSB panels with sealed surfaces and edges are to be used, use only solvent-based glues; check with panel manufacturer.

(d) 8d common nails may be substituted if ring- or screw-shank nails are not available.

(e) 10d common nails may be substituted with 1-1/8-inch panels if supports are well seasoned.

(f) Space nails maximum 6 inches for 48-inch spans and 12 inches for 32-inch spans.

(g) Supported panel joints shall occur approximately along the centerline of framing with a minimum bearing of 1/2 inch. Fasten panels 3/8 inch from panel edges.

(h) Increased nail schedules may be required where floor is engineered as a diaphragm.

(i) See Table 5 for nail dimensions.

TABLE 11

RECOMMENDED UNIFORM FLOOR LIVE LOADS FOR APA RATED STURD-I-FLOOR AND APA RATED SHEATHING WITH STRENGTH AXIS PERPENDICULAR TO SUPPORTS

Sturd-I-Floor Span Rating	Sheathing Span Rating	Minimum Panel Thickness (in.)	Maximum Span (in.)	Allowable Live Loads (psf) ^(a)							
				Joist Spacing (in.)							
				12	16	20	24	32	40	48	
16 oc	24/16, 32/16	7/16 ^(c)	16	185	100						
20 oc	40/20	19/32, 5/8	20	270	150	100					
24 oc	48/24	23/32, 3/4	24	430	240	160	100				
32 oc	60/32 ^(b)	7/8	32		430	295	185	100			
48 oc		1-3/32, 1-1/8	48			460	290	160	100	100	55

(a) 10 psf dead load assumed. Live load deflection limit is l/360.

(c) 19/32 inch is minimum thickness of Rated Sturd-I-Floor.

(b) Check with supplier for availability.

If the floor has become wet during construction, it should be allowed to dry before application of finish floor, including carpet, underlayment, hardwood flooring, ceramic tile, etc. After it is dry, the floor should be checked for flatness, especially at joints.

When floor members are dry, make sure fasteners are flush with or slightly below surface of the STURD-I-FLOOR panels just prior to installation of thin floor coverings. Fasteners should be set if green framing will present nail popping problems upon drying. **Do not** fill nail holes. Fill and thoroughly sand edge joints (this step may not be necessary under some carpet and structural flooring products – check recommendations of flooring manufacturer). Fill any other damaged or open areas, such as splits, and sand all surface roughness.

Sturd-I-Floor 32 oc and 48 oc

Install APA RATED STURD-I-FLOOR 48 oc or 32 oc panels over 2x joists or I-joists spaced 32 inches on center (Figure 2). Install APA RATED STURD-I-FLOOR 48 oc over 4x girders 48 inches on center (Figure 3). For the 48 oc method, supports may be 2x joists spiked together, 4x lumber, glued laminated timber (glulams), lightweight steel beams, or wood I-joists or floor trusses. Girders of doubled 2x members should have top edges flush to permit smooth panel end joints.

For a low profile with supports 48 inches on center, beams can be set in foundation pockets or on posts supported by footings so that panels bear directly on the sill. If 4x lumber girders are used, they should be air dried and/or set higher than the sill to allow for shrinkage.

In some applications, particularly in hallways and other heavy traffic areas, greater stiffness in the floor may be desirable. Modifications to the 48-inch framing system, such as addition of straight or diagonal blocking, will increase stiffness considerably.

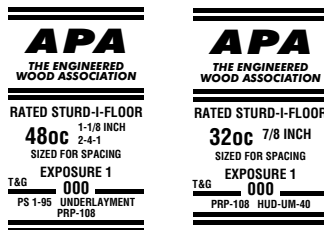
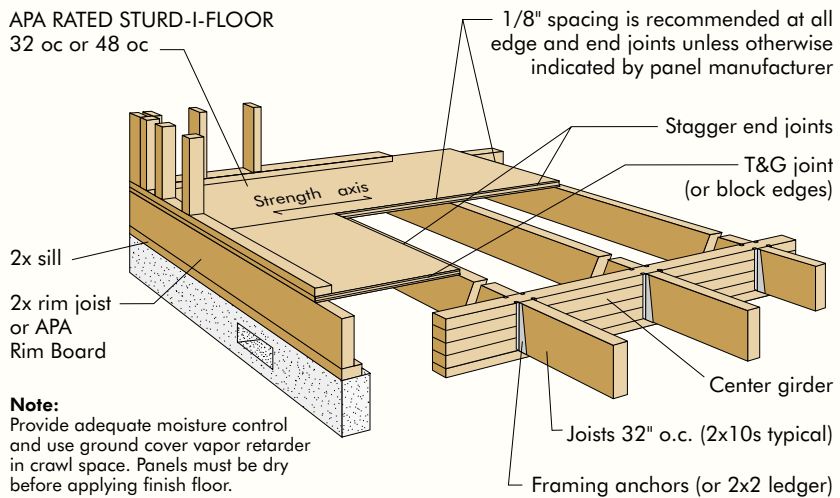

FIGURE 2

APA RATED STURD-I-FLOOR 32 oc AND 48 oc (Over Supports 32" o.c.)



Note:
Provide adequate moisture control and use ground cover vapor retarder in crawl space. Panels must be dry before applying finish floor.

Note:
For buildings with wood or steel framed walls, provide 3/4" expansion joints with separate floor framing members and discontinuous wall plates over the joints, at intervals that limit continuous floor areas to 80 feet maximum in length or width, to allow for accumulated expansion during construction in wet weather conditions.

FIGURE 3

APA RATED STURD-I-FLOOR 48 oc (Over Supports 48" o.c.)

1/8" spacing is recommended at all edge and end joints unless otherwise indicated by panel manufacturer

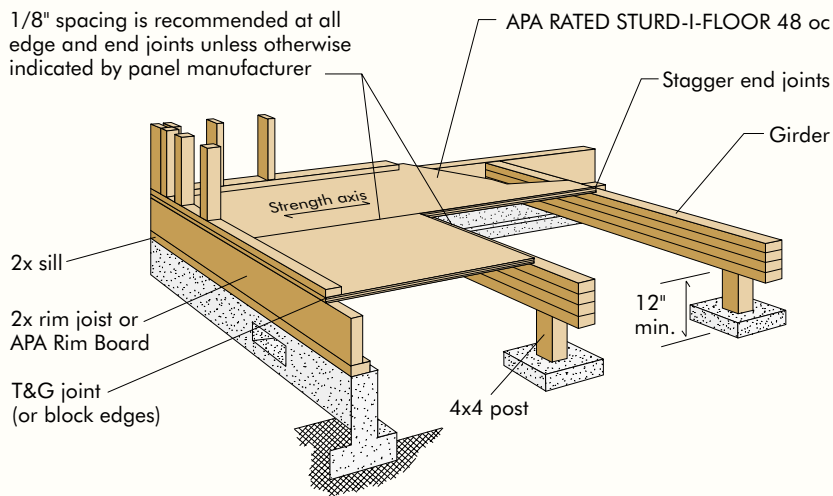
**Note:**

For buildings with wood or steel framed walls, provide 3/4" expansion joints with separate floor framing members and discontinuous wall plates over the joints, at intervals that limit continuous floor areas to 80 feet maximum in length or width, to allow for accumulated expansion during construction in wet weather conditions.

Note:

Provide adequate moisture control and use ground cover vapor retarder in crawl space. Panels must be dry before applying finish floor.

APA Performance Rated Rim Board

A rim board is the wood component that fills the space between the sill plate and bottom plate of a wall or, in second floor construction, between the top plate and bottom plate of two wall sections. The rim board must match the depth of the framing members between floors or between the floor and foundation to function properly. In addition to supporting the wall loads, the rim board ties the floor joists together. It is an integral component in an engineered wood system because it transfers both lateral and vertical bearing forces.

While lumber has been the traditional product used for rim boards, it is not compatible with the new generation of wood I-joists used in floor construction. With the increasing use of wood I-joists, a demand for compatible engineered wood rim boards has resulted.

APA Performance Rated Rim Boards can be manufactured using plywood, oriented strand board (OSB), glulam, or laminated veneer lumber (LVL). These engineered wood rim boards have less shrinkage than lumber and match the depth of wood I-joists and other engineered wood framing products. They are available in lengths up to 24 feet, depending on the product used.

Most APA Performance Rated Rim Boards are wood structural panels that are manufactured in accordance with the [Performance Standard for APA EWS Rim Boards](#) and [Voluntary Product Standards PS 1](#) or [PS 2](#), or [APA Standard PRP-108](#). Glulam rim boards are a resawn grade of glued laminated timber manufactured in accordance with the [Performance Standard for APA EWS Rim Boards](#) and [ANSI A190.1](#). The [Performance Standard for APA EWS Rim Boards](#) meets or exceeds the requirements given in the [ICC ES Acceptance Criteria for Wood-Based Rim Board Products](#), AC124.

As glued engineered wood products, APA Rim Boards have greater dimensional stability, higher strength, increased structural reliability, more consistent quality and a lower tendency to check or split than sawn lumber.



The APA Glued Floor System

The APA Glued Floor System is based on thoroughly tested gluing techniques and field-applied construction adhesives that firmly and permanently secure a layer of wood structural panels to wood joists. The glue bond is so strong that floor and joists behave like integral T-beam units. Floor stiffness is increased appreciably over conventional construction, particularly when tongue-and-groove joints are glued. Gluing also helps eliminate squeaks, floor vibration, bounce and nail-popping.

Field-glued floors go down quickly, even in cold weather, using ordinary construction materials and techniques. And like many other panel assemblies that provide excellent sound control, the APA Glued Floor System is ideal for multifamily construction. The large panels with glued tongue-and-groove joints reduce the number of cracks that can “leak” airborne noise.

The system is normally built with span-rated STURD-I-FLOOR panels (Figure 4), although double-layer floors are also applicable. **In both cases, STURD-I-FLOOR and subflooring panels should be installed continuous over two or more spans with the long dimension or strength axis across supports.**

Panels recommended for glued floor construction are tongue-and-groove APA RATED STURD-I-FLOOR for single-floor construction, and APA RATED SHEATHING for the subfloor when used with a separate underlayment or with structural finish flooring. (An additional layer of underlayment, or veneer-faced STURD-I-FLOOR with “sanded face” should be applied in areas to be finished with resilient floor coverings such as tile, linoleum, vinyl or fully adhered carpet.) Exposure 1 or Exterior should be specified for applications subject to moisture during or after construction, as in bathrooms and utility rooms.

Tongue-and-groove panels are highly recommended for single-floor construction. Before each panel is placed, a line of glue is applied to the joists with a caulking gun. The panel T&G joint should also be glued, although less heavily to avoid squeeze-out. If square-edge panels are used, edges must be supported between joists with 2x4 blocking. Glue panels to blocking to minimize squeaks. Blocking is not required under structural finish flooring, such as wood strip flooring, or if a separate underlayment is installed.

FIGURE 4
APA GLUED FLOOR SYSTEM

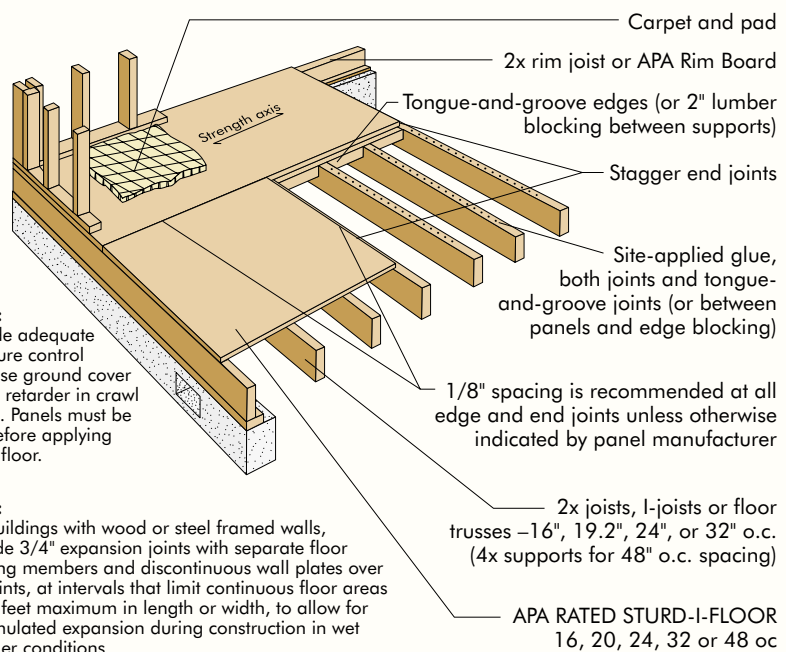

Note: Provide adequate moisture control and use ground cover vapor retarder in crawl space. Panels must be dry before applying finish floor.

Note: For buildings with wood or steel framed walls, provide 3/4" expansion joints with separate floor framing members and discontinuous wall plates over the joints, at intervals that limit continuous floor areas to 80 feet maximum in length or width, to allow for accumulated expansion during construction in wet weather conditions.

Only adhesives conforming with Performance Specification AFG-01 developed by APA or ASTM D3498 are recommended for use with the Glued Floor System. A number of brands meeting this specification are available from building supply dealers. **If OSB panels with sealed surfaces and edges are to be used, use only solvent-based glues; check with panel manufacturer.** Always follow the specific application recommendations of the glue manufacturer.

Application

For best results, follow these application procedures:

1. Snap a chalk line across joists four feet in from wall for panel edge alignment and as a boundary for spreading glue.
2. Spread only enough glue to lay one or two panels at a time or follow specific recommendations of glue manufacturer. Wipe any mud, dirt or water from joists before gluing.
3. Lay first panel with tongue side to wall and nail in place. This protects the tongue of next panel from damage when tapped into place with block and sledgehammer.
4. Apply a continuous line of glue (about 1/4-inch diameter) to framing members. Apply glue in a serpentine pattern on wide areas.
5. Apply two lines of glue on joists where panel ends butt to assure proper gluing of each end.
6. After first row of panels is in place, spread glue in groove of one or two panels at a time before laying next row. Glue line may be continuous or spaced, but avoid squeeze-out by applying a thinner line (1/8 inch) than on joists.
7. Tap second-row panels into place, using a block to protect groove edges.
8. Stagger end joints in each succeeding row. A 1/8-inch space between all end joints and 1/8 inch at all edges, including T&G, is recommended. (Use a spacer tool to assure accurate and consistent spacing.)
9. **Complete all nailing of each panel before glue sets.** (See [Table 10](#).) Check the glue manufacturer's recommendations for allowable time. (Warm weather accelerates glue setting.) Use 6d ring- or screw-shank nails for panels 3/4-inch-thick or less, and 8d ring- or screw-shank nails for thicker panels. See [Table 5](#) for nail dimensions. Space nails per [Table 10](#). Closer nail spacing may be required for diaphragm construction. Finished deck can be walked on and will carry construction loads without damage to glue bond.

APA Panel Subflooring

The limiting factor in the design of floors is deflection under concentrated loads at panel edges. The Span Ratings in [Table 12](#) apply to APA RATED SHEATHING grades only, and are the minimum recommended for the spans indicated. **The spans assume panels continuous over two or more spans with the long dimension or strength axis across supports.***

Recommended live loads are given in [Table 11](#). Spans are limited to the values shown because of the possible effect of concentrated loads.

Nailing recommendations are given in [Table 12](#). Other code-approved fasteners may be used. APA panel subflooring may also be glued for added stiffness and to reduce squeaks using nailing recommendations in [Table 10](#).

***Note:** The Span Rating in the trademark applies when the long panel dimension or strength axis is across supports unless the strength axis is otherwise identified.

Long edges should be tongue-and-groove or supported with blocking unless:

1. A separate underlayment layer is installed with its joints offset from those in the subfloor. The minimum thickness of underlayment should be 1/4 inch for subfloors on spans up to 24 inches and 11/32 inch or thicker panels on spans greater than 24 inches.
2. A minimum of 1-1/2 inches of lightweight concrete is applied over the panels.
3. 3/4-inch wood strip flooring is installed over the subfloor perpendicular to the unsupported edge.

If floor has become wet during construction, it should be allowed to dry before application of finish floor, including underlayment, hardwood flooring, ceramic tile, etc. After it is dry, the floor should be checked for flatness, especially at joints.

TABLE 12

APA PANEL SUBFLOORING (APA RATED SHEATHING)^{(a)(b)}

Panel Span Rating	Panel Thickness (in.)	Maximum Span (in.)	Nail Size & Type ^{(e)(h)}	Maximum Nail Spacing (in.)	
				Supported Panel Edges ^(g)	Intermediate Supports
24/16	7/16	16	6d common	6	12
32/16	15/32, 1/2	16	8d common ^(c)	6	12
40/20	19/32, 5/8	20 ^(d)	8d common	6	12
48/24	23/32, 3/4	24	8d common	6	12
60/32 ^(f)	7/8	32	8d common	6	12

(a) For subfloor recommendations under ceramic tile, refer to Table 14. For subfloor recommendations under gypsum concrete, contact manufacturer of floor topping.

(b) APA RATED STURD-I-FLOOR may be substituted when the Span Rating is equal to or greater than tabulated maximum span.

(c) 6d common nail permitted if panel is 1/2 inch or thinner.

(d) Span may be 24 inches if a minimum 1-1/2 inches of lightweight concrete is applied over panels.

(e) Other code-approved fasteners may be used.

(f) Check with supplier for availability.

(g) Supported panel joints shall occur approximately along the centerline of framing with a minimum bearing of 1/2". Fasteners shall be located 3/8 inch from panel edges.

(h) See Table 5 for nail dimensions.

FIGURE 5

APA PANEL SUBFLOORING

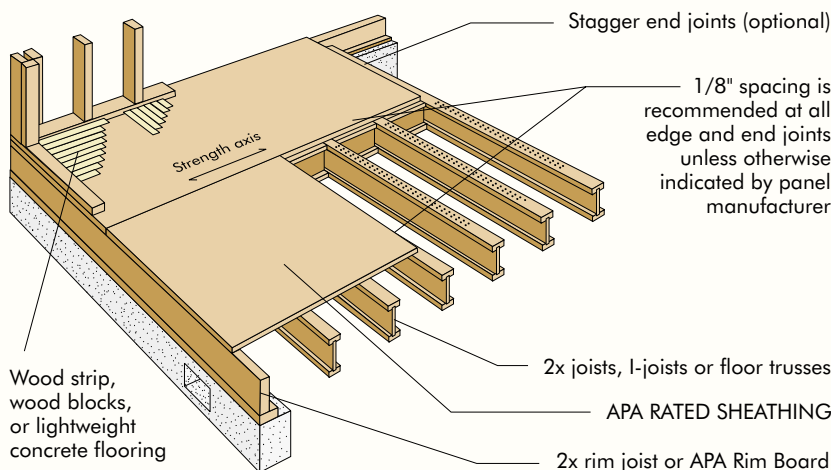

Note:
Provide adequate moisture control and use ground cover vapor retarder in crawl space. Subfloor must be dry before applying subsequent layers.

Note:
For buildings with wood or steel framed walls, provide 3/4" expansion joints with separate floor framing members and discontinuous wall plates over the joints, at intervals that limit continuous floor areas to 80 feet maximum in length or width, to allow for accumulated expansion during construction in wet weather conditions.

APA RATED SHEATHING Exposure 1 may be used where temporary exposure to moisture or the weather is expected during construction. However, only Exterior panels should be used where long-term exposure to moisture or the weather will be required.

In some nonresidential buildings, greater traffic and heavier concentrated loads may require construction in excess of the minimums given. Where joists are 16 inches on center, for example, panels with a Span Rating of 40/20 or 48/24 will give additional stiffness. For beams or joists 24 or 32 inches on center, 1-1/8-inch panels provide additional stiffness.

Lightweight Concrete Over APA Panels

APA RATED SHEATHING or STURD-I-FLOOR panels are an excellent base for lightweight concrete floors. See [“APA Rated Sturd-I-Floor,” page 28](#), or [“APA Panel Subflooring,” page 33](#), for application recommendations. For gypsum concrete recommendations, contact manufacturer of floor topping. **Install panels continuous over two or more spans with the strength axis across supports.** Use a moisture barrier when recommended by concrete manufacturer. (See [“Noise Transmission Control,” page 68](#), and [Figure 35](#) for an illustration of a typical assembly.)

APA Plywood Underlayment

Underlayment grades of plywood have a solid, touch-sanded surface for direct application of carpet and pad. For areas to be covered with resilient floor covering, specify panels with “sanded face,” or certain other grades as noted in [Table 13](#). Special inner-ply construction of Underlayment resists dents and punctures from concentrated loads. Applied as recommended, plywood underlayment is also dimensionally stable and eliminates excessive swelling and subsequent buckling or humps around nails.

Always protect plywood underlayment against physical damage or water prior to application. Panels should, however, be allowed to equalize to atmospheric conditions by standing individual panels on edge for several days before installation.

Install plywood underlayment, smooth side up, immediately before laying the finish floor. For maximum stiffness, place face grain across supports. End and edge joints of underlayment panels should be offset by at least two inches from joints of subfloor panels, and should not coincide with framing below.

Begin fastening at one edge next to a preceding panel. Assuring that the panel is uniformly flat, continue by fully fastening toward opposite edge. Make sure fasteners are flush with or just slightly below surface of Underlayment just prior to installation of resilient floor coverings such as tile, or sheet vinyl (see [Table 13](#) for underlayment recommendations for thin flooring products). Fill and thoroughly sand edge joints (this step may not be necessary under some carpet and structural flooring products – check recommendations of flooring manufacturer). Fill any other damaged or open areas, such as splits, and sand all surface roughness.

The plywood underlayment needed to bridge an uneven floor will depend on roughness and loads applied. Although a minimum 11/32-inch thickness is recommended, 1/4-inch plywood underlayment may also be acceptable over smooth subfloors, especially in remodeling work. (See [Table 13](#).)

Where floors may be subject to temporary moisture, use panels with exterior glue (Exposure 1) or APA C-C PLUGGED Exterior. APA C-D PLUGGED is not an adequate substitute for Underlayment grade since it does not ensure equivalent dent resistance.

TABLE 13

APA PLYWOOD UNDERLAYMENT^(c)

Plywood Grades ^(a)	Application	Minimum Plywood Thickness (in.)	Fastener Size and Type ^(f)	Maximum Fastener Spacing (in.) ^(e)	
				Panel Edges ^(d)	Intermediate
APA UNDERLAYMENT APA C-C Plugged EXT APA RATED STURD-I-FLOOR	Over smooth subfloor	1/4	3d x 1-1/4-in. ring-shank nails ^(b)	3	6 each way
(19/32" or thicker)	Over lumber subfloor or uneven surfaces	11/32	min. 12-1/2 gage (0.099 in.) shank dia.	6	8 each way

(a) In areas to be finished with resilient floor coverings such as tile or sheet vinyl, or with fully adhered carpet, specify Underlayment, C-C Plugged or veneer-faced STURD-I-FLOOR with "sanded face." Underlayment A-C, Underlayment B-C, Marine EXT or sanded plywood grades marked "Plugged Crossbands Under Face," "Plugged Crossbands (or Core)," "Plugged Inner Plies" or "Meets Underlayment Requirements" may also be used under resilient floor coverings.

(b) Use 4d x 1-1/2-in. ring-shank nails, minimum 12-1/2 gage (0.099 in.) shank diameter, for underlayment panels 19/32 inch to 3/4 inch thick.

(c) For underlayment recommendations under ceramic tile, refer to Table 14.

(d) Fasten panels 3/8 inch from panel edges.

(e) Fasteners for 5-ply plywood underlayment panels and for panels greater than 1/2 inch thick may be spaced 6 inches on center at edges and 12 inches each way intermediate.

(f) See Table 5 for nail dimensions.

FIGURE 6

APA PLYWOOD UNDERLAYMENT

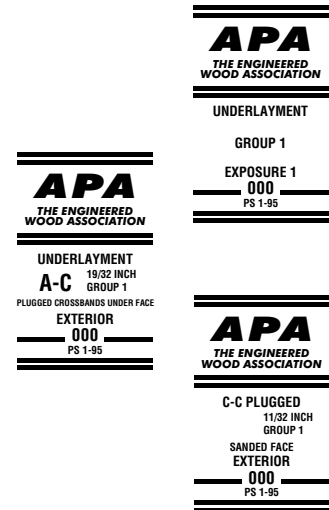
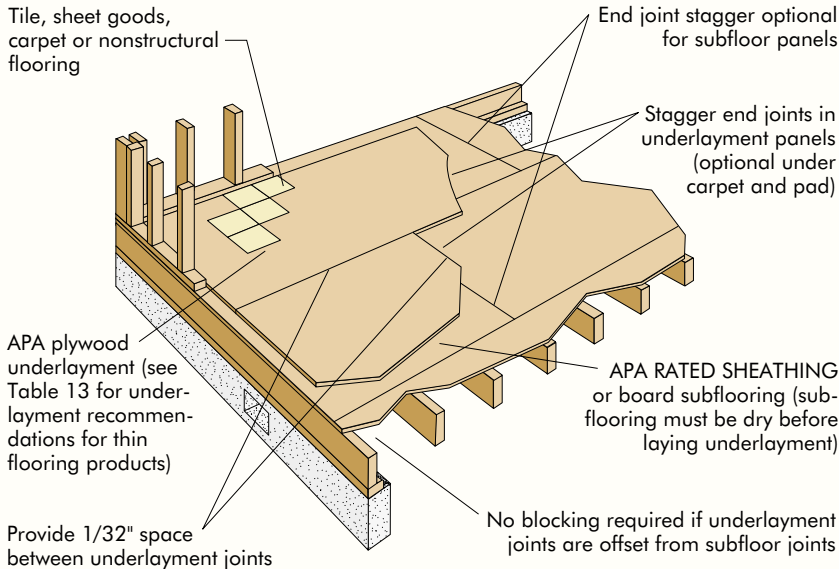

Hardwood Flooring Over APA Panel Subfloors

APA panel subfloor spans for 3/4-inch hardwood strip flooring are limited to maximum spacing of floor framing listed in [Tables 11](#) and [12](#). For improved stiffness, and to help eliminate floor squeaks when hardwood flooring is installed, spans reduced from the maximum are recommended by both the NOFMA: The Wood Flooring Manufacturers Association and the National Wood Floor Association (NWFA)*. Both NOFMA and NWFA also recommend the use of minimum 23/32-inch OSB and plywood as a subfloor material.

Because hardwood flooring is sensitive to moisture, make sure subflooring panels are dry before hardwood is installed. Use a moisture meter to measure the moisture content of the subfloor. Do not install hardwood unless subfloor moisture level is within a range consistent with the hardwood manufacturer's recommendations. If the home is built over a crawl space, make sure the crawl space is dry and well-drained. A 6-mil polyethylene vapor retarder should be installed on the ground in the crawl space.

Follow the recommendations of The Wood Flooring Manufacturers Association (NOFMA) or National Wood Flooring Association (NWFA) for the hardwood flooring product being used and its storage and handling, and for acclimatizing the hardwood prior to installation on the subflooring.

*NOFMA: The Wood Flooring Manufacturers Association, P.O. Box 3009, Memphis, Tennessee, 38173-0009; Phone (901) 526-5016.
National Wood Flooring Association, 111 Chesterfield Industrial Boulevard, Chesterfield, Missouri 63005; Phone (800) 422-4556.

Ceramic Tile Over APA Plywood Floors

Recommendations for several plywood floor systems suitable for application of ceramic tile are given in [Table 14](#), based on specifications of the Tile Council of America (TCA)*. For additional details and assemblies, see [Technical Topic: Ceramic Tile Over Wood Structural Panel Floors, TT-006](#), at www.apawood.org.

*Tile Council of America, Inc., 100 Clemson Research Blvd., Anderson, South Carolina 29625; Phone (864) 646-8453

TABLE 14

APA PLYWOOD SYSTEMS FOR CERAMIC TILE FLOORING (Based on ANSI Standard A108^(a) and specifications of the Tile Council of America)

Joist Spacing (in.)	Minimum Panel Thickness (in.)		Tile Installation
	Subfloor ^{(b)(c)}	Underlayment ^{(c)(d)}	
Residential			
16	19/32	15/32	Latex-portland-cement mortar
16	19/32	19/32	Organic adhesive
16	19/32	15/32 ^(e)	Epoxy mortar and grout
16	23/32	Cement mortar (1-1/4") ^(f)	Portland-cement paste while mortar bed is still workable or dry-set mortar or latex-portland-cement mortar on a cured bed.
19.2	23/32	(g)	Dry-set mortar or latex-portland-cement mortar. Polymer-modified grout.
24 ^(h)	23/32	3/8 ^(g)	Dry-set mortar or latex-portland-cement mortar. Polymer-modified tile grout.
24	23/32 (plywood or OSB)	19/32 ⁽ⁱ⁾	Latex-portland-cement mortar
Light Commercial			
16	19/32	19/32	Latex-portland-cement mortar
16	19/32	Cement mortar (1-1/4") ⁽ⁱ⁾	Portland-cement paste while mortar bed is still workable or dry-set mortar or latex-portland-cement mortar on a cured bed.
16	19/32	(k)	Latex-portland-cement mortar, dry-set mortar. Polymer-modified tile grout
16	19/32	(l)(m)	Dry-set mortar or latex-portland-cement mortar
16	19/32	19/32 ^(e)	Epoxy mortar and grout

(a) Recognizes plywood wood structural panel assemblies only.

(b) APA plywood (except as noted) RATED SHEATHING with Span Rating of 40/20 (19/32" panel) or 48/24 (23/32" panel) Exposure 1.

(c) See [Table 9](#), [11](#) or [12](#), as applicable, for panel fastening recommendations.

(d) APA Underlayment Exposure 1.

(e) Leave 1/4" space at panel ends and edges; trim panels as necessary to maintain end spacing and panel support on framing. Fill joints with epoxy mortar when it is spread for setting tile.

(f) 2.5 lb/yd² metal lath nailed or stapled over plywood. Use cleavage membrane over subfloor.

(g) Uncoupling system over plywood.

(h) Use 8"x8" tiles when supports are less than 2-1/4" wide.

(i) Use minimum 8"x8" tiles.

(j) Use cleavage membrane over subfloor. Reinforce mortar with wire mesh.

(k) Coated glass mat backer board fastened with galvanized nails or other corrosion-resistant fasteners.

(l) Attach cementitious backer units (CBU) over a supporting plane of "Dry-Set" or latex-portland-cement mortar with galvanized nails, screw-type nails or other corrosion-resistant fasteners. 7/16"-minimum-thick cementitious backer unit or minimum 1/4"-thick fiber-cement underlayment.

(m) Leave 1/8" space at panel ends and edges. Fill joints with "Dry-Set" or latex-portland-cement mortar.

APA Panel Stair Treads and Risers

A growing number of builders and manufacturers are using APA panels for treads and risers of both site-fabricated and prefabricated stairs in closed-riser stairways. Risers support the front and back of the tread, creating a very short effective span.

APA panel stair treads may be used interchangeably with boards when the system is to include closed risers. Maximum span between stringers is 42 inches (check local code requirements). Rounded nosing may be machined into the tread, but should be covered by a finish flooring material such as carpet and pad in order to prevent excessive wear or damage to veneers exposed by rounding. Risers may be any available APA panel grade at least 19/32-inch thick. Panel grade and thickness recommendations for the treads are given in Table 15.

Glue is recommended to improve stiffness of connections and to eliminate squeaks. Apply construction adhesive meeting APA Performance Specification AFG-01 or ASTM D3498 to all joints, with particular attention to the connection at the back riser. Regardless of where glue is used, nail all edges of treads as indicated in Figure 7. Detail A is the simplest system, but Detail B is preferred since it eliminates end-grain nailing at the back riser and may be used for all recommended panels.

TABLE 15

APA PANEL STAIR TREADS

Panel Grade ^(a)	Minimum Thickness (in.)	
	Nail-Glued	Nailed-Only
APA RATED		
STURD-I-FLOOR	19/32	23/32

(a) Other appropriate APA panel grades may be substituted for Sturd-I-Floor, providing minimum thickness complies with recommendations above.

FIGURE 7

APA PANEL STAIR TREADS AND RISERS

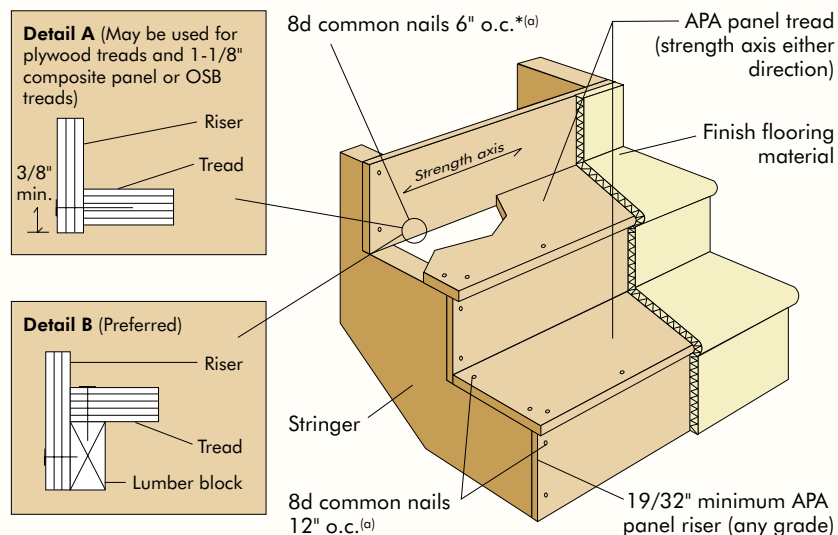

*Predrill tread end grain at mid-thickness with 3/32" bit. Maintain at least 3/8" edge distance in riser.

(a) See Table 5 for nail dimensions.

Heavy Duty Plywood Floors

Above-grade plywood floors may be designed to support forklift trucks in areas of heavy loading or to support relatively high loads imposed by warehouse shelving or stacked storage. Heavy-duty plywood floors also make excellent mezzanine decks and vibration-resistant surfaces for mounting computer equipment.

Tables 16 and 17 give plywood recommendations for uniform and concentrated (e.g., forklift traffic) loads. **These assume the use of plywood continuous over two or more spans with face grain across supports.** Structural edge support must be provided where high concentrated loads occur. Where no lift-truck use is expected, two-inch wood framing is adequate.

In addition to providing structural strength, a wearing surface should be provided to resist crushing wood cells and avoid abrasion whenever an industrial floor is subject to hard wheel or caster traffic. An expendable layer of plywood or a dense wear surface such as tempered hardboard should be used if wheels are small, hard or heavily loaded.

TABLE 16

PS 1 PLYWOOD RECOMMENDATIONS FOR UNIFORMLY LOADED HEAVY DUTY FLOORS^(a) (Deflection limited to 1/240 of span.) (Span Ratings apply to APA RATED SHEATHING and APA RATED STURD-I-FLOOR, respectively, marked PS 1.)

Uniform Live Load (psf)	Center-to-Center Support Spacing (inches) (Nominal 2-Inch-Wide Supports Unless Noted)					
	12 ^(b)	16 ^(b)	20 ^(b)	24 ^(b)	32	48 ^(c)
50	32/16, 16 oc	32/16, 16 oc	40/20, 20 oc	48/24, 24 oc	48 oc	48 oc
100	32/16, 16 oc	32/16, 16 oc	40/20, 20 oc	48/24, 24 oc	48 oc	1-1/2 ^(d)
125	32/16, 16 oc	32/16, 16 oc	40/20, 20 oc	48/24, 24 oc	48 oc	1-3/4 ^(d) , 2 ^(d)
150	32/16, 16 oc	32/16, 16 oc	40/20, 20 oc	48/24, 48 oc	48 oc	1-3/4 ^(e) , 2 ^(d)
200	32/16, 16 oc	40/20, 20 oc	48/24, 24 oc	48 oc	1-1/8 ^(e) , 1-3/8 ^(d)	2 ^(e) , 2-1/2 ^(d)
250	32/16, 16 oc	40/20, 24 oc	48/24, 48 oc	48 oc	1-3/8 ^(e) , 1-1/2 ^(d)	2-1/4 ^(e)
300	32/16, 16 oc	48/24, 24 oc	48 oc	48 oc	1-1/2 ^(e) , 1-5/8 ^(d)	2-1/4 ^(e)
350	40/20, 20 oc	48/24, 48 oc	48 oc	1-1/8 ^(e) , 1-3/8 ^(d)	1-1/2 ^(e) , 2 ^(d)	
400	40/20, 20 oc	48 oc	48 oc	1-1/4 ^(e) , 1-3/8 ^(d)	1-5/8 ^(e) , 2 ^(d)	
450	40/20, 24 oc	48 oc	48 oc	1-3/8 ^(e) , 1-1/2 ^(d)	2 ^(e) , 2-1/4 ^(d)	
500	48/24, 24 oc	48 oc	48 oc	1-1/2 ^(d)	2 ^(e) , 2-1/4 ^(d)	

- (a) Use plywood with T&G edges, or provide structural blocking at panel edges, or install a separate underlayment.
- (b) A-C Group 1 sanded plywood panels may be substituted for span-rated Sturd-I-Floor panels (1/2-inch for 16 oc; 5/8-inch for 20 oc; 3/4-inch for 24 oc).
- (c) Nominal 4-inch-wide supports.
- (d) Group 1 face and back, any species inner plies, sanded or unsanded, single layer.
- (e) All-Group 1 or Structural I plywood, sanded or unsanded, single layer.

TABLE 17

PS 1 PLYWOOD RECOMMENDATIONS FOR FLOORS CARRYING FORK-TRUCK TRAFFIC^{(a)(b)(c)} (Plywood grade is all-Group 1 or Structural I A-C or C-C Plugged, except where 2-4-1 [STURD-I-FLOOR 48 oc marked PS 1] is noted.)

Tire Tread Print Width (in.)	Load per Wheel (lbs.)	Center-to-Center Support Spacing (in.) (Minimum 3-Inch-Wide Supports)			
		12	16	20	24
3	500	2-4-1	2-4-1	2-4-1	2-4-1
	1000	1-1/4"	1-1/4"	1-1/4"	1-1/4"
	1500	1-1/2"	1-3/4"	1-3/4"	1-3/4"
	2000	2"	2"	2-1/4"	2-1/4"
5	1000	2-4-1	2-4-1	1-1/8"	1-1/8"
	1500	1-1/8"	1-1/8"	1-1/4"	1-1/4"
	2000	1-1/4"	1-1/2"	1-1/2"	1-3/4"
	2500	1-1/2"	2"	2"	2"
	3000	1-3/4"	2"	2-1/4"	2-1/4"
7	2000	1-1/8"	1-1/8"	1-1/4"	1-1/4"
	3000	1-1/4"	1-1/2"	1-1/2"	1-3/4"
	4000	1-3/4"	1-3/4"	1-3/4"	2"
	5000	2"	2"	2-1/4"	2-1/2"
	6000	2-1/4"	2-1/2"	2-3/4"	3"
9	3000	1-1/4"	1-1/4"	1-1/4"	1-1/4"
	4000	1-1/2"	1-1/2"	1-3/4"	1-3/4"
	5000	1-3/4"	1-3/4"	2"	2"
	6000	2"	2"	2-1/4"	2-1/4"
	7000	2-1/4"	2-1/4"	2-3/4"	2-3/4"

- (a) Structural blocking (3x4 or 2x6 min.) required at all panel edges. Support blocking with framing anchors of adequate capacity or similar devices.
- (b) Provide a wearing surface such as Plyron, polyethylene or a separate layer of plywood, hardboard or other hard surface when loads are due to casters, or small, hard wheels. A wearing surface should also be considered for areas where fork-truck traffic is stopping, starting or turning in a tight radius.
- (c) Use ring- or screw-shank nails with length sufficient to penetrate framing 1-1/2" or panel thickness, whichever is greater. Space nails maximum 4" o.c. at panel edges and 8" o.c. at intermediate supports.



WALL CONSTRUCTION

APA Sturd-I-Wall®

The APA Sturd-I-Wall system consists of APA RATED SIDING (panel or lap) applied direct to studs or over nonstructural fiberboard, gypsum or rigid foam insulation sheathing. Nonstructural sheathing is defined as sheathing not recognized by building codes as meeting both bending and racking strength requirements.

A single layer of panel siding, since it is strong and rack resistant, eliminates the cost of installing separate structural sheathing or diagonal wall bracing. Panel sidings are normally installed vertically, but may also be placed horizontally (long dimension across supports) if horizontal joints are blocked. Maximum stud spacings for both applications are given in [Table 18](#).

TABLE 18

APA STURD-I-WALL CONSTRUCTION
(Recommendations apply to APA Rated Siding direct to studs and over nonstructural sheathing.)

Siding Description ^(a)	Nominal Thickness (in.) or Span Rating	Max. Stud Spacing (in.)		Nail Size (Use nonstaining box, siding or casing nails) ^{(b)(c)(f)}	Max. Nail Spacing ^(e) (in.)	
		Strength Axis Vertical	Strength Axis Horizontal		Panel Edges ^(h)	Intermediate Supports
Panel Siding	11/32 & 3/8	16	24	6d for siding 1/2" thick or less; 8d for thicker siding	6 ^(d)	12 ^(f)
	15/32 & thicker	24	24			
	16 oc (including T1-11)	16	16 ^(g)			
	24 oc	24	24			
Lap Siding	16 oc	—	16	6d for siding 1/2" thick or less; 8d for thicker siding	16 along bottom edge	—
	24 oc	—	24		24 along bottom edge	—

(a) For veneered APA Rated Siding, including APA 303 Siding, recommendations apply to all species groups.

(b) If panel siding is applied over foam insulation sheathing, use next regular nail size. If lap siding is installed over rigid foam insulation sheathing up to 1 inch thick, use 10d (3") nails for 3/8" or 7/16" siding, 12d (3-1/4") nails for 15/32" or 1/2" siding, and 16d (3-1/2") nails for 19/32" or thicker siding. Use nonstaining box nails for siding installed over foam insulation sheathing.

(c) Hot-dip or hot-tumbled galvanized steel nails are recommended for most siding applications. For best performance, stainless steel nails or aluminum nails should be considered. APA tests also show that electrically or mechanically galvanized steel nails appear satisfactory when plating meets or exceeds thickness requirements of ASTM A641 Class 2 coatings, and is further protected by yellow chromate coating.

Note: Galvanized fasteners may react under wet conditions with the natural extractives of some wood species and may cause

staining if left unfinished. Such staining can be minimized if the siding is finished in accordance with APA recommendations, or if the roof overhang protects the siding from direct exposure to moisture and weathering.

(d) For braced wall section with 11/32" or 3/8" panel siding applied horizontally over studs 24" o.c., space nails 3" o.c. along panel edges.

(e) Recommendations of siding manufacturer may vary.

(f) Where basic wind speed exceeds 90 mph (3-second gust), nails attaching siding to intermediate studs within 10% of the width of the narrow side from wall corners shall be spaced 6" o.c.

(g) Stud spacing may be 24" o.c. for veneer-faced siding panels.

(h) Supported panel joints shall occur approximately along the centerline of framing with a minimum bearing of 1/2". Fasteners shall be located 3/8 inch from panel edges.

(i) See [Table 5, page 13](#), for nail dimensions.

When installing panel or lap siding over rigid foam insulation sheathing, drive the nails flush with the siding surface, but avoid over-driving, which can result in dimpling of the siding due to the compressible nature of foam sheathing.

Sidings are occasionally treated with water repellents or wood preservatives to improve finishing characteristics or moisture resistance for certain applications. If the siding has been treated, be sure the surface treatment is dry to avoid solvent or chemical reaction with the foam sheathing.

When rigid foam insulation sheathing is used, building codes also generally require installation of 1/2-inch gypsum wallboard, or other materials of the required thermal barrier rating, on the inside surface of the wall for fire protection.

See [Figures 8 through 12](#) for panel and lap siding installation recommendations for the Sturd-I-Wall system or for siding installed over nailable sheathing. See APA's [Build A Better Home: Walls, Form A530](#), for additional recommended details to avoid moisture penetration in walls.

All panel siding edges in Sturd-I-Wall construction should be backed with framing or blocking. Use nonstaining, noncorrosive nails as described in [Tables 18 and 19](#) to prevent staining the siding.

Where siding is to be applied at an angle, install only over nailable sheathing.

Note: Gluing of siding to framing is not recommended due to the increased potential for panel buckling.

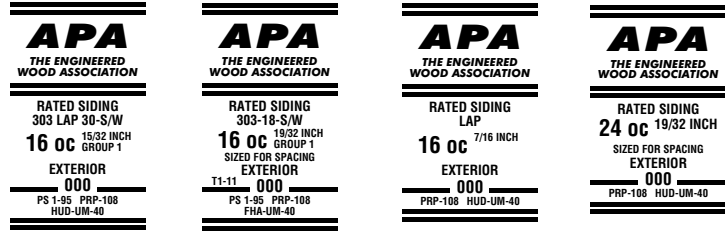

FIGURE 8

APA STURD-I-WALL (Vertical Panel Installation)

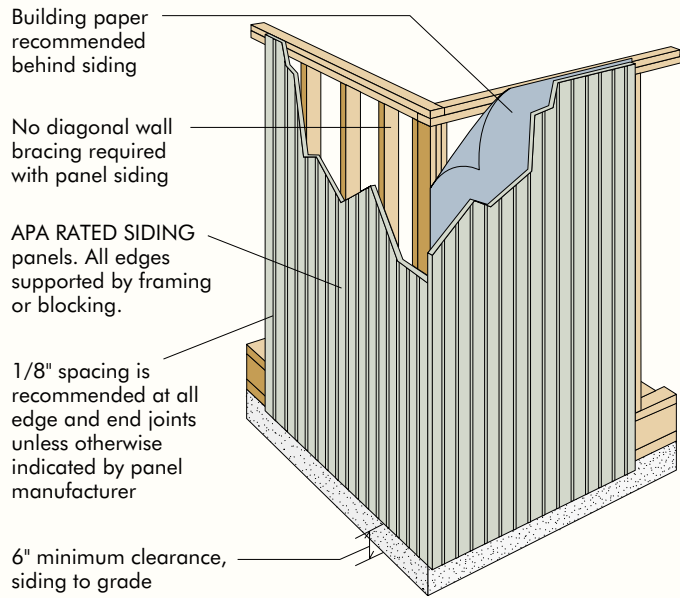
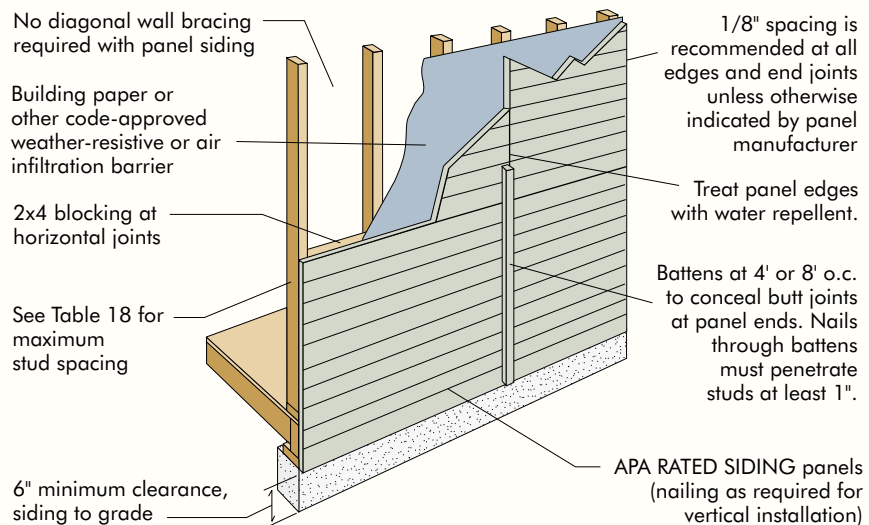

FIGURE 9

APA STURD-I-WALL (Horizontal Panel Siding Installation)



APA Panel and Lap Siding Over Nailable Sheathing

The recommendations in [Table 19](#) for panel and lap siding apply to siding installed over nailable sheathing. Unless otherwise indicated in the local building code, nailable sheathing includes:

1. Nominal 1-inch boards with studs 16 or 24 inches o.c.
2. APA RATED SHEATHING panels with roof Span Rating of 24 inches or greater installed with strength axis either parallel or perpendicular to studs 16 or 24 inches o.c. (except 3-ply plywood panels must be applied with strength axis across studs when studs are spaced 24 inches o.c.).
3. APA RATED SHEATHING panels with roof Span Rating less than 24 inches installed with strength axis either parallel or perpendicular to studs 16 inches o.c. (except plywood panels 3/8 inch thick or less must be applied with strength axis across studs).

Lap siding joints, if staggered, and panel siding joints may occur away from studs with nailable sheathing.

Note: In addition to panel edge spacing and the use of straight studs, nailing sequence can also be a factor in maintaining a uniformly flat appearance of the finished wall. Installation procedure: First, position the panel, maintaining recommended edge spacing, and lightly tack at each corner. Install the first row of nails at the edge next to the preceding panel from top to bottom. Remove remaining tacking nails. Then nail the row at the first intermediate stud. Continue by nailing at the second intermediate stud, and finally, at the edge opposite the preceding panel. Complete the installation by fastening to the top and bottom plates.

TABLE 19

APA RATED SIDING OVER NAILABLE SHEATHING (For siding over types of nonstructural sheathing, see Sturd-I-Wall recommendations.)

Siding Description ^(a)	Nominal Thickness (in.) or Span Rating	Max. Spacing of Vertical Rows of Nails (in.)		Nail Size (Use nonstaining box, siding or casing nails) ^{(b)(c)(e)}	Max. Nail Spacing ^(c) (in.)	
		Strength Axis Vertical	Strength Axis Horizontal		Panel Edges ^(d)	Intermediate Supports
Panel Siding	11/32 & 3/8	16	24			
	15/32 & thicker	24	24	6d for siding 1/2" thick or less; 8d for thicker siding	6	12
	16 oc (including T1-11)	16	24			
	24 oc	24	24			
Lap Siding	11/32 & thicker	—	—			
	11/32 & thicker	—	—	6d for siding 1/2" thick or less; 8d for thicker siding	8 along bottom edge	—
	or 16 oc or 24 oc	—	—			

(a) For veneered APA Rated Siding, including APA 303 Siding, recommendations apply to all species groups.

(b) Hot-dip or hot-tumbled galvanized steel nails are recommended for most siding applications. For best performance, stainless steel nails or aluminum nails should be considered. APA tests also show that electrically or mechanically galvanized steel nails appear satisfactory when plating meets or exceeds thickness requirements of ASTM A641 Class 2 coatings, and is further protected by yellow chromate coating.

Note: Galvanized fasteners may react under wet conditions with the natural extractives of some wood species and may cause

staining if left unfinished. Such staining can be minimized if the siding is finished in accordance with APA recommendations, or if the roof overhang protects the siding from direct exposure to moisture and weathering.

(c) Recommendations of siding manufacturer may vary.

(d) Supported panel joints shall occur approximately along the centerline of framing with a minimum bearing of 1/2". Fasten panels 3/8 inch from panel edges.

(e) See [Table 5, page 13](#), for nail dimensions.

FIGURE 10

APA STURD-I-WALL (Horizontal Lap Siding Installation)^(a)

APA RATED SIDING (lap siding), maximum width 12".
Minimum headlap 1".

Leave 1/8" spacing and caulk vertical joints unless otherwise recommended by siding manufacturer

1-1/2"-wide starter strip, thickness to match lap siding

Building paper or other code-approved weather-resistant or air infiltration barrier required

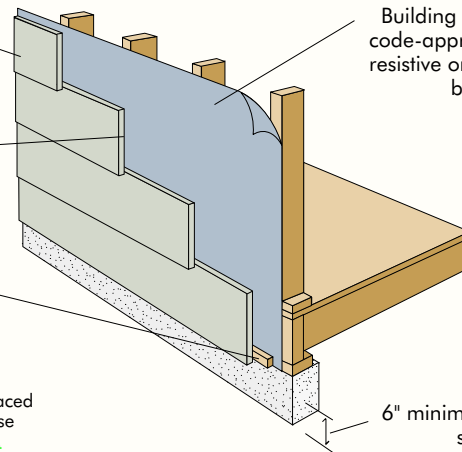

(a) Diagonal bracing methods permitted by model building codes for braced wall segments must be provided. For engineered shear wall segments, use APA Rated Sheathing for wall sheathing under lap siding (see Figure 12).

6" minimum clearance, siding to grade

FIGURE 11

APA RATED SIDING (PANEL SIDING) OVER NAILABLE SHEATHING

1/8" spacing is recommended at all edge and end joints unless otherwise indicated by panel manufacturer

Building paper or other code-approved weather-resistant or air infiltration barrier

Panel siding meets code requirement for wall bracing

APA RATED SIDING panels applied over sheathing

6" minimum clearance, siding to grade

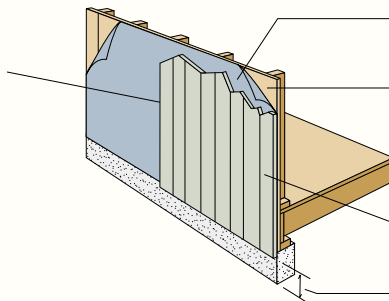

FIGURE 12

APA RATED SIDING (LAP SIDING) OVER NAILABLE SHEATHING

Siding joints, if staggered may occur away from studs with nailable sheathing

APA RATED SIDING (lap siding), maximum width 12".
Minimum headlap 1".

Leave 1/8" spacing and caulk vertical joints, unless otherwise recommended by siding manufacturer

1-1/2"-wide starter strip, thickness to match lap siding

APA RATED SHEATHING fulfills code requirement for wall bracing

Building paper or other code-approved weather-resistant or air infiltration barrier

6" minimum clearance, siding to grade

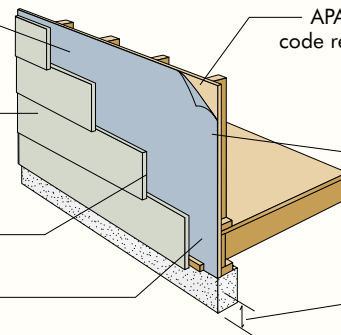

APA Panel Wall Sheathing

APA RATED SHEATHING easily meets building code wall sheathing requirements for bending and racking strength. Even when fiberboard or other nonstructural sheathing is used, APA RATED SHEATHING corner panels (Figure 14) of the same thickness meet code wall-bracing requirements. Installation recommendations are given in Figure 13.

Recommended wall sheathing spans with brick veneer or masonry are the same as those for panel sheathing (see Table 20). See Figure 15 for installation recommendations.

Panel recommendations for preframed wall sections are the same as for built-in-place walls.

Note: To minimize the potential for panel buckling, gluing of wall sheathing to framing is not recommended, except when recommended by the adhesive manufacturer for wall sheathing that already has been permanently protected by siding.

TABLE 20

APA PANEL WALL SHEATHING^(a)
(APA RATED SHEATHING panels continuous over two or more spans.)

Panel Span Rating	Maximum Stud Spacing (in.)	Nail Size ^{(b)(c)(f)}	Maximum Nail Spacing (in.) ^(e)	
			Supported Panel Edges ^(d)	Intermediate Supports
12/0, 16/0, 20/0 or Wall-16 oc	16	6d for panels 1/2" thick or less; 8d for thicker panels	6	12
24/0, 24/16, 32/16 or Wall-24 oc	24			

- (a) See requirements for nailable panel sheathing when exterior covering is to be nailed to sheathing.
- (b) Common, smooth, annular, spiral-thread, or galvanized box.
- (c) Other code-approved fasteners may be used.
- (d) Fasteners shall be located 3/8 inch from panel edges.
- (e) Increased nail schedules may be required where wall is engineered as a shear wall.
- (f) See Table 5, page 13, for nail dimensions.

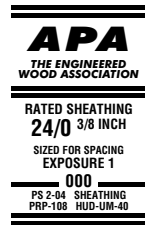

FIGURE 13

APA PANEL WALL SHEATHING

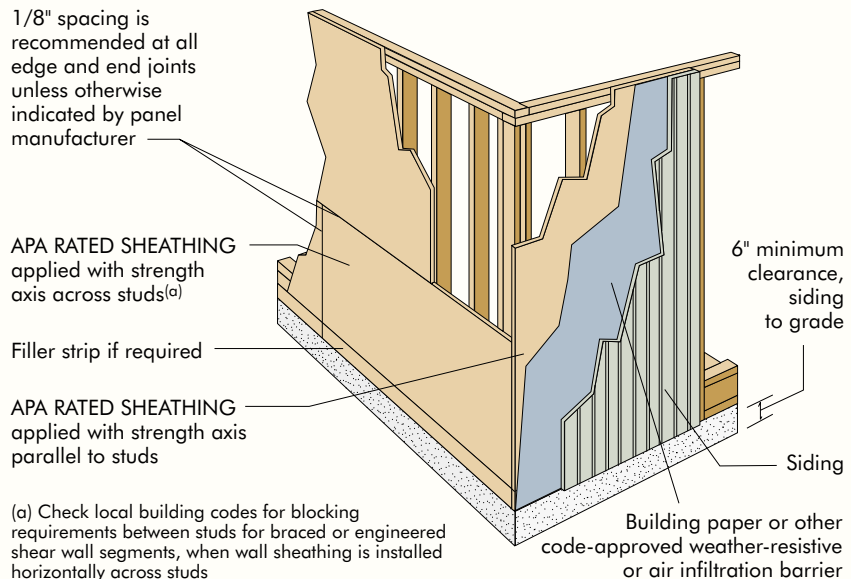
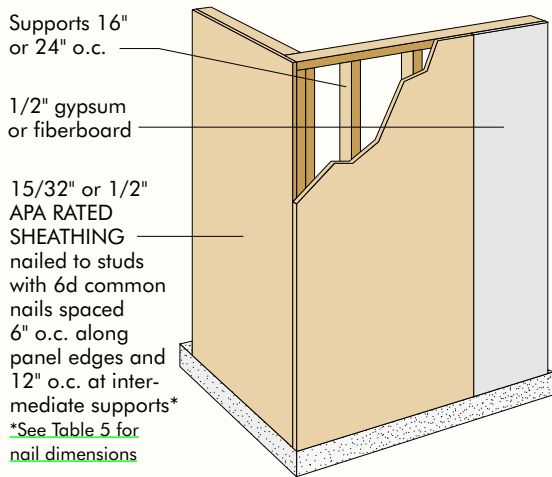

FIGURE 14

APA PANEL CORNER BRACING



For additional information on wall bracing and the narrow wall bracing method, see [Narrow Walls That Work, Form D420](#).

FIGURE 15

BRICK VENEER OVER APA PANEL SHEATHING

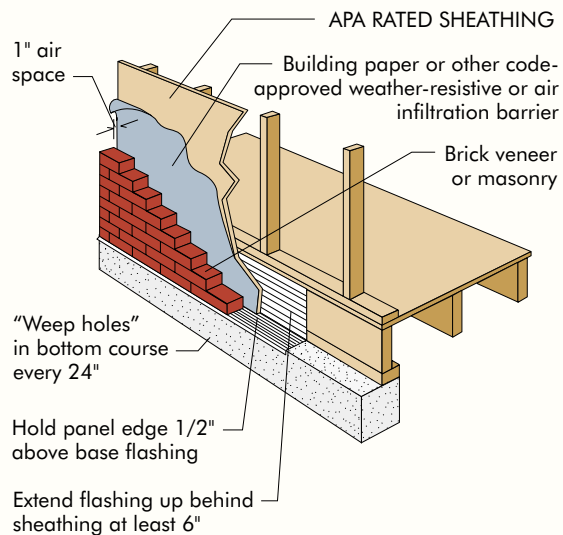

APA Sheathing Under Stucco

Greater stiffness is recommended for wall sheathing when stucco is to be applied. To increase stiffness, apply the long panel dimension or strength axis across studs. Blocking or a plywood cleat is recommended at horizontal joints. Blocking is required for shear wall applications. For panel recommendations applied horizontally or vertically, see [Table 21](#).

Siding Joint Details

The siding joint details in [Figure 17](#) are based on the use of APA trademarked siding. Nailing of wood structural panel siding along both edges of shiplap joints (“double nailing”), as shown, is required for shear-walls or those wall segments that must meet bracing requirements. Double nailing is recommended for all other applications as well to provide maximum wall strength and moisture protection.

Where caulks or joint sealants are indicated, consider the various types available such as urethane, plasticized acrylic latex, butyl and polysulfide. Check with the manufacturer of the caulk or sealant to determine suitability for the intended application and compatibility with coatings and other building materials such as vinyl and aluminum.

In some cases a foam rod or other type filler material may be used behind the sealants as recommended by the manufacturer. For best results in other cases, apply caulking to framing at panel edges before installing the siding panel; or apply a bead of caulk along the panel edge before installing the next panel. A 1/8-inch space is recommended at all edge and end joints unless otherwise indicated by panel manufacturer. If caulk is to be used, also check with caulk manufacturer for

TABLE 21

RECOMMENDED THICKNESS AND SPAN RATING FOR APA PANEL WALL SHEATHING FOR STUCCO EXTERIOR FINISH

Stud Spacing (in.)	Panel Orientation ^(a)	APA Rated Sheathing ^(c)	
		Minimum Thickness (in.)	Minimum Span Rating
16	Horizontal ^(b)	3/8	24/0
	Vertical	7/16 ^(e) 15/32 ^(d) , 1/2 ^(d)	24/16 32/16
24	Horizontal ^(b)	7/16	24/16
	Vertical	19/32 ^(d) , 5/8 ^(d)	40/20

(a) Strength axis (typically the long panel dimension) perpendicular to studs for horizontal application; or parallel to studs for vertical application.

(b) Blocking recommended between studs along horizontal panel joints.

(c) Recommendations apply to all-veneer plywood or oriented strand board (OSB) except as noted.

(d) OSB or 5-ply/5-layer plywood.

(e) Structural I Rated Sheathing (OSB).

recommended edge spacing. Nails through battens or other wood trim must penetrate at least one inch into studs. Nail panel siding 6 inches o.c. along edges and 12 inches o.c. at intermediate supports. To prevent staining of siding, use hot-dip galvanized, aluminum, or other nonstaining nails as described in [Tables 18](#) and [19](#).

Siding is often fully exposed to weather and thus has increased susceptibility to elevated moisture conditions. Although siding will periodically experience moisture contents above the threshold value needed to support decay, wood-based siding products have a good history of performance because they dry below this threshold value before decay can initiate. If trim is installed around siding, be sure that it doesn't trap moisture or reduce the drying ability of the wood. Trim that is applied incorrectly can lead to long-term moisture accumulation that causes decay.

Apply flashing or other means of protection over end grain of siding to minimize water absorption.

APA Rated Siding Patterns and Grades

APA RATED SIDING, including 303 plywood siding, is available in a wide variety of surface textures and patterns. For descriptions of siding surface patterns and thicknesses, refer to *APA Product Guide: APA Performance Rated Sidings*, Form E300. Actual dimensions of groove spacing, width and depth may vary with the manufacturer. Where the characteristics of a particular wood species are desired, specify by grade and species preference.

In order to help specifiers select the most appropriate siding appearance for any particular job, APA 303 plywood sidings are also identified by a face grading system. There are four basic siding classifications within the system – Special Series 303, 303-6, 303-18 and 303-30. Each class, as shown in [Table 22](#), is further divided into grades according to categories of repair and appearance characteristics.

**FIGURE 16
STUCCO OVER APA PANEL SHEATHING**

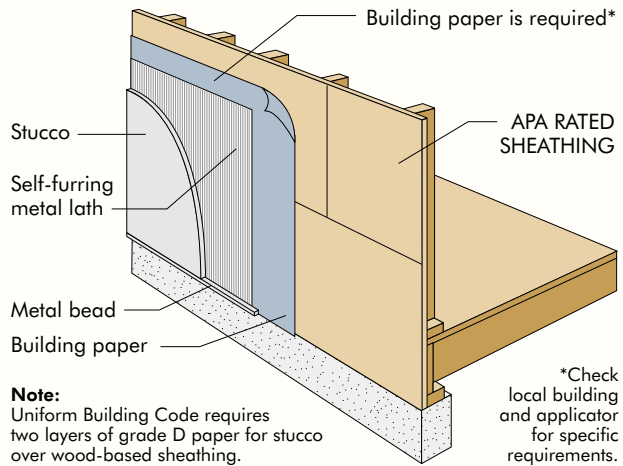

Note:
Uniform Building Code requires two layers of grade D paper for stucco over wood-based sheathing.

TABLE 22

APA 303 SIDING FACE GRADES^(a)

303 Series Plywood Siding Grades	Type of Patch	
	Wood	Synthetic
303-OC	Not permitted	Not permitted
303-OL	Not applicable for overlays	
303-NR	Not permitted	Not permitted
303-SR	Not permitted	Permitted as natural-defect shape
303-6-W	Limit 6	Not permitted
303-6-S	Not permitted	Limit 6
303-6-S/W	Limit 6 – any combination	
303-18-W	Limit 18	Not permitted
303-18-S	Not permitted	Limit 18
303-18-S/W	Limit 18 – any combination	
303-30-W	Limit 30	Not permitted
303-30-S	Not permitted	Limit 30
303-30-S/W	Limit 30 – any combination	

(a) All panels except 303-NR allow restricted minor repairs such as shims. These and such other face appearance characteristics as knots, knotholes, splits, etc., are limited by both size and number in accordance with panel grades, 303-OC being most restrictive and 303-30 being least. Multiple repairs are permitted only on 303-18 and 303-30 panels. Patch size is restricted on all panel grades.

FIGURE 17

TYPICAL PANEL SIDING JOINT DETAILS

(Note: Water-resistant barrier [building paper or house wrap] is recommended behind siding; also check local building code.)

VERTICAL WALL JOINTS

Butt

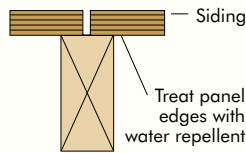

Shiplap

Reverse Board and Batten

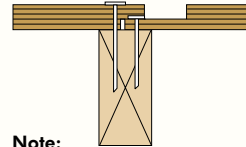

T1-11 & Channel Groove

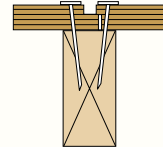

Note:

Nailing of both panel edges along shiplap joint is recommended. The "double nailing" is required when wall segment must meet wall bracing or engineered shear wall requirements.

Vertical Batten

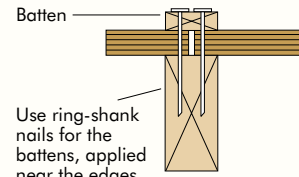

Use ring-shank nails for the battens, applied near the edges in two staggered rows

VERTICAL INSIDE & OUTSIDE CORNER JOINTS

Butt & Caulk

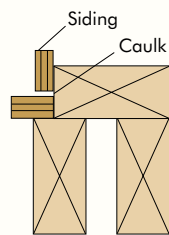

Corner Board Lap Joints

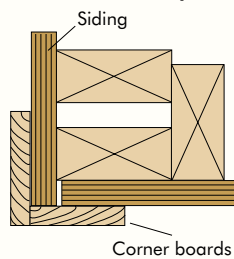

Lap Siding (APA Sturd-I-Wall)

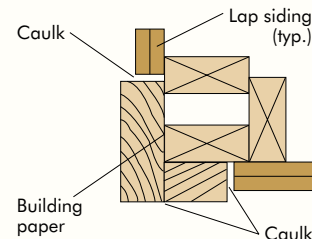
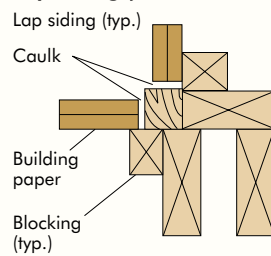

HORIZONTAL WALL JOINTS

Butt & Flash

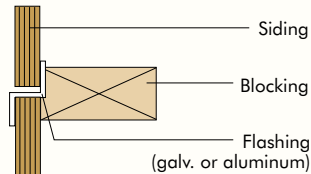

Lap

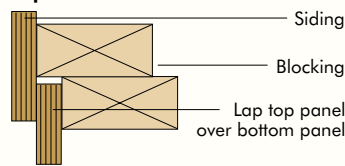

Shiplap

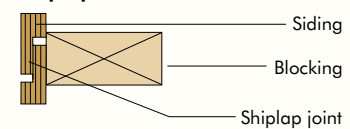

HORIZONTAL BELTLINE JOINTS

(For multistory buildings, when conventional lumber floor joists and rim boards are used, make provisions at horizontal joints for shrinkage of framing, especially when applying siding direct to studs.)

Jog Exterior Stud Line

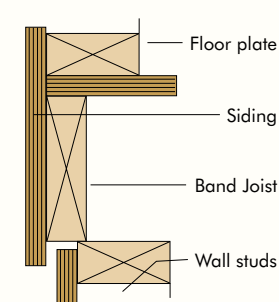

Band Board Over Panel Filler

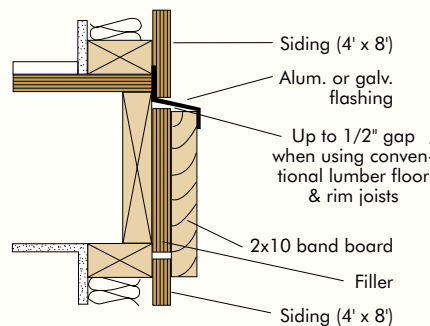

Band Board In Relief

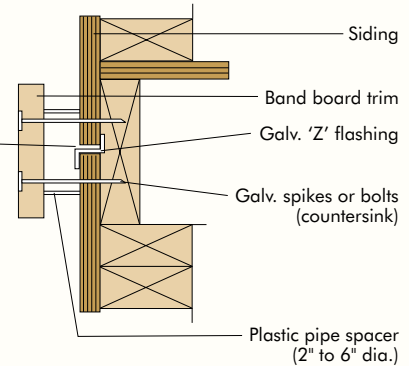

WINDOW DETAILS

(For window details, see *Build A Better Home: Walls, Form A530.*)

Finishing Plywood for Exterior Exposure

Care and Preparation

Plywood should be stored and handled with care to avoid damaging before finishing. Storage in a cool, dry place out of sunlight and weather is best. If left outdoors, straps on bundles should be loosened or cut and the plywood covered. Allow good air circulation to prevent moisture condensation and possible mold growth.

Edge Sealing

Moisture enters the end grain of plywood or other wood-based products faster than through the surface. Consequently, edges and ends of APA RATED SIDING panels or lap siding should be sealed. Although edge sealers are not necessarily moisture-proof or permanently durable, they help to minimize sudden changes in moisture content in the siding, due to weather.

APA RATED SIDING may be edge sealed at the factory. If the siding is not factory-sealed, it can be sealed quickly at the job site while the panels or lap siding pieces are still in a stack. Edges or ends cut during construction should be resealed.

Siding to be finished with a semitransparent or solid-color stain can be edge sealed with a liberal application of a paintable, water-repellent sealer. If the siding is to be painted, use the same paint primer that will be used on the surface. Horizontal edges, particularly lower drip edges of siding, should be given special care because of their greater wetting exposure.

Finishing

APA RATED SIDING may be finished with a variety of products such as semitransparent stains, solid-color stains or paint systems. The recommended finishes depend on the type of siding product, and whether it has an overlaid surface.

Oil-based, semitransparent stains may be used on certain veneer-faced siding products as detailed in [Table 23](#). Solid-color stains may be used on most APA RATED SIDING products and usually provide better protection. In general, however, best overall performance on APA RATED SIDING products can be achieved with an all-acrylic latex paint system.

For overlaid siding, any top-quality exterior house paint system formulated for wood performs satisfactorily. Solid-color stains may also be used on overlaid sidings, although some manufacturers recommend only acrylic latex formulations. For specific recommendations on finishing OSB siding products, consult the siding manufacturer.

Table 23 provides a summary of finishing recommendations for APA 303 Siding face grades. For complete information, write for [APA Product Guide: Performance Rated Sidings, Form E300](#).

Semitransparent Stains (oil-based only)

Oil-based semitransparent stains emphasize grain patterns, texture and natural characteristics in the wood. They may be used on plywood face grades 303-OC, 303-NR and 303-6-W. It is the only finish recommended for use over brushed plywood. Other 303 face grades should not be finished with semitransparent stains unless specifically recommended by the panel manufacturer.

Solid-Color Stains (oil or all-acrylic latex)

An opaque or solid-color stain obscures color differences in the wood and between repairs and surrounding wood. This is often a satisfactory finishing system, therefore, where semitransparent stains are unsuitable. Wood grain is also muted with solid-color stains but wood surface textures usually remain evident. When in question, the finish should be applied to a representative sample in order to demonstrate the finished appearance.

Solid-color stains are particularly recommended for grades 303-6-S and 303-6-S/W, as well as 303-18 and 303-30 with any type of patch.

Paints (all-acrylic latex)

Top-quality acrylic latex house paint systems are recommended for all APA Rated Sidings, except brushed plywood. If house paint is used on plywood siding, an all-acrylic latex paint system consisting of at least one stain-blocking prime coat and an all-acrylic latex topcoat is recommended. For extractive staining woods, some house paint systems utilize an oil-alkyd primer. Others use up to two coats of a stain-blocking acrylic latex primer. These latter systems help to reduce face-checking and generally offer superior performance. A paint finish tends to mask the textured plywood surface more than either semitransparent or solid-color stains. On the other hand, a top-quality acrylic latex paint system provides the most durable finish.

Grade 303-OL may be finished with any top-quality exterior paint system – primer and companion topcoat – formulated for wood.

Field Application of Finish

Proper surface preparation is important for good performance of finishes on any surface. Remove dirt and loose wood fibers with a stiff nonmetallic bristle brush. Mildew may be removed with a solution of 1/4 part household bleach to 3/4 part warm water. Be sure to rinse thoroughly after application of bleach.

Finishes should be applied as soon as possible after installation of the siding. Weathering of unprotected wood can cause surface damage in as little as two to four weeks. Apply finishes during favorable weather conditions. As a rule of thumb, finishes should not be applied when the outside air temperature is expected to drop below 50° F (10° C) within 24 hours for latex finishes, or 40° F (5° C) for oil-based finishes. However, recommendations of individual manufacturers may vary and should always be followed. Wood surfaces should be clean and dry, although extremely dry surfaces should be dampened slightly when applying latex finishes.

Use only top-quality finishes and application equipment. Finishes should be applied according to the spread rates recommended by the manufacturer. Textured surfaces may require up to twice as much finish as smooth surfaces. The first coat should be applied by brush. If spray equipment is used to apply the finish, then the finish should be either back-brushed or back-rolled while it is still wet. Subsequent coats of finish may be applied by any conventional means.

Interior Paneling

APA Rated Siding panels lend themselves to a number of decorative surface treatments for attractive interior paneling and accent walls. (See [Figures 18 and 19](#).) Such treatments include saw-textured, brushed, embossed and grooved. Let APA panels acclimatize to room temperature and humidity conditions for several days prior to attachment to the wall. This can be accomplished by placing the panels on edge with space between each panel to allow air to circulate freely over both sides. Preservative treatment of furring or studs is recommended when they are attached to masonry or concrete exterior

TABLE 23

APA 303 SIDING FINISHING RECOMMENDATIONS

303 Series Plywood Siding Grades	STAINS		PAINTS
	Semitransparent (oil)	Solid Color (oil or latex) ^(a)	Minimum 1 primer plus 1 topcoat (acrylic latex)
303-OC	(b)	(b)	(b)
303-OL	Not Recommended	(d)	(b)
303-NR	(b)	(e)	(e)
303-SR	(c)	(e)	(e)
303-6-W	(b)	(b)	(b)
303-6-S	(c)	(b)	(b)
303-6-S/W	(c)	(b)	(b)
303-18-W	(c)	(b)	(b)
303-18-S	(c)	(b)	(b)
303-18-S/W	(c)	(b)	(b)
303-30-W	(c)	(b)	(b)
303-30-S	(c)	(b)	(b)
303-30-S/W	(c)	(b)	(b)

(a) Except for overlaid panels, use a stain-resistant primer with light-colored latex stains, since the wood extractives may cause a discoloration of the finish.

(b) Recommended with provisions given in text.

(c) Should not be finished with semitransparent stain unless specifically recommended by the panel manufacturer.

(d) Some panel manufacturers recommend only acrylic latex formulations. Consult the manufacturer's recommendations.

(e) Only acrylic latex formulations are recommended when solid-color stains or paint systems are applied over open voids.

walls and to any uncured concrete wall. Also, in these instances, install a 4-mil polyethylene vapor retarder between the paneling and the furring or studs and insulate exterior walls. Support and nail spacing recommendations are given in [Table 24](#). Recommendations apply to all species groups.

TABLE 24

INTERIOR PANELING

Panel Thickness (in.)	Maximum Support Spacing (in.)	Nail Size (Use casing or finishing nails) ^(c)	Maximum Nail Spacing (in.)	
			Panel Edges	Intermediate Supports
1/4	16 ^(a)	4d	6	12
5/16	16 ^(b)	6d	6	12
11/32 - 1/2	24	6d	6	12
19/32 - 3/4	24	8d	6	12
Texture 1-11	24	8d	6	12

(a) Can be 20 inches if strength axis of paneling is across supports.

(c) See [Table 5](#), page 13, for nail dimensions.

(b) Can be 24 inches if strength axis of paneling is across supports.

FIGURE 18

PANELING NEW INTERIOR WALLS

Leave 1/32" spacing at panel edges

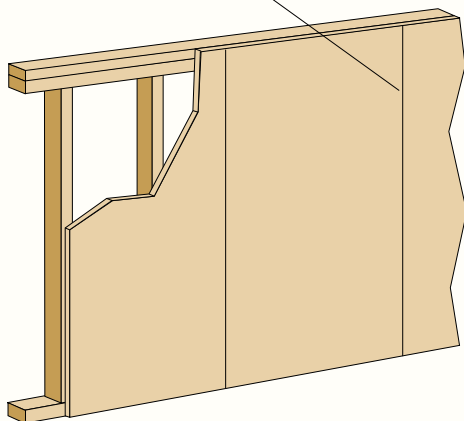

Note:
If applied horizontally, block all unsupported edges.

FIGURE 19

PANELING EXISTING INTERIOR WALLS

Leave 1/32" spacing at panel edges

Install 1x2 furring strips horizontal and/or vertical with nails into studs, expansion bolts, concrete nails, powder-actuated fasteners, or adhesive as necessary

Block all unsupported edges

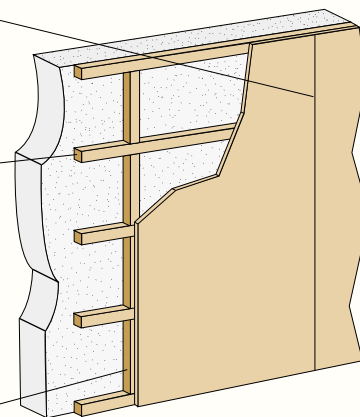

Panel Backing

Wood structural panels are excellent backing for wall coverings such as rare hardwoods, vinyl surfaces and decorative fabrics. Panels less than 15/32 inch thick should be applied with strength axis perpendicular to studs and with 2x4 blocking at horizontal edges. Thicker plywood may be applied with strength axis parallel to studs. Plywood panels should have C-Plugged or better faces. Use 6d nails spaced 6 inches on center at panel edges and 12 inches on center at intermediate supports. A 1/16-inch space should be left between panels. Where moisture may be present, use nonstaining nails and either Exposure 1 or Exterior type panels. A 1/4-inch clearance is recommended at the bottom edge of the panels.

APA Panel Shear Walls

While all of the wall systems presented here will provide sufficient strength under normal conditions in residential and light-frame construction, engineered shear walls may be desirable or required in areas of the country with frequent seismic activity or high wind loads. Shear walls, of course, are also integral to commercial and industrial construction.

Either APA RATED SHEATHING or all-veneer plywood APA RATED SIDING (and other APA RATED SIDING panels that qualify on a proprietary basis) can be used in shear wall design. The data presented here give maximum shears for walls with APA RATED SHEATHING, with plywood APA RATED SIDING installed directly to studs (APA Sturd-I-Wall), and with panels applied over gypsum sheathing for walls required to be fire rated from the outside.

To design a shear wall, follow these steps.

1. Determine the unit shear transferred by the roof diaphragm to the wall. This generally will be one-fourth the area of the adjacent wall, multiplied by the wind load, divided by the length of the shear wall being designed (subtract length of large openings).
2. Determine the required panel grade and thickness, and nailing schedule from [Table 25](#). Check anchor bolts in sill plate for shear.
3. Check wall framing on each end of shear wall and design foundation anchor if required ([see Figure 20](#)).

Design data for roof diaphragms are given on pages [61](#) and [62](#). For complete information on shear walls and diaphragms, write for [APA Design/Construction Guide: Diaphragms and Shear Walls, Form L350](#).

FIGURE 20

SHEAR WALL FOUNDATION ANCHOR

High shear wall overturning moments may be transferred by a fabricated steel bracket such as this. Regular foundation bolts may be all that is required in some cases.

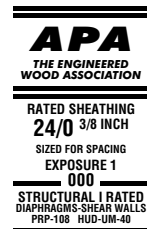
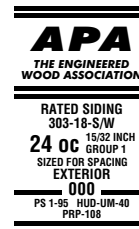
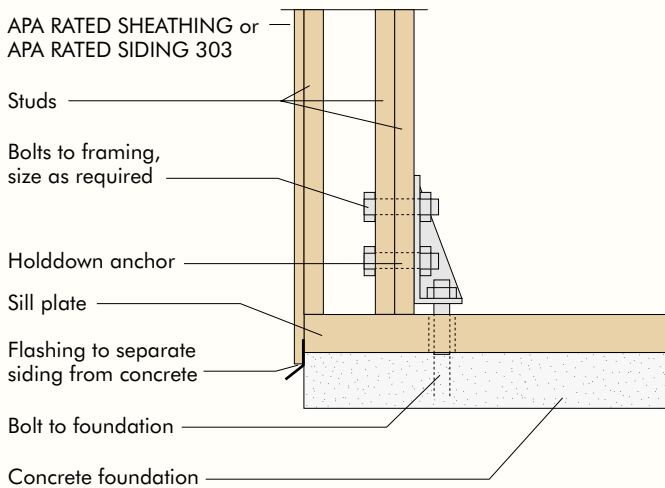

TABLE 25

ALLOWABLE SHEAR (POUNDS PER FOOT) FOR APA PANEL SHEAR WALLS WITH FRAMING OF DOUGLAS-FIR, LARCH, OR SOUTHERN PINE^(a) FOR WIND OR SEISMIC LOADING^(b,h,i,i) (See also IBC Table 2306.4.1)

Panel Grade	Minimum Nominal Panel Thickness (in.)	Minimum Nail Penetration in Framing (in.)	Nail Size (common or galvanized box) ^(k)	Panels Applied Direct to Framing				Panels Applied Over 1/2" or 5/8" Gypsum Sheathing				
				Nail Spacing at Panel Edges (in.)				Nail Size (common or galvanized box)	Nail Spacing at Panel Edges (in.)			
				6	4	3	2 ^(e)		6	4	3	2 ^(e)
APA STRUCTURAL I grades	5/16	1-1/4	6d	200	300	390	510	8d	200	300	390	510
	3/8			230 ^(d)	360 ^(d)	460 ^(d)	610 ^(d)					
	7/16	1-3/8	8d	255 ^(d)	395 ^(d)	505 ^(d)	670 ^(d)	10d	280	430	550 ^(f)	730
	15/32			280	430	550	730					
	15/32	1-1/2	10d	340	510	665 ^(f)	870					
APA RATED SHEATHING; APA RATED SIDING ^(g) and other APA grades except species Group 5	5/16 or 1/4 ^(c)			180	270	350	450		180	270	350	450
	3/8	1-1/4	6d	200	300	390	510	8d	200	300	390	510
	3/8			220 ^(d)	320 ^(d)	410 ^(d)	530 ^(d)					
	7/16	1-3/8	8d	240 ^(d)	350 ^(d)	450 ^(d)	585 ^(d)	10d	260	380	490 ^(f)	640
	15/32			260	380	490	640					
	15/32	1-1/2	10d	310	460	600 ^(f)	770					
APA RATED SIDING ^(g) and other APA grades except species Group 5	5/16 ^(c)	1-1/4	6d	140	210	275	360	8d	140	210	275	360
	3/8	1-3/8	8d	160	240	310	410	10d	160	240	310 ^(f)	410

- (a) For framing of other species: (1) Find specific gravity for species of lumber in the AF&PA National Design Specification. (2) For common or galvanized box nails, find shear value from table above for nail size for actual grade. (3) Multiply value by the following adjustment factor: Specific Gravity Adjustment Factor = [1 - (0.5 - SG)], where SG = specific gravity of the framing. This adjustment shall not be greater than 1.
- (b) All panel edges backed with 2-inch nominal or wider framing. Install panels either horizontally or vertically. Space nails maximum 6 inches o.c. along intermediate framing members for 3/8-inch and 7/16-inch panels installed on studs spaced 24 inches o.c. For other conditions and panel thicknesses, space nails maximum 12 inches o.c. on intermediate supports. Fasteners shall be located 3/8 inch from panel edges.
- (c) 3/8-inch or APA RATED SIDING 16 oc is minimum recommended when applied direct to framing as exterior siding.
- (d) Shears may be increased to values shown for 15/32-inch sheathing with same nailing provided (1) studs are spaced a maximum of 16 inches o.c., or (2) if panels are applied with strength axis across studs.
- (e) Framing at adjoining panel edges shall be 3-inch nominal or wider, and nails shall be staggered where nails are spaced 2 inches o.c. Check local code for variations of these requirements.

- (f) Framing at adjoining panel edges shall be 3-inch nominal or wider, and nails shall be staggered where 10d nails (3" x 0.148") having penetration into framing of more than 1-1/2 inches are spaced 3 inches o.c. Check local code for variations of these requirements.
- (g) Values apply to all-veneer plywood APA RATED SIDING panels only. Other APA RATED SIDING panels may also qualify on a proprietary basis. APA RATED SIDING 16 oc plywood may be 11/32 inch, 3/8 inch or thicker. Thickness at point of nailing on panel edges governs shear values.
- (h) Where panels are applied on both faces of a wall and nail spacing is less than 6 inches o.c. on either side, panel joints shall be offset to fall on different framing members. Or framing shall be 3 inch nominal or thicker and nails on each side shall be staggered.
- (i) In Seismic Design Category D, E, or F, where shear design values exceed 490 pounds per lineal foot (LRFD) or 350 pounds per lineal foot (ASD) all framing members receiving edge nailing from abutting panels shall not be less than a single 3-inch nominal member. Plywood joint and sill plate nailing shall be staggered in all cases. See IBC Section 2305.3.10 for sill plate side and anchorage requirements.
- (j) Galvanized nails shall be hot dip or tumbled.
- (k) See Table 5, page 13, for nail dimensions.

Typical Layout for Shear Walls





ROOF CONSTRUCTION

APA Panel Roof Sheathing

The recommendations for roof sheathing in [Table 26](#) apply to APA RATED SHEATHING Exposure 1, Exposure 2 or Exterior, and APA STRUCTURAL I RATED SHEATHING Exposure 1 or Exterior. Uniform load deflection limits are 1/180 of span under live load plus dead load, and 1/240 under live load only. Special conditions, such as heavy concentrated loads, may require constructions in excess of these minimums, or allowable live loads may have to be decreased for dead loads greater than 10 psf, such as tile roofs. **Panels are assumed continuous over two or more spans with the long dimension or strength axis across supports.**

Note: The Span Rating in the trademark applies when the long panel dimension or strength axis is across supports unless the strength axis is otherwise identified.

TABLE 26

RECOMMENDED UNIFORM ROOF LIVE LOADS FOR APA RATED SHEATHING^(c) AND APA RATED STURD-I-FLOOR WITH STRENGTH AXIS PERPENDICULAR TO SUPPORTS^(e)

Panel Span Rating	Minimum Panel Thickness (in.)	Maximum Span (in.)		Allowable Live Loads (psf) ^(d)							
		With Edge Support ^(a)	Without Edge Support	Spacing of Supports Center-to-Center (in.)							
				12	16	20	24	32	40	48	60
APA RATED SHEATHING ^(c)											
12/0	5/16	12	12	30							
16/0	5/16	16	16	70	30						
20/0	5/16	20	20	120	50	30					
24/0	3/8	24	20 ^(b)	190	100	60	30				
24/16	7/16	24	24	190	100	65	40				
32/16	15/32, 1/2	32	28	325	180	120	70	30			
40/20	19/32, 5/8	40	32	—	305	205	130	60	30		
48/24	23/32, 3/4	48	36	—	—	280	175	95	45	35	
60/32 ^(g)	7/8	60	40	—	—	—	305	165	100	70	35
60/48 ^(g)	1-1/8	60	48	—	—	—	305	165	100	70	35
APA RATED STURD-I-FLOOR ^(f)											
16 oc	19/32, 5/8	24	24	185	100	65	40				
20 oc	19/32, 5/8	32	32	270	150	100	60	30			
24 oc	23/32, 3/4	48	36	—	240	160	100	50	30	25	
32 oc	7/8	48	40	—	—	295	185	100	60	40	
48 oc	1-3/32, 1-1/8	60	48	—	—	—	290	160	100	65	40

(a) Tongue-and-groove edges, panel edge clips (one midway between each support, except two equally spaced between supports 48 inches on center or greater), lumber blocking, or other. For low slope roofs, see Table 27.

(b) 20 inches for 3/8-inch and 7/16-inch panels. 24 inches for 15/32-inch and 1/2-inch panels.

(c) Includes APA RATED SHEATHING/CEILING DECK.

(d) 10 psf dead load assumed.

(e) Applies to panels 24 inches or wider applied over two or more spans.

(f) Also applies to C-C Plugged grade plywood.

(g) Check with supplier for availability.

Good performance of built-up, single-ply, or modified bitumen roofing applied on low slope roofs requires a stiffer deck than does prepared roofing applied on pitched roofs. Although APA Span-Rated panels used as roof sheathing at maximum span are adequate structurally, an upgraded system is recommended for low slope roofs. Table 27 provides recommended maximum spans for low slope roof decks. Recommended live loads can be determined from Table 26, and minimum fastener requirements are given in Table 28. Increased nail schedules may be required in high wind zones. Recommended nail schedules for high wind zones are described in *APA Data File, Roof Sheathing Fastening Schedules for Wind Uplift, Form T325*, available from APA.

TABLE 27

RECOMMENDED MAXIMUM SPANS FOR APA PANEL ROOF DECKS FOR LOW SLOPE ROOFS^(a) (Panel strength axis perpendicular to supports and continuous over two or more spans)

Grade	Minimum Nominal Panel Thickness (in.)	Minimum Span Rating	Maximum Span (in.)	Panel Clips Per Span ^(b) (number)
APA RATED SHEATHING	15/32	32/16	24	1
	19/32	40/20	32	1
	23/32	48/24	48	2
APA RATED STURD-I-FLOOR	7/8	60/32	60	2
	19/32	20 oc	24	1
	23/32	24 oc	32	1
	7/8	32 oc	48	2

(a) Low slope roofs are applicable to built-up, single-ply and modified bitumen roofing systems. For guaranteed or warranted roofs contact membrane manufacturer for acceptable deck. Low-slope roofs

have a slope that is less than 2/12 (2"/foot).

(b) Edge support may also be provided by tongue-and-groove edges or solid blocking.

FIGURE 21

APA PANEL ROOF SHEATHING

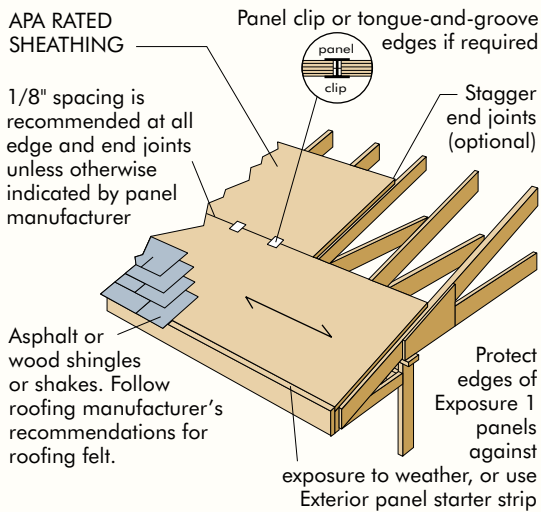

Note: Cover sheathing as soon as possible with roofing felt for extra protection against excessive moisture prior to roofing application.

Note: For pitched roofs, place screened surface or side with skid-resistant coating up if OSB panels are used. Keep roof surface free of dirt, sawdust and debris, and wear skid-resistant shoes when installing roof sheathing.

Note: For buildings with conventionally framed roofs (trusses or rafters), limit the length of continuous sections of roof area to 80 feet maximum during construction, to allow for accumulated expansion in wet weather conditions. Omit roof sheathing panels in each course of sheathing between sections, and install "fill in" panels later to complete roof deck installation prior to applying roofing.

TABLE 28

RECOMMENDED MINIMUM FASTENING SCHEDULE FOR APA PANEL ROOF SHEATHING (Increased nail schedules may be required in high wind zones and where roof is engineered as a diaphragm.)

Panel Thickness ^(b) (in.)	Size ^(f)	Nailing ^{(c)(d)}	
		Supported Panel Edges ^(e)	Maximum Spacing (in.)
5/16 - 1	8d	6	12 ^(a)
1-1/8	8d or 10d	6	12 ^(a)

- (a) For spans 48 inches or greater, space nails 6 inches at all supports.
- (b) For stapling asphalt shingles to 5/16-inch and thicker panels, use staples with a 15/16-inch minimum crown width and a 1-inch leg length. Space according to shingle manufacturer's recommendations.
- (c) Use common smooth or deformed shank nails with panels to 1 inch thick. For 1-1/8-inch panels, use 8d ring- or screw-shank or 10d common smooth-shank nails.
- (d) Other code-approved fasteners may be used.
- (e) Supported panel joints shall occur approximately along the centerline of framing with a minimum bearing of 1/2". Fasteners shall be located 3/8 inch from panel edges.
- (f) See Table 5, page 13, for nail dimensions.

Note: Gluing of roof sheathing to framing is not recommended, except when recommended by the adhesive manufacturer for roof sheathing that already has been permanently protected by roofing.

APA RATED SHEATHING is equally effective under built-up roofing, asphalt or fiberglass shingles, tile roofing, or wood shingles or shakes. Roof trusses spaced 24 inches on center are widely recognized as the most economical construction for residential roofs. However, using fewer supports with thicker panels – e.g., 23/32- or 3/4-inch 48/24 panels over framing 48 inches on center – is also cost effective for long-span flat or pitched roofs. Recommended live loads are given in [Table 26](#). Nailing recommendations are given in [Table 28](#).

When support spacing exceeds the maximum length of an unsupported edge (see [Table 26](#)), provide adequate blocking, tongue-and-groove edges, or other edge support such as panel clips. Some types of panel clips, in addition to edge support, automatically assure proper panel spacing. When required, use one panel clip per span, except use two clips for 48-inch or longer spans.

See [APA's Build A Better Home: Roofs, Form A535](#), for additional recommended details to prevent moisture infiltration in roofs.

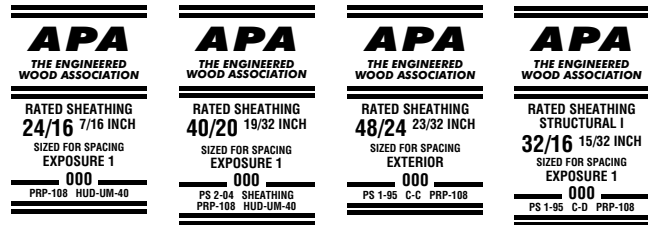

Preframed Roof Panels

Spans of 8 to 12 feet are usually the most practical with preframed panel construction, although spans to 30 feet are not uncommon. Unsanded 4x8-foot APA panels with stiffeners preframed at 16 or 24 inches on center ([Figure 22](#)) are common. The long dimension or strength axis of the panel typically runs parallel to supports. Stiffeners and roof purlins provide support for all panel edges. Minimum nailing requirements for preframed panels are the same as for roof sheathing.

In preframed panels 8x8 feet or larger ([Figure 23](#)), the panel strength axis may run either parallel or perpendicular to stiffeners spaced 16 or 24 inches on center. Placing the strength axis across supports may require edge support such as panel clips or cleats between stiffeners at mid span in accordance with [Table 26](#). Recommendations in [Table 29](#) are based on long dimension or strength axis of the panel parallel to supports. Deflection limits are 1/180 of the span for total load; 1/240 for live load only. See [Table 30](#) for design information on stiffeners for preframed panels. Nailing requirements for preframed panels are the same as for roof sheathing.

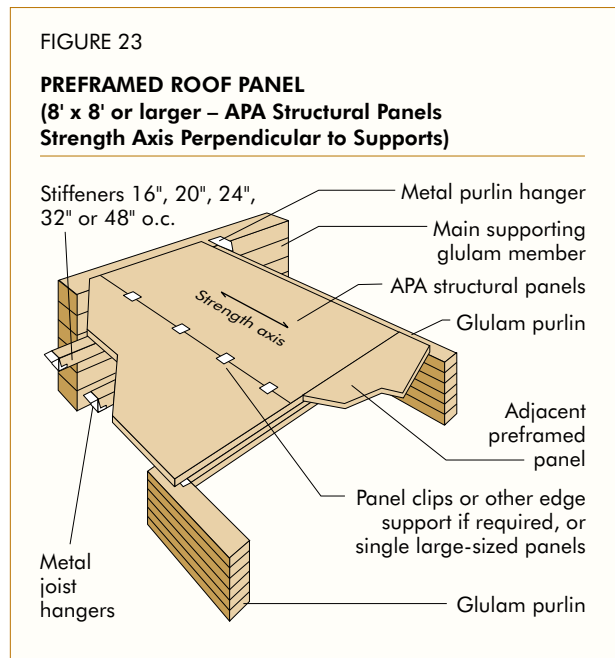
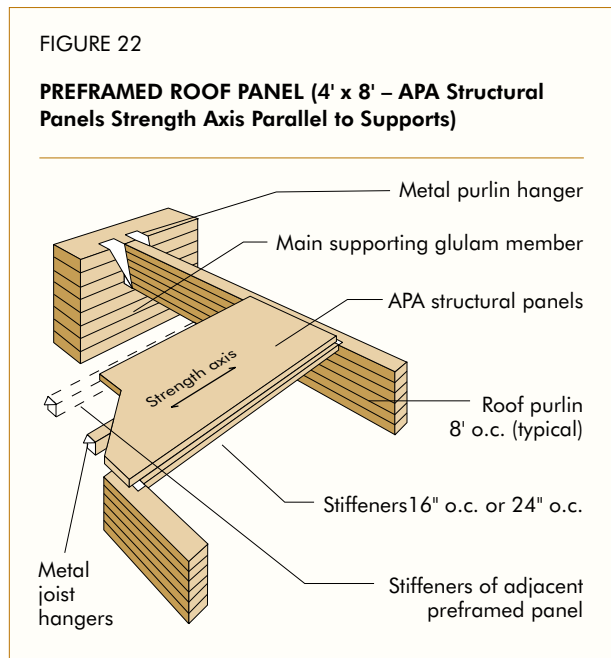

TABLE 29

RECOMMENDED ROOF LOADS (PSF) FOR APA RATED SHEATHING WITH STRENGTH AXIS PARALLEL TO SUPPORTS^{(e)(f)} (OSB, composite and 5-ply/5-layer plywood panels unless otherwise noted)

Panel Grade	Thickness (in.)	Span Rating	Maximum Span (in.)	Load at Maximum Span	
				Live	Total
APA STRUCTURAL I RATED SHEATHING	7/16	24/0, 24/16	24 ^(d)	20	30
	15/32	32/16	24	35 ^(a)	45 ^(a)
	1/2	32/16	24	40 ^(a)	50 ^(a)
	19/32, 5/8	40/20	24	70	80
	23/32, 3/4	48/24	24	90	100
APA RATED SHEATHING	7/16 ^(b)	24/0, 24/16	16	40	50
	15/32 ^(b)	32/16	24 ^(d)	20	25
	1/2 ^(b)	24/0, 32/16	24 ^(d)	25	30
	19/32	40/20	24	40 ^(c)	50 ^(c)
	5/8	32/16, 40/20	24	45 ^(c)	55 ^(c)
	23/32, 3/4	40/20, 48/24	24	60 ^(c)	65 ^(c)

(a) For 4-ply plywood marked PS 1, reduce load by 15 psf.

(b) Composite panels must be 19/32 inch or thicker.

(c) For composite and 4-ply plywood panels, reduce load by 15 psf.

(d) Solid blocking recommended at panel ends for 24-inch span.

(e) For guaranteed or warranted roofs, contact membrane manufacturer for acceptable deck.

(f) Provide edge support.

TABLE 30

STIFFENER LOAD-SPAN TABLES FOR PREFRAMED APA PANEL ROOF DECKS

Douglas Fir-Larch		Allowable Roof Live Load (psf) ^(a)											
Center-to-Center Purlin Spacing ^(b) (ft)	Stiffener Size and Spacing (in.)	Select Structural			No. 1 & Better			No. 1			No. 2		
		Strength ^(d)			Strength ^(d)			Strength ^(d)			Strength ^(d)		
		Defl. ^(c)	1.15	1.25	Defl. ^(c)	1.15	1.25	Defl. ^(c)	1.15	1.25	Defl. ^(c)	1.15	1.25
8	2 x 4 @ 16	37	67	73	35	51	57	33	41	46	31	36	40
	2 x 4 @ 24	23	41	46	21	31	34	19	24	27	18	21	23
	2 x 6 @ 16	144	154	168	136	121	133	129	99	109	121	88	97
	2 x 6 @ 24	96	99	109	91	78	85	86	63	69	81	56	61
	2 x 6 @ 32	72	61	68	68	47	52	64	38	42	61	33	37
Southern Pine		Allowable Roof Live Load (psf) ^(a)											
Center-to-Center Purlin Spacing ^(b) (ft)	Stiffener Size and Spacing (in.)	Select Structural			No. 1 Dense			No. 1			No. 2		
		Strength ^(d)			Strength ^(d)			Strength ^(d)			Strength ^(d)		
		Defl. ^(c)	1.15	1.25	Defl. ^(c)	1.15	1.25	Defl. ^(c)	1.15	1.25	Defl. ^(c)	1.15	1.25
8	2 x 4 @ 16	35	87	96	35	58	64	33	53	59	31	41	46
	2 x 4 @ 24	21	55	60	21	35	39	19	32	36	18	24	27
	2 x 6 @ 16	136	205	223	136	137	150	129	129	141	121	95	104
	2 x 6 @ 24	91	133	146	91	88	97	86	83	91	81	60	66
	2 x 6 @ 32	68	83	91	68	54	60	64	50	56	61	36	40

(a) Final allowable load is the lesser of the loads as determined by deflection and stress.

(b) Actual span of stiffeners taken as 3-1/2 inches less than center-to-center spacing of purlins.

(c) Deflection limitations: Span/240 under live load only; Span/180 under total load, assuming a dead load of 10 psf.

(d) Loads limited by stress are based on two conditions of duration of load: 2 months, such as for snow (1.15); and 7 days (1.25); includes effects of 10 psf dead load.

Long Span Systems

Both preframed panel systems and direct application of sheathing to secondary or primary framing are common approaches in long span roof construction. Bay spacing and type of framing govern the choice.



Experience shows that panels over supports 48 inches on center often yield maximum economy. Panels with a Span Rating of 48/24 are good for at least 35 psf snow load and meet the requirements for most guaranteed or warranted roofs.

FIGURE 24

TYPICAL CONNECTIONS TO ENGINEERED FLAT ROOF MEMBERS

Panels Nailed to Wood I-Joist

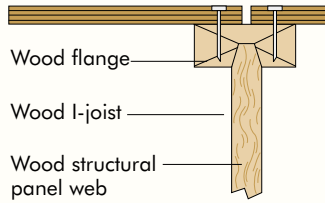

Panels Nailed to Open-Web Parallel-Chord Wood Truss

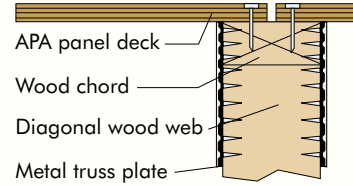

Panels Nailed to Nailer Bolted to Steel Joist

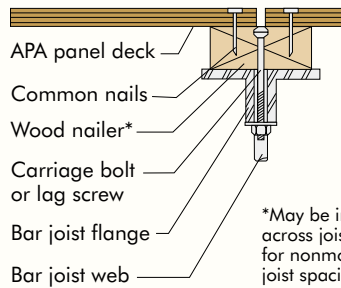

*May be installed across joists (good for nonmodular joist spacing).

Panels Nailed to Glulam Beam

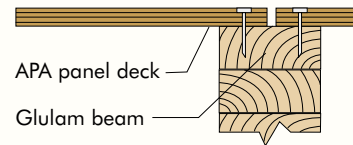

Figure 24 illustrates typical connections for engineered flat roof members.

Plywood Under Special Coatings

Chemical coatings for roofs have increased the range of design possibilities, particularly in larger commercial structures with contoured or steeply pitched roof surfaces exposed to view.

The plywood thickness and span recommendations in [Table 31](#) for plywood under special coatings assume installation with the **long dimension or strength axis of the panel perpendicular to supports** and liquid coatings applied directly to the plywood. Check local building codes for any required deviations from these recommendations. Allowable roof live load is based on the same deflection criteria as described in [Table 26](#) for APA panel roof sheathing.

TABLE 31

PLYWOOD THICKNESS AND MAXIMUM SPANS FOR ROOF DECKS UNDER SPECIAL COATINGS^(c)

Grade	Minimum Plywood Thickness (in.)	Maximum Support Spacing (in.)			Nail Type & Size ^{(b)(e)}	Maximum Nail Spacing (in.)	
		Group 1	Groups 2 & 3	Group 4		Supported Panel Edges	Intermediate Supports
	11/32	16	—	—	8d common smooth ^(a) or ring- or screw-shank	6	12
APA A-C EXT	15/32, 1/2	24	24	16	8d common smooth ^(a) or ring- or screw-shank	6	12
APA B-C EXT	19/32, 5/8	32	24	24	8d ring- or screw-shank	6	12
APA C-C PLUGGED EXT	23/32, 3/4	40	32	32	8d ring- or screw-shank	6	12
	7/8	48	40	40	8d ring- or screw-shank	6	12 ^(d)

(a) Use only deformed-shank nails for curved surfaces.

(b) Nail type, size and spacing may vary for engineered diaphragm designs.

(c) All panels will support at least 30 psf live load plus 10 psf dead load at maximum span.

(d) For spans 48 inches or greater, space nails maximum 6 inches at all supports.

(e) See [Table 5, page 13](#), for nail dimensions.

Exterior plywood is recommended for use under special coatings for roofs. Where the coating requires a very smooth base, use APA A-C Exterior or APA B-C Exterior plywood. Where maximum smoothness is not essential, use APA C-C PLUGGED Exterior. Tongue-and-groove plywood (1/2 inch or thicker) or lumber blocking at panel edges is recommended. A 1/8-inch space is recommended at all edge and end joints unless otherwise indicated by panel manufacturer. If high-performance coatings are to be used for finish, check coating manufacturer's recommendations for panel joint treatment. Nail size, type and spacing recommendations are also given in [Table 31](#).

Grades recommended in [Table 31](#) should also be specified for the top layer when the structural wood deck is to be overlaid with a separate plywood layer to serve as substrate for special roof coatings. A 1/8-inch space is recommended at all edge and end joints unless otherwise indicated by panel manufacturer. Although minimum 1/4-inch plywood may be used over structural decks, 15/32 inch or thicker panels should be considered for best performance over uneven surfaces or when rain or high humidity is anticipated prior to application of roof coating. Use corrosion-resistant fasteners sized and spaced as recommended in [Table 10](#).

APA Panel Soffits

Recommended spans for open and closed APA panel soffits are given in [Tables 32 and 33](#). The recommendations in [Table 32](#) for open soffits also apply to combined roof/ceiling construction. **Panels are assumed continuous over two or more spans with the long dimension or strength axis across supports** for both applications. For appearance purposes in open soffit construction, provide blocking, tongue-and-groove edges, or other suitable edge support. Panels will support at least 30 psf live load, plus 10 psf dead load.

For open soffit and nonstructural ceiling construction, panels designated Exposure 1 are recommended as a minimum (check local building code) where appearance is not a major consideration.

TABLE 32

APA PANELS FOR OPEN SOFFIT OR FOR COMBINED ROOF DECKING-CEILING^{(a)(b)}
(Strength axis across supports. For APA RATED SHEATHING, where appearance is not a major concern, see Table 26.)

Maximum Span (inches)	Panel Description (All panels Exterior or Exposure 1)	Species Group for Plywood
16	15/32" APA RATED SIDING 303	1, 2, 3, 4
	15/32" APA MDO, Sanded and Touch-Sanded Plywood	1, 2, 3, 4
24	15/32" APA RATED SIDING 303	1
	15/32" APA MDO, Sanded and Touch-Sanded Plywood	1, 2, 3
	19/32" APA RATED SIDING 303	1, 2, 3, 4
	19/32" APA MDO, Sanded and Touch-Sanded Plywood	1, 2, 3, 4
32	APA RATED STURD-I-FLOOR 16 oc	—
	19/32" APA RATED SIDING 303	1
	19/32" APA MDO, Sanded and Touch-Sanded Plywood	1
	23/32" APA Textured Plywood ^(c)	1, 2, 3, 4
	23/32" APA MDO, Sanded and Touch-Sanded Plywood	1, 2, 3, 4
48	APA RATED STURD-I-FLOOR 20 oc	—
	1-1/8" APA Textured Plywood ^(c)	1, 2, 3, 4
	APA RATED STURD-I-FLOOR 48 oc	—

(a) All panels will support at least 30 psf live load plus 10 psf dead load at maximum span.

(b) For appearance purposes, blocking, tongue-and-groove edges or other suitable edge supports should be provided.

(c) Also see Table 26 for APA RATED SHEATHING/CEILING DECK.

TABLE 33

APA PANELS FOR CLOSED SOFFIT OR FOR NONSTRUCTURAL CEILING^{(a)(c)} (Strength axis across supports)

Maximum Span (in.) All Edges Supported	Nominal Panel Thickness	Species Group	Nail Size and Type ^{(a)(d)}
24	11/32" APA ^(b)	All Species Groups	6d nonstaining box or casing
32	15/32" APA ^(b)		8d nonstaining box or casing
48	19/32" APA ^(b)		8d nonstaining box or casing

(a) Space nails maximum 6 inches at panel edges and 12 inches at intermediate supports for spans less than 48 inches; 6 inches at all supports for 48-inch spans.

(b) Any suitable grade panel which meets appearance requirements – Exterior for closed soffits, Exposure 1 or Exterior for nonstructural ceiling.

(c) For appearance purposes, blocking, tongue-and-groove edges or other suitable edge supports should be provided.

(d) See Table 5, page 13, for nail dimensions.

Only Exterior panels should be used for closed soffits.

At eaves where Exposure 1 sheathing is used for roof decking, protect panel edges against direct exposure to the weather with fascia trim.

Although unsanded and touch-sanded grades of plywood are often used for applications such as soffits, optimum appearance and finish performance is attained by using panels with textured or sanded A-grade faces. For panel grades other than APA RATED SIDING 303, top-quality acrylic latex house paint systems provide best performance (see page 50). Face-checking (separations between fibers parallel to the grain of the face veneer) can be expected on non-overlaid plywood which is exposed to the outdoors, even when finished. If a smooth, check-free surface is desired, use Medium Density Overlay (MDO) plywood.

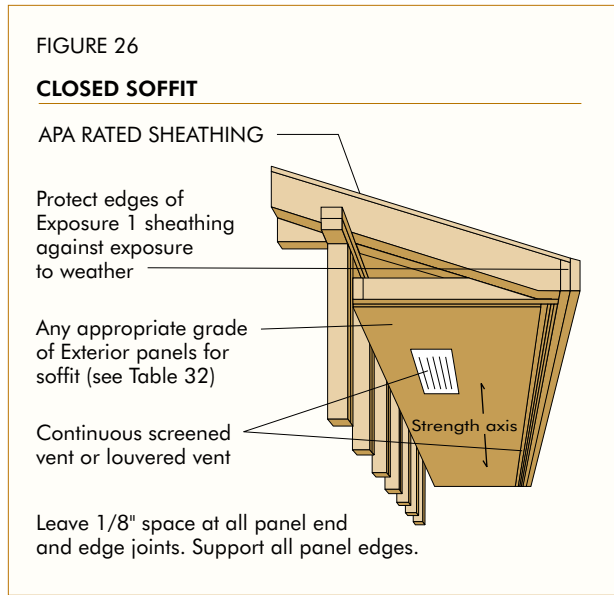
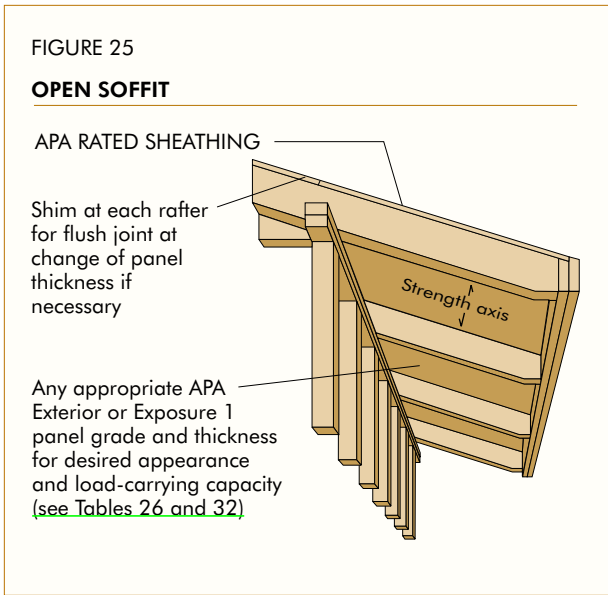

APA Panel Roof Diaphragms

With only slight design modifications, any APA panel roof deck system described in the previous sections will also function as an engineered diaphragm to resist high wind and seismic loading. A diaphragm’s ability to function effectively as a beam, transferring lateral loads to shear walls, is related to the quality of the connections. Nailing is critical since shear loads are transmitted through these fasteners. Common nails provide required strength. Other nail types may be used when their lateral bearing values are considered in the design. Load-carrying capacity is highest when the diaphragm is blocked. Where 1-1/8" roof panels are desired, such as for Heavy Timber construction (see page 66), shear values for 19/32" panels are used. Blocked shear values for 1-1/8" panels may be obtained by specifying stapled T&G edges. Staples shall be 16 gauge, 1" long with a 3/8" crown, driven through the T&G edges 3/8" from the joint so as to penetrate the tongue. Staples shall be spaced at one-half of the boundary nail spacing for Cases 1 and 2, and at one-third the boundary nail spacing for Case 3 through 6, as illustrated in Table 34. Table 34 gives panel and fastening recommendations for roof diaphragms. Panels and framing are assumed already designed for perpendicular loads. To design a diaphragm, follow these steps:

1. Determine lateral loads and resulting shears.
2. Determine nailing schedule (Table 34). Consider load direction with respect to joints.
3. Compute chord stress due to bending moment. Provide adequate splices. Check deflection. Check anchorage of boundary framing (e.g., chords) to walls.

For information about developing higher diaphragm shears than shown in Table 34, See [Diaphragms and Shear Walls, APA Form L350](#).

 RATED SHEATHING 40/20 19/32 INCH SIZED FOR SPACING EXPOSURE 1 000 PRP-108 HUD-UM-40	 RATED SHEATHING STRUCTURAL I 32/16 15/32 INCH SIZED FOR SPACING EXPOSURE 1 000 PS 1-95 C-D PRP-108	 RATED SHEATHING 24/0 3/8 INCH SIZED FOR SPACING EXPOSURE 1 000 STRUCTURAL I RATED DIAPHRAGMS-SHEAR WALLS PRP-108 HUD-UM-40	 RATED SHEATHING 24/16 7/16 INCH SIZED FOR SPACING EXPOSURE 1 000 PS 2-94 SHEATHING PRP-108 HUD-UM-40
--	---	---	--

TABLE 34
Recommended Shear (pounds per foot) for Horizontal APA Panel Diaphragms with
Framing of Douglas-fir, Larch or Southern Pine^(a) for Wind or Seismic Loading

Panel Grade	Common Nail Size ^(f)	Minimum Nail Penetration in Framing (inches)	Minimum Nominal Panel Thickness (inch)	Minimum Nominal Width of Framing Member (inches)	Blocked Diaphragms				Unblocked Diaphragms		
					Nail Spacing (in.) at diaphragm boundaries (all cases), at continuous panel edges parallel to load (Cases 3 & 4), and at all panel edges (Cases 5 & 6) ^(b)				Nails Spaced 6" max. at Supported Edges ^(b)		
					6	4	2-1/2 ^(c)	2 ^(c)	Case 1 (No unblocked edges or continuous joints parallel to load)		All other configurations (Cases 2, 3, 4, 5 & 6)
					Nail Spacing (in.) at other panel edges (Cases 1, 2, 3 & 4) ^(b)				6	6	
APA STRUCTURAL I grades	6d ^(e)	1-1/4	5/16	2	185	250	375	420	165	125	
				3	210	280	420	475	185	140	
	8d	1-3/8	3/8	2	270	360	530	600	240	180	
				3	300	400	600	675	265	200	
10d ^(d)	1-1/2	15/32	2	320	425	640	730	285	215		
			3	360	480	720	820	320	240		
APA RATED SHEATHING APA RATED STURD-I-FLOOR and other APA grades except Species Group 5	6d ^(e)	1-1/4	5/16	2	170	225	335	380	150	110	
				3	190	250	380	430	170	125	
			3/8	2	185	250	375	420	165	125	
				3	210	280	420	475	185	140	
	3/8	2	240	320	480	545	215	160			
			3	270	360	540	610	240	180		
	8d	1-3/8	7/16	2	255	340	505	575	230	170	
				3	285	380	570	645	255	190	
	15/32	2	270	360	530	600	240	180			
			3	300	400	600	675	265	200		
10d ^(d)	1-1/2	15/32	2	290	385	575	655	255	190		
			3	325	430	650	735	290	215		
19/32	2	320	425	640	730	285	215				
		3	360	480	720	820	320	240			

- (a) For framing of other species: (1) Find specific gravity for species of lumber in the AFPA National Design Specification. (2) Find shear value from table above for nail size for actual grade. (3) Multiply value by the following adjustment factor: Specific Gravity Adjustment Factor = [1 - (0.5 - SG)], where SG = specific gravity of the framing. This adjustment shall not be greater than 1.
- (b) Space nails maximum 12 inches o.c. along intermediate framing members (6 in. o.c. when supports are spaced 48 in. o.c. or greater). Fasteners shall be located 3/8 inch from panel edges.
- (c) Framing at adjoining panel edges shall be 3-in. nominal or wider, and nails shall be staggered where nails are spaced 2 inches o.c. or 2-1/2 inches o.c.

- (d) Framing at adjoining panel edges shall be 3-in. nominal or wider, and nails shall be staggered where 10d nails having penetration into framing of more than 1-5/8 inches are spaced 3 inches o.c.
- (e) 8d is recommended minimum for roofs due to negative pressures of high winds.
- (f) See Table 5, page 13, for nail dimensions.

Notes: Design for diaphragm stresses depends on direction of continuous panel joints with reference to load, not on direction of long dimension or strength axis of sheet. Continuous framing may be in either direction for blocked diaphragms.

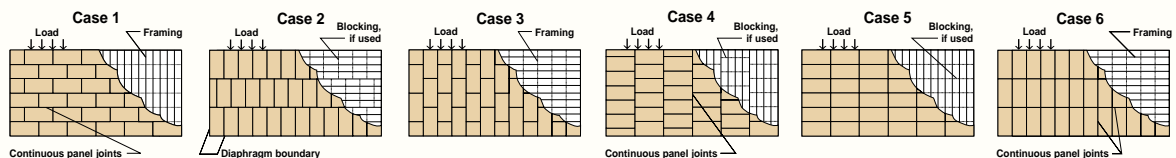



BUILDING REQUIREMENTS AND RELATED PANEL SYSTEMS

Fire-resistant Construction

Protected Construction

Protected construction includes typical floor-ceiling, roof-ceiling or wall assemblies with wood structural panels fastened to wood or steel framing, and a fire-resistive material such as gypsum wallboard, plaster or mineral acoustical tile added to give primary protection to framing. The structural panels slow flame passage and temperature rise while reinforcing supports against collapse under load.

Assemblies are rated in fire tests by Underwriters Laboratories (U.L.) and other agencies. Over 40 floor-ceiling (and/or roof-ceiling) systems using wood structural panels are described in the U.L. *Fire Resistance Directory*. They are accepted as rated constructions by most building codes. Two examples of one-hour-rated floor-ceiling assemblies are shown in [Figure 27](#); several two-hour-rated wood framed assemblies also are described in the U.L. Directory.

Building Requirements

In many fire-resistant floor-ceiling assemblies, a two-layer floor system (15/32-inch subfloor and 19/32-inch underlayment) is used, although several have single-layer 5/8-inch or thicker combination subfloor-underlayment panels. Any finish floor material may be used. The International Building Code permits omission of the top panel layer in roof assemblies or where unusable space occurs above (Table 720.1(3)). Plywood siding or wall sheathing in combination with gypsum sheathing and wallboard on studs is recognized by code officials for one-hour load-bearing exterior walls. A typical example – APA RATED SIDING over 5/8-inch Type X gypsum sheathing attached to 2x studs 16 or 24 inches on center – is illustrated in [Figure 28, page 64](#). Under the International Building Code, Section 704.5, the fire-resistive rating for exterior walls applies only to the inside of the wall when separation to the property line is greater than 5 feet. In this common situation, the gypsum sheathing can be omitted under the siding as noted in [Figure 28](#).

Fire-rated protected wall assemblies will qualify for the one-hour rating if other materials are added over the fire-resistive materials. For example, APA RATED SIDING panels or lap siding may be attached to the outside of a rated wall without impairing the rating.

Roof Coverings

The fire resistance ratings of roofing materials are listed as Class A, B, or C in descending order of fire protection afforded. Their use is prescribed by building codes, and also affects insurance rates. Untreated APA RATED SHEATHING panels are recognized as a structural roof deck substrate for rated roof coverings. For individual requirements, see the U.L. *Roofing Materials and Systems Directory*.

FIGURE 27

ONE-HOUR FIRE-RATED COMBUSTIBLE FLOOR/CEILING (OR ROOF/CEILING) ASSEMBLIES

Some rated assemblies incorporate proprietary products. When designing and specifying, check the Underwriters Laboratories Fire Resistance Directory for complete details on a particular assembly. A change in details may affect fire resistance of the assembly.

1. Two-layer floor systems with joists.^(a) For details, see U.L. Design Nos. L001, L003, L004, L005, L006, L201, L202, L206, L208 (1-1/2 hr), L209, L210, L211 (2 hr), L212, L501, L502, L503, L505 (2 hr), L511 (2 hr), L512, L514, L515, L516, L519, L522, L523, L525, L526, L533, L535, L536 (2 hr), L537, L541 (2 hr) and L545. Also see U.L. Designs No. L524 and L527 (1-1/2 hr single layer) with steel joists spaced 24" o.c., and L521 with wood trusses spaced 24" o.c.

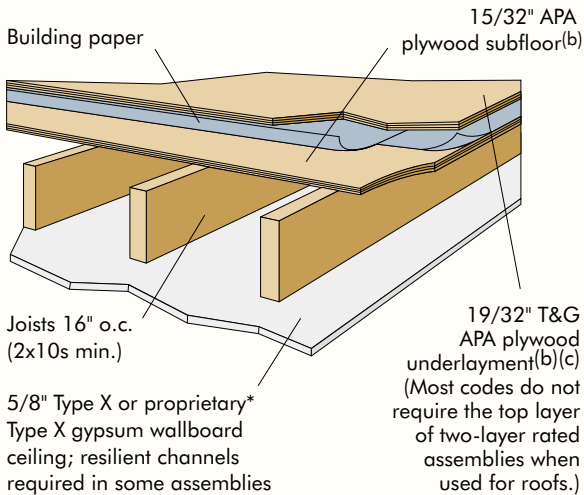

2. Single-layer floor systems with wood I-joists or trusses. For details, see U.L. Design Nos. L528, L529, L534, L542 and L544 (shown), and see 2003 IBC Table 720.1(3), Item 24-1.1 for a single-layer wood I-joist floor/ceiling system. Also see U.L. Design No. L513 for single-layer floor system with lumber joists spaced 24" o.c.

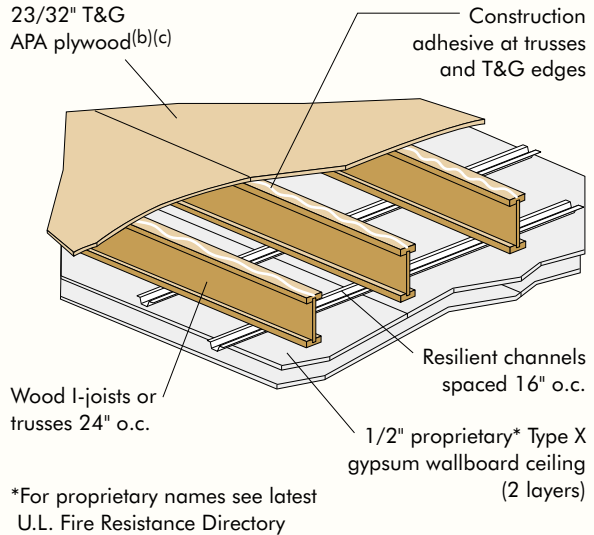

Note:

(a) Substitution of 1-1/8" APA RATED STURD-I-FLOOR 48 oc for the combination of subfloor, paper, and underlayment is often allowed. Check with local building official.

(b) Tests have shown that substitution of OSB or composite APA RATED SHEATHING subfloor and APA RATED STURD-I-FLOOR underlayment for the plywood panels in rated assemblies will not jeopardize fire-resistance ratings. Substitution is based on equivalent panel thickness, except that 7/16" OSB subfloor panels may be used in place of 15/32" plywood subfloor panels in two-layer assemblies. OSB panels are listed as alternates to plywood subflooring or finish flooring in U.L. Design Nos. L501, L503, L505 (2hr), L508, L511 (2hr), L513, L514, L516, L521, L526, L528, L529, L532 (1-1/2 hr), L539, L540, L543, L544, L546, L548, L550, L551 and L552.

(c) Lightweight concrete or gypsum concrete floor topping permitted over single-layer floor or as alternate to plywood underlayment in many assemblies (check details).

For information on fire resistance of APA Rim Board, see *APA Performance Rated Rim Boards, Form W345* and *APA Rim Board in Fire Rated Assemblies, Form D350* at www.apawood.org. For additional information on floor/ceiling fire-rated assemblies, see *APA Design/Construction Guide: Fire Rated Systems, Form W305* at www.apawood.org.

FIGURE 28

ONE-HOUR FIRE-RATED EXTERIOR LOAD-BEARING WALL ASSEMBLY^(a)

- 2x4 studs all 16" or 24" o.c.
- Mineral or glass fiber insulation (optional)
- 5/8" Type X gypsum wallboard
- 5/8" Type X gypsum sheathing^(b)
- Building paper or other code-approved weather-resistive or air infiltration barrier

(a) Generic, non-proprietary assembly based on GA File No. WP8105 listed in Gypsum Association Fire Resistance Design Manual, referenced in the model building codes. Mineral or glass fiber batt insulation (optional).

(b) Exterior layer of gypsum sheathing not required under the National and Standard Building Codes, or the International Building Code, when separation is greater than 5 feet. Check local provisions. See U.L. Design U356 in U.L. *Fire Resistance Directory*.

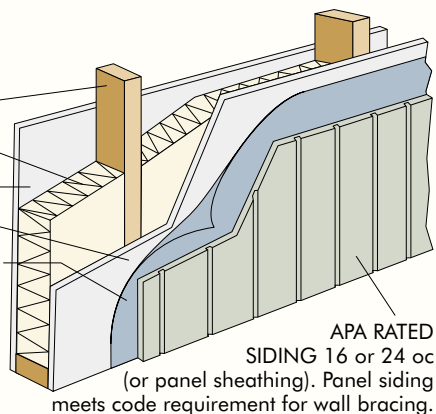

Wall and Ceiling Paneling

The Flame Spread Classification of materials used for interior wall and ceiling finish (and occasionally for other applications) is usually limited by building codes for certain occupancies. Tests have shown that untreated APA wood structural panels will develop flame spread index and smoke index values of 200 or less, which puts them in a Class C (or III) category.

Panels are therefore suitable as interior finish for most applications. Certain more restrictive locations, such as exitways, require a Class A or Class B rating which can be achieved by the use of fire-retardant-treated plywood. (See page 16.)

Structural Glued Laminated Timber (Glulam)

A structural member’s fire resistance is measured by the time it can support its design load during a fire. An exposed beam or column sized for a minimum one-hour fire resistance will support its full design load for at least one hour during standard fire test conditions which simulate an actual fire.

Beams. Glulam beams 6-3/4" and 8-3/4" wide can be adapted to a one-hour fire rating in accordance with procedures recognized by the ICC. For these widths, there is a minimum depth for a one-hour fire rating. The minimum depth increases when the design calls for the beam to be exposed on four rather than three sides. See Table 35.

To adapt beams whose dimensions qualify them for one-hour fire rating, the basic layup is modified as shown in Figure 29. One core lamination from the center of the beam is required by an additional tension lamination.

Columns. Column length determines the minimum size for one-hour ratings. The column size needed for a one-hour fire rating is determined by calculating the ℓ/d and then using the appropriate minimum dimensions; see Table 36.

Columns generally need no special layup to qualify for a one-hour fire rating. For both 8-3/4" and 10-3/4" widths, all columns meeting the minimum size standard satisfy the one-hour fire rating requirement.

As with all structural framing, final specifications of members designed to have one-hour fire resistance should be carefully checked by a professional engineer or architect to assure compliance with all local building codes.

Metal Connectors. In structures using one-hour rated glulams, supporting metal connectors and fasteners also must be designed to achieve a one-hour fire rating. A 1-1/2" covering of wood, fire-rated (Type X) gypsum wallboard or any coating approved for a one-hour rating provides the needed protection.

For further information, see [EWS Technical Note, Calculating Fire Resistance of Glulam Beams and Columns, Form EWS Y245](#).

TABLE 35

ONE-HOUR FIRE-RATED GLULAM BEAMS – MINIMUM DEPTHS FOR 6-3/4" AND 8-3/4" WIDE BEAMS

Beam Width (inches)	Minimum Depth (inches)	
	3 Sides Exposed	4 Sides Exposed
6-3/4	13-1/2	27
8-3/4	7-1/2	13-1/2

TABLE 36

ONE-HOUR FIRE-RATED GLULAM COLUMNS – MINIMUM DEPTHS FOR 8-3/4" AND 10-3/4" COLUMN WIDTHS

ℓ/d Criteria	Column Width (in.)	Minimum Depth (inches)	
		3 Sides Exposed	4 Sides Exposed
$\ell/d > 11$	8-3/4	15	30
	10-3/4	10-1/2	13-1/2
$\ell/d \leq 11$	8-3/4	9	12
	10-3/4	7-1/2	10-1/2

ℓ = column length in inches.
 d = column least cross-sectional dimension in inches.

FIGURE 29

ONE-HOUR FIRE-RATED GLULAM BEAM (Layup for simple span)

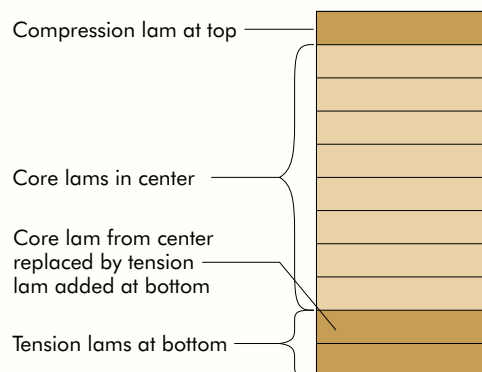

Heavy Timber Construction

Model building codes also recognize Heavy Timber wood construction systems, which can simplify roof or floor construction while providing superior fire resistance. Heavy Timber construction does not constitute one-hour fire resistance, however.

Under fire conditions, large size timber members develop a surface char layer which acts as insulation to slow the burning process. In addition, Heavy Timber construction does not permit concealed wall or ceiling spaces where fire can spread. Years of fire service experience shows that the structural performance of Heavy Timber construction systems under fire conditions is markedly superior to most unprotected “noncombustible” (steel) structures.

See [Table 37](#) for minimum structural member sizes required by model building codes for Heavy Timber construction. Structural glued laminated timber (glulams) also qualifies for Heavy Timber construction systems when members conform to required sizes.

Insurance rating bureaus and all of the model building codes accept 1-1/8-inch tongue-and-groove wood structural panels with exterior glue (Exposure 1) as an alternative to two-inch nominal tongue-and-groove lumber decking in Heavy Timber roof construction.

Typical construction ([Figure 30](#)) consists of tongue-and-groove APA RATED STURD-I-FLOOR 48 oc Exposure 1 (or 1-1/8-inch tongue-and-groove APA RATED SHEATHING Exposure 1 – Check local availability before specifying). Heavy Timber beams must be 4x6 minimum and are normally spaced 48 inches on center. For an exposed ceiling with improved appearance, 1-1/8-inch textured wood structural panels APA RATED SHEATHING/CEILING DECK panels can be specified.

Heavy Timber floors may also be constructed with 15/32-inch wood structural panels over three-inch planks.

For additional information on fire-resistant construction, see *APA Design/Construction Guide: Fire-Rated Systems*, Form W305.

TABLE 37

DIMENSIONS OF COMPONENTS FOR HEAVY TIMBER CONSTRUCTION (TYPICAL CODE PROVISIONS)

Heavy Timber construction is generally defined in building codes and standards by the following minimum sizes for the various members or portions of a building:

	Inches, nominal
Columns – supporting floor loads	
Supporting roof and ceiling loads only	8 x 8
Supporting roof and ceiling loads only	6 x 8
Floor framing	
Beams and girders	6 wide x 10 deep
Arches and trusses	8 in any dimension
Roof framing – not supporting floor loads	
Arches springing from grade	6 x 8 lower half 6 x 6 upper half
Arches, trusses, other framing springing from top of walls, etc.	4 x 6
Floor (covered with 1-inch nominal flooring, 15/32- or 1/2-inch wood structural panels, or other approved surfacing)	
Splined or tongue-and-groove plank	3
Planks set on edge	4
Roof decks	
Splined or tongue-and-groove plank	2
Plank set on edge	3
Tongue-and-groove wood structural panels	1-1/8

FIGURE 30

HEAVY TIMBER ROOF CONSTRUCTION

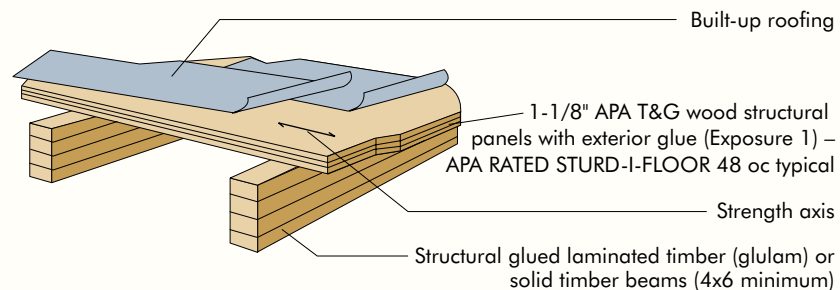

Wind-resistive Roofs

Wind ratings are based on a roof system’s performance in wind uplift tests. Systems meeting U.L. requirements are assigned a semi-wind-resistive classification (Class 30 or 60) or fully-wind-resistive classification (Class 90).

Many of the fire-rated assemblies also can qualify for these ratings. Heavy Timber usually is accorded semi-wind-resistive recognition.

There are over 70 U.L. listed roofing/roof deck systems with plywood sheathing for fully-wind-resistive Class 90 ratings. One of the systems, NM519, is illustrated in [Figure 31](#). Another is NM520, a panelized roof deck of 15/32-inch APA RATED SHEATHING 32/16 Exposure 1 plywood marked PS 1 (CDX, 4 plies minimum, all-Group 1 species) on 2-inch nominal stiffeners spanning eight feet between purlins framed into glulam beams. See [Figure 32](#) for further information. This panelized roof is commonly used for seismic or wind resistance, utilizing the diaphragm shear strength of the plywood.

FIGURE 31

FULLY-WIND-RESISTIVE ROOF ASSEMBLY — U.L. CLASS 90 (NM519)

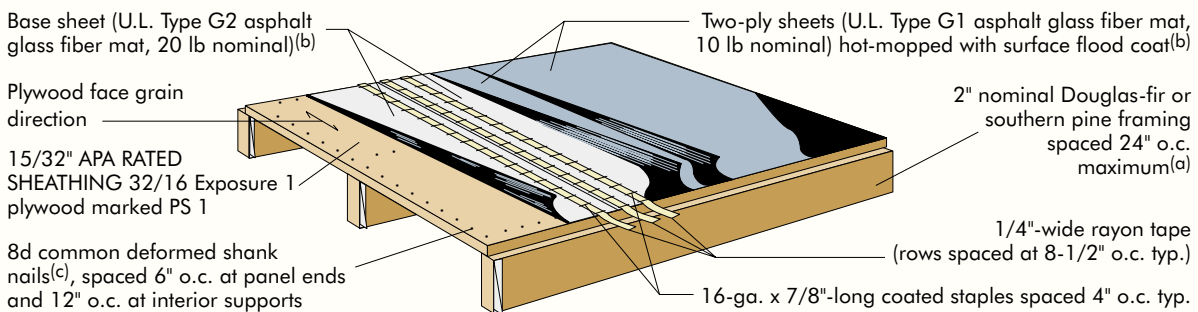

- (a) Design in accordance with local building code requirements for roof loads and anchorage. All framing must have 2" nominal or greater width for plywood deck nailing.
- (b) Install roofing base and ply sheets with roll direction parallel to plywood face grain directions.
- (c) See [Table 5, page 13](#), for nail diameter.

FIGURE 32

FULLY-WIND-RESISTIVE ROOF ASSEMBLY — U.L. CLASS 90 (NM520)

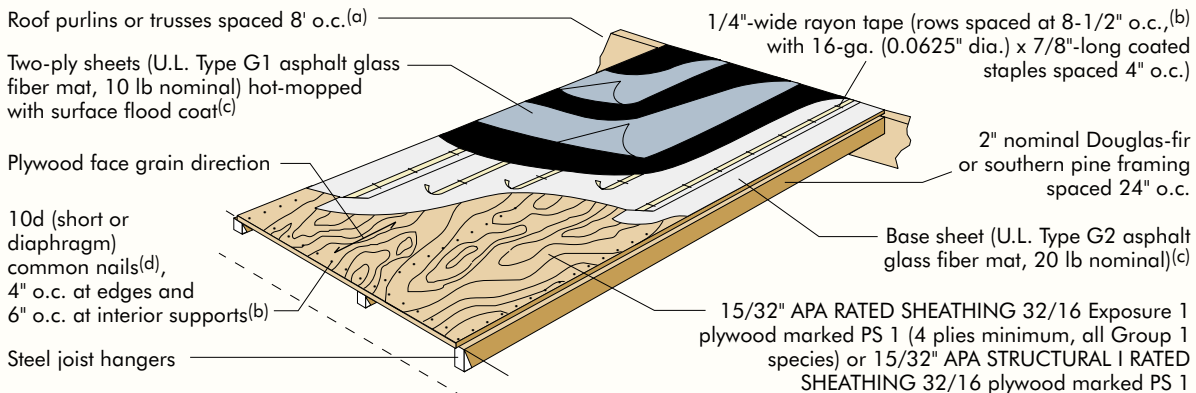

- (a) Trusses or I-joists used for purlins must have chords or flanges of 1-3/4" minimum depth for plywood deck nailing.
- (b) For semi-wind-resistive assemblies (Class 60), plywood deck nailing spaced 6" o.c. at all supports and roofing base sheet attached with rayon tape rows spaced 11-1/3" o.c.
- (c) Install roofing base and ply sheets with roll direction parallel to plywood face grain direction.
- (d) See [Table 5, page 13](#), for nail diameter.

Other fully-wind-resistive Class 90 roof systems with proprietary metal roofing panels, using plywood or OSB panels as a roofing substrate over steel decking, or as structural roof sheathing, also meet U.L. requirements. [See Figure 33.](#)

For additional information, [see *APA Design/Construction Guide: Nonresidential Roof Systems*, Form A310](#) and U.L. *Roof Materials and Systems Directory*.

FIGURE 33

METAL ROOFING PANELS — U.L. CLASS 90^(a)

APA RATED SHEATHING plywood per PS 1 (min. 15/32" for framing spaced 16" o.c.; 19/32", 5/8 or 3/4" for framing spaced 24" o.c.)

Caulk or tape to seal joints (check manufacturers' recommendations)

8d deformed shank nails^(b) or No. 8 x 2" screws @ 6" o.c. at edges and 6" or 12" o.c. at interior supports (for steel framing, No. 6 x 1-1/4" or No. 12 x 1-5/8" screws)

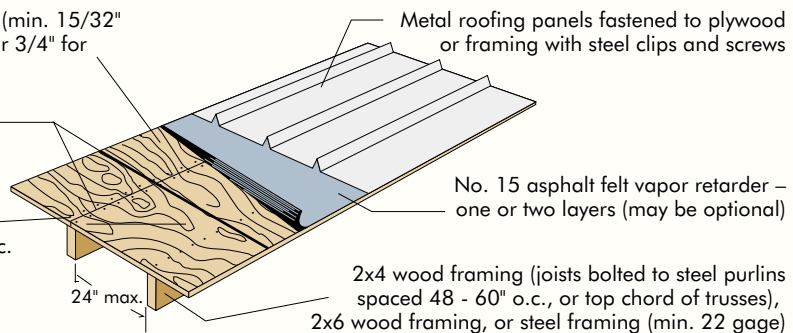

(a) Some rated assemblies and constructions incorporate OSB sheathing and proprietary products. When designing and specifying, check the Underwriters Laboratories (U.L.) Roofing Materials and Systems Directory (Category TGKX) for complete details on a particular assembly in U.L. Construction Nos. 200-500 (series). A change in details may affect the wind uplift classification of the assembly.

(b) See Table 5, page 13, for nail diameter.

Noise Transmission Control

While some attention to sound control may be desirable in certain types of single-family residential buildings, it is mandatory in multifamily, commercial and industrial construction.

Selection of the correct noise-resistant surface and insulation assemblies is based on Sound Transmission Class (STC) and Impact Insulation Class (IIC). The STC rates a structural assembly's ability to reduce airborne noise. Most authorities agree that a multi-occupancy residential floor or wall should have an STC rating of at least 45, while over 50 is considered premium construction. Below 40, loud speech can be audible as a murmur and privacy and comfort are impaired. The level of background noise affects the choice of STC.

The IIC ratings define the capacity to control impact noise and have replaced the earlier Impact Noise Rating (INR). In most cases, required IIC rating values are about the same as for STC.

[Figures 34 and 35](#) show only two of the many sound-resistant floor and wall assemblies that can be obtained with wood structural panels. Some floor-ceiling assemblies also qualify as fire-rated construction.

While many listed assemblies were tested using plywood, other APA OSB and composite structural-use panels may be substituted on a thickness-for-thickness basis. Because of their similar strength and stiffness properties and slightly higher density, use of these products in lieu of plywood will not compromise the STC or IIC ratings of the tested systems.

FIGURE 34

**NOISE-RESISTANT PARTY WALL
STC = 46**

3/8" APA RATED SHEATHING applied vertically with 6d common nails spaced 6" o.c. at edges, 12" o.c. other framing. Nail heads dimpled into panel.

1/2" gypsum wallboard applied vertically, joints staggered. Nail to framing with 8d nails spaced 12" o.c. Joists taped.

2x4 studs spaced 24" o.c. staggered

2x6 plate top and bottom

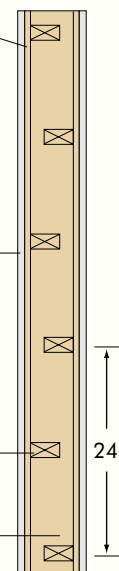

For additional information, see [APA Design/Construction Guide: Noise-Rated Systems, Form W460](#).

Energy Conservation

Insulating Exterior Walls

With adoption of more stringent regulations concerning building insulation, it is increasingly important to build walls to meet new requirements as efficiently as possible. Installation of APA RATED SIDING panels yields tight construction to minimize heat loss due to air infiltration. Framed walls also can be easily insulated to provide U values found in energy standards. [Figure 36](#) illustrates two construction options and their corresponding

FIGURE 35

**NOISE-RESISTANT FLOOR ASSEMBLY^(a)
(Lightweight Concrete Over APA Panels) STC = 58; IIC = 73**

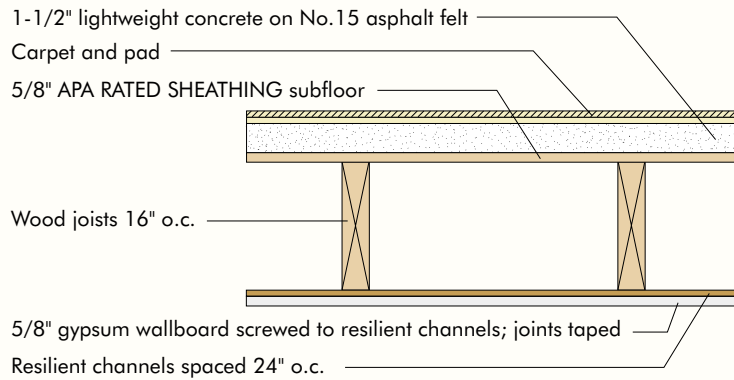

(a) Also meets minimum construction requirements for one-hour fire-rated floor-ceiling assembly per Underwriters Laboratory (U.L.) Design No. L514. Ref. Geiger and Hamme, Inc. tests CCA-10MT and CCA-11MT (1972).

FIGURE 36

ENERGY-CONSERVING STURD-I-WALL ASSEMBLIES

APA RATED SIDING DIRECT TO STUDS

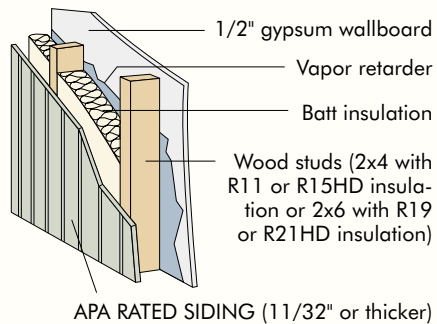

	R
Outside surface (15 mph wind)	0.17
APA RATED SIDING	0.43–0.78
Batt insulation	
Option A – R11	11.00
Option B – R15HD (high density)	15.00
Option C – R19	18.00 ^(a)
Option D – R21HD (high density)	21.00
1/2" gypsum wallboard	0.45
Inside surface (still air)	0.68

Insulation Option	Average U	Minimum Effective R = 1/U
A	0.100	10.01
B	0.086	11.66
C	0.065	15.36
D	0.060	16.70

APA RATED SIDING OVER RIGID FOAM INSULATION SHEATHING

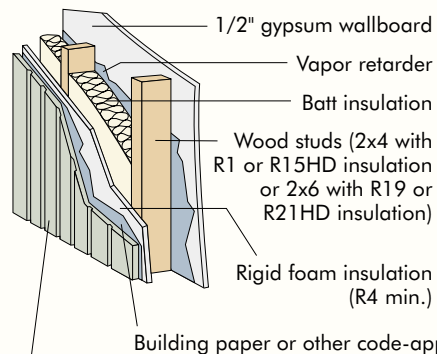

	R
Outside surface (15 mph wind)	0.17
APA RATED SIDING	0.43–0.78
Rigid foam insulation	4.00 (min.)
Batt insulation	
Option A – R11	11.00
Option B – R15HD (high density)	15.00
Option C – R19	18.00 ^(a)
Option D – R21HD (high density)	21.00
1/2" gypsum wallboard	0.45
Inside surface (still air)	0.68

Insulation Option	Average U	Minimum Effective R = 1/U
E	0.070	14.37
F	0.061	16.42
G	0.050	19.87
H	0.047	21.44

APA RATED SIDING (11/32" or thicker). Panel siding meets code requirement for wall bracing.

(a) When compressed to 5-1/2" thickness.
 (b) Average U values include adjustment for 25% framing area with studs spaced 16" o.c. When studs are spaced 24" o.c. (22% framing area), average U values are slightly lower and corresponding R values are higher. Average U value is based on R value at framing of 4.38 for 2x4 wood studs and 6.88 for 2x6 wood studs.

U values. One of the assemblies uses APA RATED SIDING direct to studs, and one shows siding applied over rigid foam insulation. Figure 36 shows the installation of the vapor retarder on the inside of the wall framing for typical construction. Local climatic conditions, energy codes or standard construction practices may vary the actual presence or location of the vapor retarder.

Insulating Panel Roofs

Insulating APA panel roof decks is simpler, quicker and less expensive than other decks since batt insulation can be applied on the underside of the deck when ventilation is provided – and roofing on top – without further preparation. Most metal roof systems, on the other hand, require special rigid insulation on top of the deck to provide the smooth surface needed for roofing. The panel deck with blanket insulation also provides better sound absorption, an important consideration in commercial, industrial and institutional construction.

A wood-frame panel-roof-deck system can be effectively insulated through a variety of techniques. Figure 37 shows four APA panel roof decks – three with insulation and one without. Average U values for below-deck insulation include adjustment for 8 percent framing area.

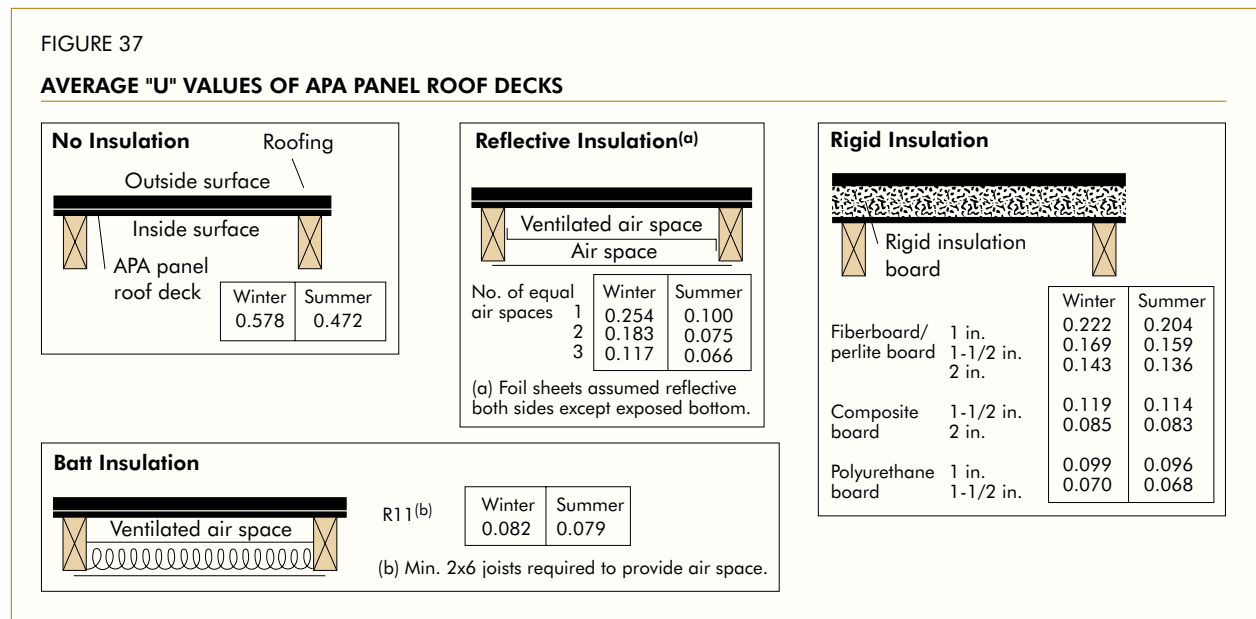

Condensation: Its Cause and Control

Today's construction techniques usually produce a far better sealed and insulated building than those built in the past. At the same time, the modern house is likely to be equipped with appliances that give off moisture. It is more important than ever before, therefore, to provide adequate measures for controlling moisture and condensation. Lack of attention to this area may cause difficulties and costly callbacks.

Studies show that moisture originates both inside and outside the structure. Trouble may start with condensation on the underside of roof decking in the attic. Moisture transmission through walls can cause paint failures on exterior walls. The solution is adequate ventilation and properly placed moisture vapor retarders. Ceiling vapor retarders are typically omitted where attics are well ventilated. Local climatic conditions, energy codes or standard construction practices may make the actual presence or location of the vapor retarder vary.

Minimum ventilation requirements for both attic and crawl space appear in the International Residential Code and in other model building codes. The requirements are based on the ratio of the free ventilation area to the area to be ventilated. The required ratio is 1 to 150, applicable to both crawl spaces and attic areas. When a ground cover is placed in the crawl space, the crawl space ventilation ratio may be reduced to 1 to 1500. The ratio in the attic area may be reduced to 1 to 300 provided: 1) a vapor retarder having a transmission rate not exceeding 1 perm is installed on the warm side of the ceiling, or 2) at least 50 percent of the required ventilating area is provided by ventilators located in the upper portion of the space to be ventilated, with the balance of the required ventilation provided by eave or cornice vents.

In general, condensation can be controlled with a vapor retarder placed on the warm side of the walls and below concrete slabs or as a ground cover in crawl spaces, along with adequate ventilation in attics and crawl spaces.

Ventilation should not be cut off at any time during the year when it is the only means of moisture control in crawl spaces. In cold climates, low temperatures beneath the first floor may be expected in a ventilated crawl space, and insulation will be required in the floor and around exposed mechanical lines. When a vapor retarder is installed for ground cover, vents may be closable and the perimeter foundation wall may be insulated in lieu of the floor.

Additional information concerning controlling mold and mildew may be found in [APA's Build A Better Home: Mold And Mildew, Form A525](#).

Moisture control recommendations for low slope APA panel roof decks are described in [Engineered Wood Systems \(EWS\) Technical Note, Moisture Control in Low Slope Roofs, Form EWS R525](#), available from APA.

Additional information is available in [Engineered Wood Systems \(EWS\) Technical Note, Controlling Decay in Wood Construction, Form EWS R495](#) and [APA's Build A Better Home: Roofs, Form A535](#).

Thermal Resistance of Wood Structural Panels

For most wood structural panel applications, the most important thermal quality is resistance, or insulating effectiveness. While wood structural panels include plywood and OSB and can be made up of a number of different species, the thermal resistance property is relatively insensitive to such differences. For determining the overall coefficient of heat transmission (U), as illustrated above, APA publications rely on the thermal resistance values for softwood published by the American Society of Heating, Refrigeration and Air Conditioning Engineers (ASHRAE). Use of this single value simplifies computations and produces only insignificant differences in resulting design heat losses. [Table 38](#) shows thermal resistance, R, for several panel thicknesses.

TABLE 38

THERMAL RESISTANCE

Panel Thickness (in.)	Thermal Resistance, R ^(a)
1/4	0.31
5/16	0.39
3/8	0.47
7/16	0.55
15/32	0.59
1/2	0.62
19/32	0.74
5/8	0.78
23/32	0.90
3/4	0.94
7/8	1.09
1	1.25
1-1/8	1.41

(a) Degree F-hr.-sq.ft./BTU

RELATED PANEL SYSTEMS

The Permanent Wood Foundation

The Permanent Wood Foundation (PWF), also referred to as the All-Weather Wood Foundation (AWWF), is made up of pressure-preservative-treated below-grade stud walls built of lumber and APA trademarked plywood. The system is accepted for FHA mortgage insurance programs. It's accepted by the major model building codes and most state and local codes. And, whether full basement or crawl space, the PWF is adaptable to almost any site and light-frame building design.

For complete design and construction recommendations, contact the American Forest & Paper Association, 1111 19th Street, NW, Suite 800, Washington, DC 20036; or the Southern Pine Council, P.O. Box 641700, Kenner, Louisiana 70064.

Plywood for Outdoor Decks

Exterior-type plywood may be used in outdoor deck applications. Recommended grades include APA RATED STURD-I-FLOOR Exterior, C-C Plugged, Underlayment C-C Plugged, or Marine. Where the deck may be exposed to long-term dampness, such as applications where the plywood is topped with outdoor carpet, the plywood should be pressure-treated with a waterborne ACQ or copper azole preservative in accordance with AWWPA Standards for above-ground exposure. For optimum performance, slope the deck away from the structure. A slope of 1/4 to 1/2 inch is suggested.

Space panels 1/8 inch at ends and edges to allow for expansion. Caulk the joints to prevent water leakage into areas underneath. To avoid fastener corrosion, use hot-dip or hot-tumbled galvanized nails. If the underside of the joists is covered, the floor-ceiling cavity should be vented to aid in drying and to prevent potential moisture buildup in the deck.

If there is a dry living area underneath the deck, apply a membrane roof covering or high performance coating over the surface. The coating should be able to accommodate normal dimensional changes in the plywood without rupturing or cracking. Under these conditions, APA RATED STURD-I-FLOOR Exposure 1 may be used unless otherwise recommended by the coating manufacturer, and preservative treatment of the panels is not necessary.

Plywood for Concrete Forming

Plywood is an ideal material for concrete forming. It produces smooth concrete surfaces and can be used repeatedly – some overlaid panels up to 200 times or more. The thinner panels can be bent easily for curved forms and liners. Plywood's excellent stiffness minimizes deflection during pouring. Its natural insulating qualities help provide more consistent curing conditions. The large panel size and light weight reduce form construction and stripping time. And various surface textures are available for imparting attractive and unusual concrete textures.

Although nearly any Exterior plywood can be used for concrete forming, a special panel called PLYFORM® Class I is manufactured specifically for the purpose. PLYFORM also can be manufactured with a High Density Overlay (HDO) surface, and in Structural I panels. HDO PLYFORM has an exceptionally hard surface for the smoothest possible concrete finishes and maximum number of pours. Structural I PLYFORM is stronger and stiffer than PLYFORM Class I, particularly in the cross-panel direction, and is sometimes used for high pressures where long dimension is parallel to supports. Additional plywood grades designed for concrete forming include special overlays and proprietary panels.

For complete design information, write for [APA's Design/Construction Guide: Concrete Forming, Form V345](#).

Structural Insulated Panels

The structural insulated panel (SIP) offers the stiffness and load handling capability of a stressed-skin panel, plus light weight, high insulation values for relatively small thicknesses, and fast panelized construction. Panels are prefabricated by sandwiching an insulating core material such as polystyrene or polyurethane foam, or a paper honeycomb, between wood structural panel “skins.” A structural bond is formed between the core and the skins with full structural glues or, in the case of some foam materials, by direct adhesion of foam to the skins.

With APA panel siding for the outside skin, structural insulated panels make attractive, energy-conserving walls on both residential and commercial buildings. A typical structural insulated floor panel might have 19/32-inch top skin and 3/8-inch bottom skin. Check local building requirements relating to thermal barrier protection of plastic foam. For additional information, refer to [APA Product Guide, Structural Insulated Panels, Form W605](#), or contact the Structural Insulated Panel Association (SIPA) at their web site: www.sips.org.

APA Panels Over Metal Framing

Modern fastening methods are rapidly expanding the use of APA panels over metal framing. Self-drilling, self-tapping fasteners commonly are used to attach panels up to 1-1/8 inch thick to steel flanges. Panels also can be fastened to lighter members, such as formed steel joists, with special hardened screw-shank nails. Construction adhesives are recommended with hardened screw-shank nails. Consult metal-framing manufacturers for recommended adhesives. Since threads usually extend only part way up the shank of self-drilling, self-tapping screws and screw-shank nails, it is important to specify a length sufficient to engage the metal framing.

Typical panel-to-metal framing systems are illustrated in [Figure 38](#). Load-span recommendations are the same as for wood-frame systems. For more information, write for [APA Design/ Construction Guide: Wood Structural Panels Over Metal Framing, Form T625](#).

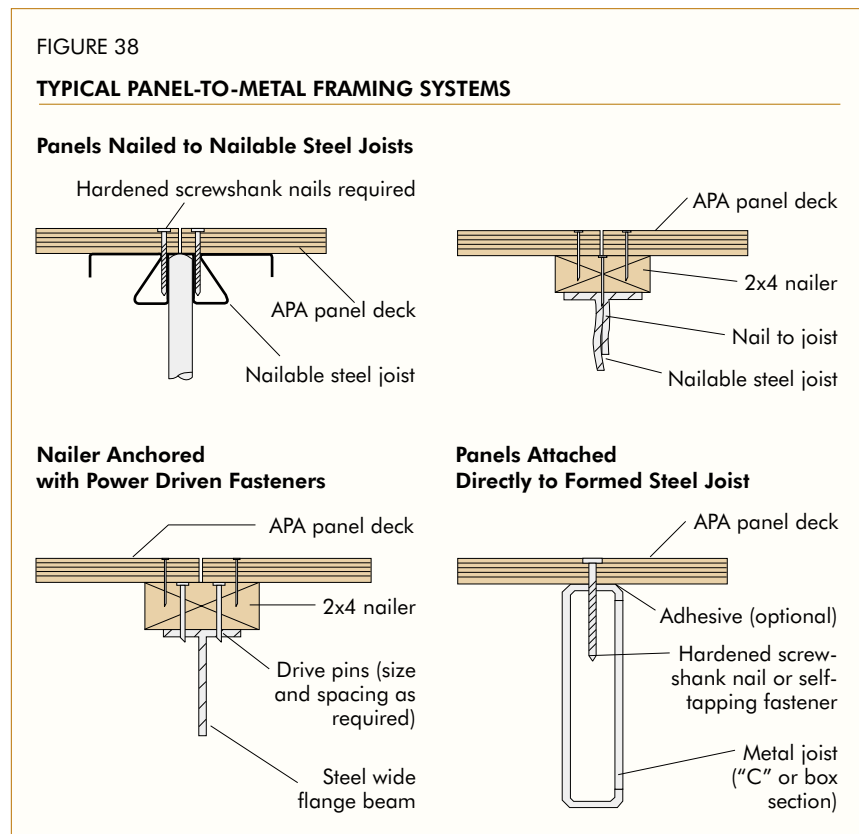

APA Panel Systems Over Concrete Slabs

A system of APA panels over sleepers embedded in mastic has been successfully installed over concrete slabs. Tongue-and-groove panels eliminate the need for blocking between sleepers at panel edges and allow air circulation beneath the floor. Use only panels marked Exterior or Exposure 1. A vapor barrier is essential directly above or below the slab. Preservative treatment of the sleepers is recommended when the slab is on or below grade, although panels normally will not require treatment.

Tongue-and-groove plywood can be installed over polystyrene or polyurethane foam. The foam, bonded to both the plywood and concrete slab with mastic, provides high insulating value and resistance to termites, rot and fungus. Exterior plywood at least 15/32 inch thick is recommended. A vapor barrier such as polyethylene is required either directly above or below the concrete slab.

Special Floor Surfacing

Hardboard overlaid plywood (APA PLYRON®) is sometimes used as a finish floor, especially for industrial installation. (Check your local dealer for availability.) High Density Overlay (HDO) panels with a special heavy-duty screen-grid surface provide skid-resistant, long-wearing surfaces under foot traffic. And a number of liquid coatings – some suitable for balconies, porches, patio decks and other exterior applications – are also available.

ADDITIONAL INFORMATION

About APA – The Engineered Wood Association and Engineered Wood Systems

APA – The Engineered Wood Association is a nonprofit trade association of and for structural wood panel, glulam timber, wood I-joist, laminated veneer lumber, and other engineered wood product manufacturers. Based in Tacoma, Washington, APA represents approximately 150 mills throughout North America, ranging from small, independently owned and operated companies to large integrated corporations.

Always insist on engineered wood products bearing the **mark of quality** – the APA or APA EWS trademark. Your APA engineered wood purchase is not only your highest possible assurance of product quality, but an investment in the many trade services that APA provides on your behalf. The Association’s trademark appears only on products manufactured by member mills and is the manufacturer’s assurance that the product conforms to the standard shown on the trademark.

For panels, that standard may be an APA performance standard, the Voluntary Product Standard PS 1-95 for Construction and Industrial Plywood or Voluntary Product Standard PS 2-04, Performance Standards for Wood-Based Structural-Use Panels. Panel quality of all APA trademarked products is subject to verification through APA audit.



The APA EWS trademark appears only on engineered wood products manufactured by members of Engineered Wood Systems, a division of APA. The mark signifies that the manufacturer is committed to a rigorous program of quality verification and testing and that products are manufactured in conformance with an APA or national standard such as ANSI Standard A190.1, American National Standard for Structural Glued Laminated Timber or with a manufacturer’s building code evaluation report.

APA’s services go far beyond quality testing and inspection. Research and promotion programs play important roles in developing and improving plywood and other panel construction systems, and in helping users and specifiers to better understand and apply engineered wood products. For more information, please see the back cover.

In 1905, a small wooden box company produced the first softwood plywood. Displayed that year at the World’s Fair in Portland, Oregon, the Douglas-fir “3-ply veneer work” soon caught attention and became a thriving national and international industry. APA, which was founded in 1933 as the Douglas Fir Plywood Association, is celebrating the plywood centennial in 2005. For more information, please visit www.apawood.org/plywoodcentennial.

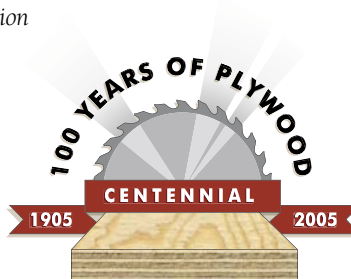



ENGINEERED WOOD CONSTRUCTION GUIDE

APA offers a comprehensive set of services and tools for design and construction professionals specifying and using engineered wood products and building systems. If you're looking for detailed product information, training material, or technical assistance, APA can help.

- ▶▶▶ www.apawood.org, APA's web site, is your link to in-depth design and building support, including a library of more than 400 publications available for instant pdf download or hard-copy purchase.
- ▶▶▶ help@apawood.org or (253) 620-7400 is your connection to the APA Product Support Help Desk. Staffed by specialists who have the knowledge to address a diverse range of inquiries related to engineered wood, the Help Desk can answer your questions about specification and application of APA products.

Tap into APA's extensive knowledge and resources.

- Training materials and assistance, including Wood University, APA's online portal for engineered wood education, located at www.wooduniversity.org
- Information to protect homes against damaging moisture infiltration through the Build a Better Home and Free From Mold programs, including guides and details for builders at www.buildabetterhome.org and an inspection regimen for homeowners at www.freefrommold.org
- More than 100 downloadable CAD details, found at www.apacad.org
- Field representatives in many major U.S. cities and Canada who can answer questions about APA trademarked products

For a list of APA and APA EWS publications, request or download the *APA Publications Index*, Form B300, or the *EWS Publications Index*, Form S400, at www.apawood.org/publications.

APA – THE ENGINEERED WOOD ASSOCIATION HEADQUARTERS
7011 So. 19th St. Tacoma, Washington 98466 ■ (253) 565-6600 ■ Fax: (253) 565-7265

DISCLAIMER

The information contained herein is based on APA – The Engineered Wood Association's continuing programs of laboratory testing, product research, and comprehensive field experience. Neither APA, nor its members make any warranty, expressed or implied, or assume any legal liability or responsibility for the use, application of, and/or reference to opinions, findings, conclusions, or recommendations included in this publication. Consult your local jurisdiction or design professional to assure compliance with code, construction, and performance requirements. Because APA has no control over quality of workmanship or the conditions under which engineered wood products are used, it cannot accept responsibility of product performance or designs as actually constructed.

Form No. E30T/Revised March 2005/0800

