

Novel Application of Magneto-resistive Sensors for High-Voltage Transmission-Line Monitoring

X. Sun¹, K. S. Lui¹, K. K. Y. Wong¹, W. K. Lee¹, Y. Hou¹, Q. Huang², and P. W. T. Pong¹

¹Department of Electrical and Electronic Engineering, The University of Hong Kong, Hong Kong

²School of Automation Engineering, University of Electronic Science and Technology of China, Chengdu 61173, China

High-voltage transmission lines are responsible for transmission of electric power. Their sag and electric current are important parameters for transmission-line monitoring. In this paper, a simple and promising method based on magneto-resistive sensors is proposed for transmission-line monitoring. This is a noncontact method and its installation is simple without the need for power cut. The method involves measuring emanated magnetic field from a line conductor at the ground level and, then, calculating the source position and current inversely. A proof-of-concept laboratory setup was constructed and a series of experiments were carried out for demonstration. This method can handle complicated transmission-line configuration by integrating the stochastic optimization approach into the inverse electromagnetic calculation. It was tested with the computational simulation of a 500 kV transmission-line configuration. The result shows the feasibility of using this transmission-line monitoring method in reality.

Index Terms—Galloping, magneto-resistive (MR) sensors, overhead transmission lines, sagging, smart grid.

I. INTRODUCTION

LONG-DISTANCE high-voltage power transmission is vital in electricity power delivery because power loads are usually far away from power generation sites. Overhead transmission lines are reliable power carriers, which provide the competent ability for the present power grids to transfer electricity from sources to distribution networks and, then, to the consumers. In view of its instantaneous nature, electricity is generated and used and cannot be stored in large scale at present. During the transmission process of electricity, balance must be constantly maintained to match the power supply and demand. Especially when an on-peak demand is coming, power companies have to supply excessive amount of electricity within the rating limits of transmission lines. Thus, transmission-line monitoring is a very important issue to ensure effective and reliable transmission of electricity.

Electric current and line positions are two important parameters to measure for transmission lines. The electric current flowing in the lines should be measured to avoid/reduce overload, phase unbalance, fluctuation, etc. Line positions should be monitored to keep track of the sagging and galloping situations. Conductors between two transmission towers often suffer sagging and galloping. Sagging is the length extension of a line conductor caused by overheating due to excessive current loading. Sagging can lower a conductor to an unsafe height above the earth. Galloping is the low-frequency, large-amplitude, wind-induced oscillation of overhead transmission lines [1]. The oscillations can cause serious transmission problems, such as flashover due to infringed line-to-line clearances, risk of mechanical failure of transmission tower, and excessive loading stress. Finally, if a power utility can accurately measure both electric current and line positions in real time, the resulting knowledge will enable the dynamic rating

of the power networks. Hence, transmission-line monitoring is critical for the efficient usage of power line capacity and reliable operation of power transmission networks. Advanced sensor technology is needed to fulfill these requirements for transmission-line monitoring in the smart grid, which will modernize our present power grids and enable the wide-scale utilization of renewable energy [2].

At present, there are several techniques and devices for transmission-line monitoring. Current transformers (CTs) are typically used for current measurement. However, they are expensive and limited by their magnetic core characteristic and narrow bandwidth [3], [4]. There are some existing devices that can directly or indirectly measure sag of transmission lines. “Power donut” is a temperature sensor platform installed on live wires [5]. However, this device measures the conductor surface temperature rather than the core temperature for calculating sag. In addition, it is an expensive platform and its installation requires working with live wires. Another device is a tension sensor that calculates the sag from the measured tension on a transmission line [6]. However, it requires expensive equipment and complicated installation. A promising technology using the global positioning system (GPS) is under development [7]. This technology is still in its infancy. Problems such as installation, shielding, and electromagnetic interference (EMI) from phase conductors have to be confronted. In another technique, camera and image-processing technology are used to measure conductor sag [8]. It is a costly technique and its installation requires contact with phase conductors for placing the targets. A method based on electromagnetic coupling was reported for transmission-line monitoring [9]. However, for different line configurations, the grounded wire position and the sag calculation need to be modified. Also, EMI from nearby transmission lines cannot be neglected.

The new method proposed here makes innovative use of magneto-resistive (MR) sensors, and it is competent for transmission-line monitoring and addresses the problems and limitations of the other techniques and devices [10]. The MR sensors can be installed on the ground level so that power outage is avoided and there is no need to work with live wires. It calculates the current

Manuscript received February 21, 2011; revised May 04, 2011; accepted May 20, 2011. Date of current version September 23, 2011. Corresponding author: P. W. T. Pong (e-mail: ppong@eee.hku.hk).

Color versions of one or more of the figures in this paper are available online at <http://ieeexplore.ieee.org>.

Digital Object Identifier 10.1109/TMAG.2011.2158085

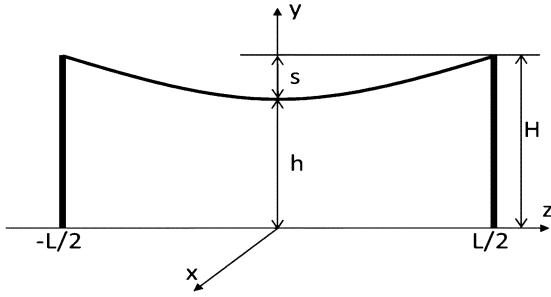

Fig. 1. Conductor sag of a transmission line.

flow and line positions from the magnetic field emanated from the phase conductors.

II. METHOD AND TECHNOLOGY

The magnetic field generated by a single-phase conductor element can be described by using the Biot–Savart law

$$\mathbf{B} = \int \frac{\mu_0 I d\mathbf{w} \times \mathbf{r}}{4\pi |\mathbf{r}|^3} \quad (1)$$

where

- I source current;
- $d\mathbf{w}$ vector whose magnitude is the length of the differential element of source at the direction of the current;
- \mathbf{r} displacement vector from the source element to the point where magnetic field is being computed;
- μ_0 permeability of free space;
- \mathbf{B} net magnetic field.

In case of multiple-phase conductors, the resulting magnetic field can be determined by applying the superposition principle. It should be observed that in (1), the resulting magnetic flux density at the field point carries the electric and spatial information of the current source. If magnetic field data are collected at some points within span, electric current flow and line positions can be calculated by solving an inverse problem of electromagnetism (EM) [11]. Overhead line conductors suspended between towers take on the appearance of catenary due to their own weights. The conductor sag can be calculated using the parameters shown in Fig. 1: H is the height of the suspension points on the towers, L is the span distance, s is the conductor sag, and h is the height of the lowest point along the conductor. The conductor catenary that is symmetric with the y -axis and placed in the y - z plane can be described by

$$y = a \cosh\left(\frac{z}{a}\right) + y_0. \quad (2)$$

The parameters a and y_0 are determined by the origin of the catenary coordinate system as discussed in [12]. The differential element of conductor catenary can be written as

$$d\mathbf{w} = \sinh\left(\frac{z}{a}\right) dz \mathbf{a}_y + dz \mathbf{a}_z. \quad (3)$$

By applying the Biot–Savart law, the magnetic field generated by phase current flowing in the line conductor can be determined at any point in vicinity [10]. In order to illustrate how the emanated magnetic field provides detailed information of line conductors, a practical 500 kV transmission-line configuration was simulated

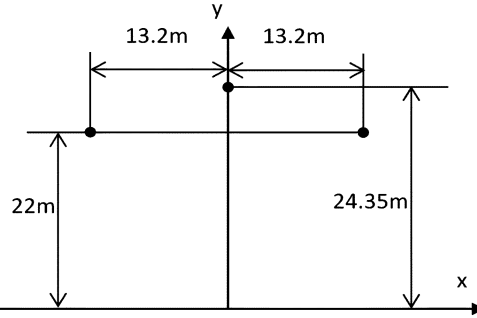

Fig. 2. Conductor configuration of 500 kV transmission lines (three-phase conductor lines are denoted by solid circles).

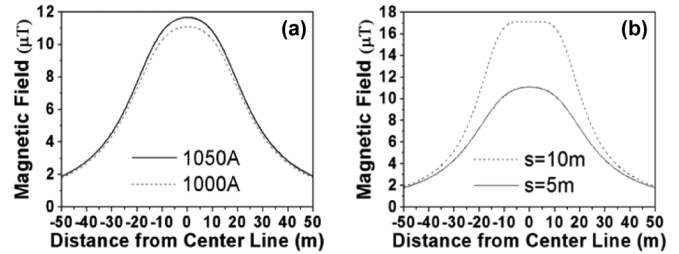

Fig. 3. Magnetic field emanated from a 500 kV transmission line at the midspan (a) simulated with different currents and (b) simulated with different sags.

with increasing current load and various sags. The line configuration shown in Fig. 2 has a span of 400 m and the current per phase is 1000 A. Fig. 3(a) shows the magnetic field generated at the midspan along the x -axis at the height of 1 m from the ground. The lateral profile of the magnetic field was simulated with different phase currents of 1000 A and 1050 A with the same sag of $s = 5$ m. Fig. 3(b) shows the same simulation but using different sag values ($s = 5$ m and $s = 10$ m) with the same phase current of 1000 A. The simulation results show that the changes in electric current or sag are reflected by the magnetic field emanated from the lines. Similarly, this technology is also applicable for galloping. Provided the sensitivity of the magnetic sensors is sufficient, the electric and spatial information of the overhead line can be found by inverse calculation from the magnetic field measured at the ground level. According to the simulation results in Fig. 3, the strength of the magnetic field emanated from an overhead line is typically on the order of 10^{-5} T. Currently, commercially available anisotropic magnetoresistance (AMR), giant magnetoresistance (GMR), and tunneling magnetoresistance (TMR) sensors can provide sensitivity of around 10^{-7} , 10^{-8} , and 10^{-9} T, respectively. Therefore, the sensitivities of MR sensors are two to four orders of magnitude larger than necessary to carry out the monitoring in this novel application.

III. EXPERIMENT

In order to verify this transmission-line monitoring technology, a scaled laboratory setup including a set of sensors and an electric power line was established in the Smart Grid and High Power System Laboratory, The University of Hong Kong, Hong Kong, to act as the test bed for transmission-line monitoring. The setup is shown in Fig. 4. It consists of two MR sensors, an infrared (IR) sensor, an electric power cable, and two suspension towers. The MR sensors act as core components, which are used to measure magnetic-field vectors with high

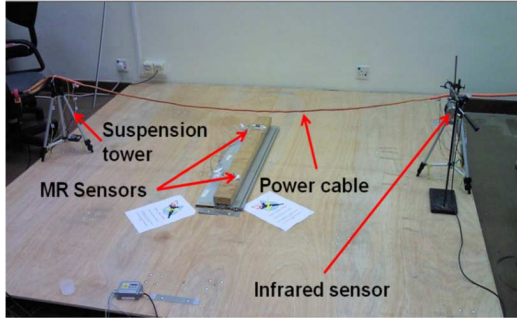

Fig. 4. Scaled laboratory setup of transmission-line monitoring.

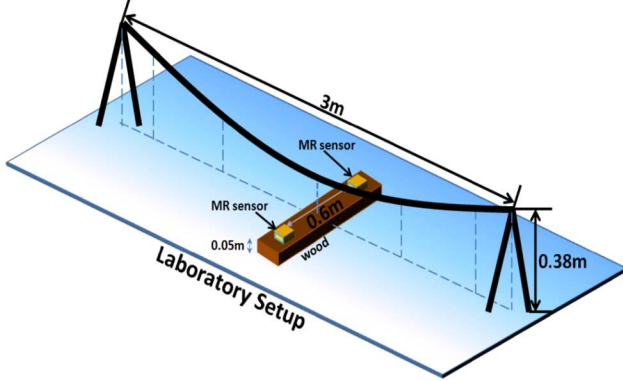

Fig. 5. Schematic diagram of the laboratory setup. A piece of wood was used to mount the MR sensors. The dashed lines are imaginary lines illustrating the relative positions and orientations of the MR sensors.

sensitivity. The vectors data are important inputs for calculating electric current and spatial information of the line conductor. Honeywell HMC2003 three-axis AMR sensor hybrid was selected. It can handle the measurements of magnetic-field vectors in three orthogonal coordinate axes simultaneously. The IR sensor is a fast-response and high-accuracy temperature sensor. It is used to monitor the cable from overheating. The heights of the suspension towers can be adjusted to control the altitude of the cable. Fig. 5 shows the schematic diagram of this laboratory setup. The height of the suspension towers is 0.38 m. The distance between the towers is 3 m. The two MR sensors are placed symmetrically at the midspan along the x -axis at the height of 5 cm. The distance between them is 0.6 m. The lowest point along the power cable was moved to different positions in order to simulate various sagging and galloping situations. The magnitude of the electric current was 150 A (rms) and its frequency was 50 Hz. The electric current was monitored with a Fluke 434 power quality analyzer. The measurement results of the magnetic flux density vectors are displayed in Table I.

Given a current source element, construct a line perpendicular to the generated magnetic flux density vector at the field point and therewith the line must pass through the source element. By the same token, with the magnetic flux density vectors measured at two field points, the position of their common source can be determined. The cross points of the two constructed perpendicular lines are determined to be the position of the common source. Fig. 6 shows the locations of the calculated and the actual source positions for the cases of Table I. From Cases 1 and 2, we can see that as the height of the cable was lowered from 38 to 35 cm, the MR sensors detected such descending movement, and thus, they could successfully trace the sagging of the cable with the error less than 2 cm. From Cases 3 and 4, we

TABLE I
LOWEST POINT OF CABLE AND MEASURED MAGNETIC-FIELD VECTOR

	Sag (x, y)	Sensor 1		Sensor 2	
		B_x (10^{-5} T)	B_y (10^{-5} T)	B_x (10^{-5} T)	B_y (10^{-5} T)
1	(0, 38)	2.816	-3.852	3.074	3.999
2	(0, 35)	2.968	-4.227	3.224	4.432
3	(8, 30)	2.408	-4.668	4.152	3.761
4	(-8, 30)	4.812	-3.211	2.168	4.103

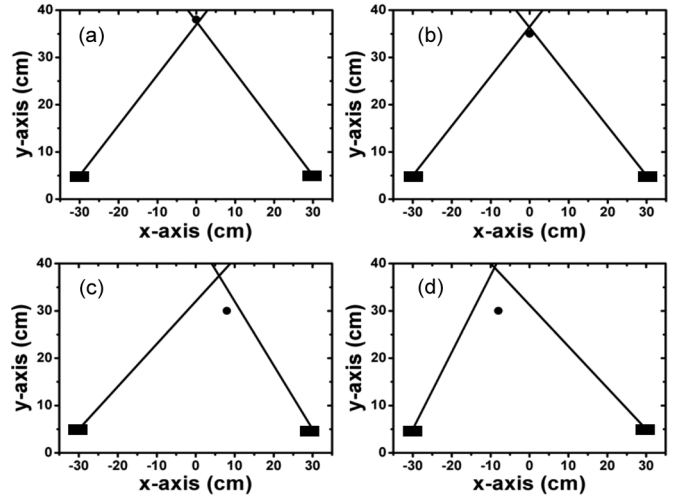

Fig. 6. Measured power cable position and actual position. (a)–(d) Cases 1–4 given in Table I, respectively. The black dot denotes the actual position of the cable and the black rectangles denote the MR sensor positions.

can see that as the cable position was moved from right (+8 cm) to left (−8 cm), again the MR sensors detected such lateral movement, and thus, they could successfully trace the galloping of the cable. These results were obtained only with two MR sensors and without any accessory components, such as flux concentrators or magnetic shieldings. The error will be reduced significantly if group of data from an MR sensor array is used and statistical results can be obtained. With the knowledge of the source position and its resulting magnetic field, the source current can be calculated easily. The solution of the current can be calculated from the measured magnetic field \mathbf{B} by

$$\mathbf{I} = (\mathbf{A}^T \mathbf{A})^{-1} \mathbf{A}^T \mathbf{B} \quad (4)$$

where \mathbf{A} is the coefficient matrix that depends on the source configuration. The magnitude of the current was determined to be 148.7 A for Case 1 and 156.9 A for Case 2. The error is less than 5%. In addition, from the time-domain waveform of the magnetic field measured by the MR sensors, the frequency spectrum of the electric current was obtained by the Fourier transform. As expected, the frequency spectrum (see Fig. 7) exhibits a peak at 50 Hz, which is the frequency of the electric current.

IV. DISCUSSION

As demonstrated with this proof-of-concept laboratory setup, the proposed method can realize simple power line monitoring on both electric current and line position. There are differences between laboratory condition and actual operating environment. In real situations, we need to consider more factors, such as image current due to a conducting ground, multiple power cables, double circuits, and bundled phase conductors. Further development and optimization of the method are needed to cope

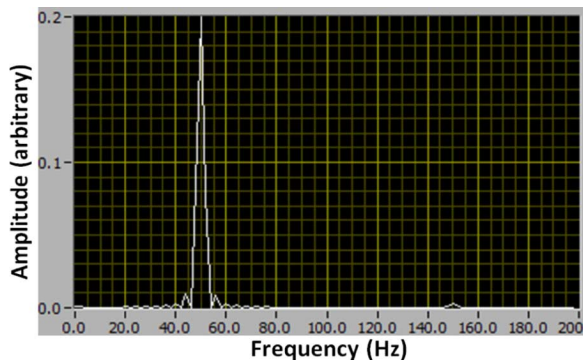

Fig. 7. Frequency spectrum of the electric current obtained from the time-domain waveform of the magnetic field measured by the MR sensors.

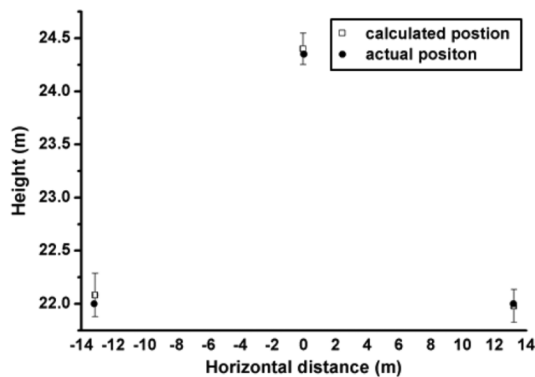

Fig. 8. Calculated conductor positions with standard deviations by the AIS technique.

with these complicated scenarios. The aforementioned simple analytical method with only two MR sensors will have difficulty in handling these complicated situations. In these cases, one may want to use an array of MR sensors for measurement and treat the whole issue as an inverse problem of EM, and then, to solve the inverse problem by using the stochastic optimization technique [13]. The stochastic optimization technique was inspired by the biological process of immunity and it is called the artificial immunity system (AIS) [14]. The optimal transmission-line configuration and current flow are determined by reconstructing magnetic field at a series of field points stochastically and minimizing the Euclidean distance between the calculated and the measured magnetic fields. The method is put into practice for calculation in the computational simulation of the three-phase transmission-line configuration shown in Fig. 2. The effect of image current is considered in both the computational simulation and the stochastic optimization process. Fig. 8 shows the identification of conductor positions with this stochastic approach. The calculated line positions are very close to the actual positions with an average error of only 6 cm or 0.246% in terms of percentage. It is evident that this technique can provide an accurate identification for transmission-line positions. Furthermore, this AIS technique can also handle conductor line sagging and galloping. As such, the proposed transmission-line monitoring method with MR sensors can be extended to more complicated line configurations by integrating the AIS technique into the inverse calculation problem. This inverse calculation algorithm was coded in MATLAB and run on a normal desktop computer. It just takes a few minutes to solve the inverse problems. The

computational time can be further suppressed by coding in C language and optimizing the code. This greatly facilitates real-time monitoring on sagging and galloping.

V. CONCLUSION

A widely applicable, low-cost, noncontact, and accurate method for transmission-line monitoring was proposed and demonstrated in this paper. This method measures the emanated magnetic field from the transmission line to determine the phase conductor current and line position. The proof-of-concept experiments on a single power cable showed that this technique is feasible and practical. An inverse calculation method based on stochastic optimization (AIS) was applied for solving more complicated scenarios with multiple transmission lines. The AIS optimization can enable this transmission-line monitoring technique to handle various line configurations. As such, this monitoring technology has great potential to enhance situational awareness, enable dynamic line rating, optimize asset utilization, and realize advanced system measurement of the future smart grid.

ACKNOWLEDGMENT

This work was supported by the Seed Funding Program for Applied Research and the Initiative on Clean Energy and Environment of The University of Hong Kong.

REFERENCES

- [1] S. W. Rienstra, "Nonlinear free vibration of coupled spans of overhead transmission lines," in *Proc. 3rd Eur. Conf. Math. Ind.*, 1988, pp. 133–144.
- [2] S. M. Amin and B. F. Wollenberg, "Toward a smart grid: Power delivery for the 21st century," *IEEE Power Energy Mag.*, vol. 3, no. 5, pp. 34–41, Sep. 2005.
- [3] A. Cataliotti *et al.*, "Characterization of current transformers in the presence of harmonic distortion," presented at the presented at IEEE Int. Instrum. Meas. Technol. Conf., Victoria, Vancouver Island, Canada, 2008.
- [4] A. Cataliotti *et al.*, "Frequency response of measurement current transformers," presented at the presented at IEEE Int. Instrum. Meas. Technol. Conf., Victoria, Vancouver Island, Canada, 2008.
- [5] L. Fish, *Low Cost Sensors for Real Time Monitoring of Overhead Transmission Lines*. Washington, DC: Underground Systems Inc., 2006.
- [6] February 5, 2010, Tension Monitor [Online]. Available: <http://www.cat-1.com>
- [7] C. Mensah-Bonsu *et al.*, "Application of the global positioning system to the measurement of overhead power transmission conductor sag," *IEEE Trans. Power Del.*, vol. 17, no. 1, pp. 273–278, Jan. 2002.
- [8] Transmission Enhancement Technology Report Western Area Power Administration Denver CO 2002.
- [9] R. G. Olsen and K. S. Edwards, "A new method for real-time monitoring of high-voltage transmission-line conductor sag," *IEEE Trans. Power Del.*, vol. 17, no. 4, pp. 1142–1152, Oct. 2002.
- [10] A. Edelstein, "Advances in magnetometry," *J. Phys., Cond. Matter*, vol. 19, pp. 165217–, Apr. 2007.
- [11] P. Neittaanmaki *et al.*, *Inverse Problems and Optimal Design in Electricity and Magnetism*. New York: Oxford Univ. Press, 1996.
- [12] A. V. Mamishev *et al.*, "Effects of conductor sag on spatial distribution of power line magnetic field," *IEEE Trans. Power Del.*, vol. 11, no. 3, pp. 1571–1576, Jul. 1996.
- [13] A. Canova *et al.*, "Identification of an equivalent-source system for magnetic stray field evaluation," *IEEE Trans. Power Del.*, vol. 24, no. 3, pp. 1352–1358, Jul 2009.
- [14] F. Freschi and M. Repetto, "Comparison of artificial immune systems and genetic algorithms in electrical engineering optimization," *Int. J. Comput. Math. Electr. Electron. Eng.*, vol. 25, pp. 792–811, 2006.